



# 2025 Design Standards

## INDEX

A	Substructure
B	Shell
C	Interiors
D	Services
E	Equipment and Furnishings
G	Sitework
Sustainability & Space Programming Requirements	
Door Hardware Standards	

# 2025 Design Standard Section Leaders

Discipline / Section	Level 2	Level 3	FM Section Leader	Email	
A - Substructure			Andrew Spurlin	jas0250@auburn.edu	
B - Shell			Mary Melissa Taddeo	mmy0001@auburn.edu	
C-Interiors	C10 - Interior Construction		Mary Melissa Taddeo	mmy0001@auburn.edu	
	C20 - Stairs		Sarah Rakestraw	gregosa@auburn.edu	
	C30 - Interior Finishes				
D - Services	D10 - Conveying		Scott McClure	mccluws@auburn.edu	
	D20 - Plumbing				
	D30 - HVAC	D3010 - Energy Supply		Rob Engle	englerc@auburn.edu
		D3020 - Heat Generation Systems		Bob Hix	hixjame@auburn.edu
		D3030 - Cooling Generating Systems			
		D3040 - Distribution Systems			
		D3060 - Controls and Instrumentation		Scott McClure	mccluws@auburn.edu
	D3070 - Systems Testing and Balancing		Bob Hix	hixjame@auburn.edu	
	D40 - Fire Protection		Nolan Yon	yonbenj@auburn.edu	
D50 - Electrical		Matt Wagner	mhw0007@auburn.edu		
E - Equipment and Furnishings	E10 - Equipment		Sarah Rakestraw	gregosa@auburn.edu	
G - Building Sitework	G10 - Site Preparation		Ben Burmester	burmebc@auburn.edu	
	G20 - Site Improvements				
	G30 - Site Mechanical Utilities	G3010 - Water Supply		Rob Engle	englerc@auburn.edu
		G3020 - Sanitary Sewer		Ben Burmester	burmebc@auburn.edu
		G3030 - Storm Sewer			
		G3040 - Heating Distribution			
		G3050 - Cooling Distribution		Rob Engle	englerc@auburn.edu
	G3060 - Fuel Distribution				
	G40 - Site Electrical Utilities			Matt Wagner	mhw0007@auburn.edu
Sustainability & Space Programming Requirements	Sustainability	Sustainable Building Standards	Brad Prater	bap0036@auburn.edu	
	Space Programming Requirements	Attic Space		Scott McClure	mccluws@auburn.edu
		"Attic Stock" Storage Room		Dee Snead	deesneed@auburn.edu
		Custodial Closets		Mary Melissa Taddeo	mmy0001@auburn.edu
		Single Toilet Room			
		Shower			
		Lactation Room		Scott McClure	mccluws@auburn.edu
		Mechanical Rooms and Electrical Rooms		Brad Carnett	gamecb@auburn.edu
		Telecom Rooms & Systems		Mary Melissa Taddeo	mmy0001@auburn.edu
		Stairways		Bruce Arnold	gba0004@auburn.edu
Security/Electronic Access Control System (EACS) Rooms		Michael Adams	mma0013@auburn.edu		
Facility Security					
Door Hardware Standards	Door Hardware Standards		Bruce Arnold	gba0004@auburn.edu	
Signage Standards			Davis Pemberton	dgp0009@auburn.edu	
Campus Master Plan Alignment and Space Standards			Judd Langham	langhjm@auburn.edu	
Landscape Master Plan					



## 2025 Section A – Substructure

### INDEX

A10	Foundations
A20	Basement Construction
Document Revision History	

## **A Substructure**

### **A. General**

1. The minimum standard concrete mix shall be 3,000 psi.
2. Calcium chloride or admixtures containing chlorides shall not be used.
3. An approved air-entraining admixture shall be used for all concrete exposed to weather. When used, the concrete must be tested at the site immediately prior to placement to verify the proper amount of air-entrainment is present.
4. Aluminum (or any other material that is not compatible) conduits and pipes shall not be embedded in any concrete.
5. Reinforcing coverage in concrete must meet the requirements of the most current version of American Concrete Institute (ACI) 318.

### **A10 Foundations**

#### **A1020 Special Foundations**

##### **A1021 Pile Foundations**

- A. Driven pilings or rammed aggregate foundations are not to be used without prior approval.

#### **A1030 Slab on Grade**

##### **A. General**

1. Control joints, isolation joints, and construction joints shall be designed, located, and otherwise clearly defined by the Designer of Record.
2. Control joints shall be fully coordinated with interior partition walls.
3. Control joints shall be spaced no wider than 30 times the slab thickness.
4. Control joints are to be a depth of 1/3 the slab thickness.
5. If joints are to be saw cut, they must be sawed within 12 hours of concrete being poured if the overnight temperature is expected to be greater than 70° F, and within 24 hours in all other cases.

##### **A1035 Under Slab Drainage and Insulation**

- A. Basement drainage systems must be drawn and detailed to show the path of water from its source into some existing drainage structure. Consult Section G3030 – Storm Drainage Utilities.
- B. Drainage systems shall not rely on pumps or other mechanical means to remove water; instead, a positive gravity outfall situation shall be created.
- C. Drainage perforated piping shall include wrapping the pipe with a filter fabric sock and careful bedding of the pipe with the appropriate fill material.
- D. Use filter fabric over drain fields and at least 2” of stone under pipes.

**A20     Basement Construction****A2010   Basement Excavation**

## A2013   Shoring

- A. Shoring and/or sheet piling for basement excavation shall be designed by a Professional Engineer registered in the State of Alabama.

**A2020   Basement Walls**

## A2022   Moisture Protection

- A. For below grade waterproofing, use a composite self-adhering bitumen sheet membrane waterproofing system.
- B. Where shallow water table is indicated on soils report, a monolithic chemically adhered membrane or other similar system shall be specified by the Designer of Record or waterproofing consultant.
- C. All sheet waterproofing shall be protected by protection board/drainage mat assemblies.
- D. Waterproofing shall be terminated with a termination bar or liquid membrane per manufacturer's details at footings below grade and with counter flashings in the cavity wall assembly above grade.
- E. All waterproofing membranes must be installed to a minimum of 8" above the height of exterior finish grade.
- F. The exterior wall air/vapor barrier shall overlap the below grade waterproofing membrane to provide a continuous barrier.
- G. Wall joints below grade shall include a water stop.

## A2023   Basement Wall Insulation

- A. Provide block or board insulating materials recommended by manufacturer for the indicated application.

**Document Revision History**

Version	Section	Summary of Change	Date



## 2025 Section B – Shell

### INDEX

B10	Superstructure
B20	Exterior Enclosures
B30	Roofing
Document Revision History	

### LINKED DOCUMENTS

<a href="#">B20 – Exterior Enclosures</a>
---

## **B Shell**

### **A. General**

1. The minimum standard concrete mix shall be 3,000 psi.
2. Calcium chloride or admixtures containing chlorides shall not be used.
3. An approved air-entraining admixture shall be used for all concrete exposed to weather. When used, the concrete must be tested at the site immediately prior to placement to verify the proper amount of air-entrainment is present.
4. Aluminum/non-compatible conduits and pipes shall not be embedded in any concrete.
5. Reinforcing coverage in concrete must meet the requirements of the most current version of American Concrete Institute (ACI) 318.
6. Metal panels shall not have custom colors using mica or other similar materials. Provide Pantone Matching System (PMS) color code for all metals.

## **B10 Superstructure**

### **A. General**

1. Two-way post-tensioned flat plate and wood structural systems shall not be used. Exceptions for cross-laminated timber (CLT) construction may be acceptable with approval.
2. No lightweight structural concrete is to be used without prior approval.
3. All welded connections shall be made by an American Welding Society (AWS) certified welder. The use of "pre-qualified welds" is encouraged.
4. All structural steel in exterior locations (such as cornices, parapets, handrails, guard rails, or canopies) shall be hot dip galvanized.

## **B1020 Roof Construction**

- A. No lightweight insulating concrete shall be used in roof assemblies.

## **B20 Exterior Enclosures**

### **A. General**

1. A building envelope assembly mockup panel shall be provided as detailed by the Designer of Record, in the Construction Documents. The mockup panel shall be constructed by the appropriate Contractor(s) for approval of workmanship and final building envelope material approval and shall be built on site after the beginning of construction and prior to beginning the building envelope work. The materials used shall be provided by the project suppliers and shall represent the final product in all aspects. The panel shall be protected from construction operations but shall remain in place and exposed to the elements until all building envelope work has been approved by the Designer of Record and Owner.

2. Field Testing:
  1. Required on mockup assemblies for all new construction projects.
  2. The testing shall meet the following minimum standard:
    1. AAMA 501.2 for Storefronts, Curtain Walls, and Sloped Glazing Systems
    2. AAMA 502 for Punched Windows and Doors
  3. Minimum of 2 field tests required. One after installation and one at 50% project completion.
  4. Tests include, but are not limited to, air leakage, water infiltration, or adhesion (pull) tests for sealants.
  5. The University Project Manager and the Designer of Record are to collaborate to create a comprehensive list of required tests.

**B2010 Exterior Walls**

## B2011 Exterior Wall Construction

- A. Exterior Insulation and Finishing System (EIFS) and single-wythe uncoated concrete masonry unit walls are not acceptable.
- B. Brick masonry units with a smooth-faced texture free of blemishes is required. Any brick that is aesthetically blemished with cracks or chips may be considered for rejection or replacement. Special shapes shall be manufactured, not field cut.
- C. Provide tooled concave mortar joints.
- D. There shall be no site mixing of mortar colors. Bags shall come from the manufacturer with premixed colors with only sand and water added at the site. Sand shall be added in consistent amounts using a measured box rather than shovel counts.
- E. Where existing buildings are repointed, existing mortar and brick shall be tested for strength and composition to facilitate in determining replacement mortar type. Utilize the following testing standards:
  1. ASTM C1713 for Historic Mortar
  2. ASTM C270 for Unit Masonry
- F. Mortar Mix:
  1. Admixtures are not permitted.
  2. Temper of mix more than once not permitted.
- G. Stone shall match Indiana Limestone Company Empire Rustic Buff Smooth.
- H. Architectural precast concrete must be fabricated using the wet cast method.
- I. The Contract Documents shall note that the General Contractor is responsible for protecting the work during construction including physical protection and protection from temperature extremes.
- J. Through wall flashing assemblies:
  1. Shall consist of a stainless steel “base” pan and a 40-mil asphalt-modified waterproofing membrane.
  2. Shall be warranted by the manufacturer.
  3. The membrane shall be terminated on the stainless-steel base flashing 1” back from the exterior face of the masonry veneer.

4. Termination of the membrane at the dampproofed backup wall shall be a minimum of 8" above the drainage medium, approximately 16" above the shelf angle/horizontal projection.
5. Provide a continuous stainless steel termination bar or liquid termination at the top of the membrane flashing.
6. Stainless steel base flashing shall be 26-gauge, T304 alloy with 2D (dull) finish.
7. Flashing splice shall be at least 4" in length and covered with a third piece of stainless-steel base flashing, full bedded in sealant. The hemmed edge of the base flashing shall extend beyond the face of the masonry veneer.
8. Provide end dams at vertical terminations and dissimilar systems.
9. Acceptable manufacturers for through-wall flashing systems:
  1. WR Grace
  2. Polyguard
  3. Carlisle
- K. Provide flashing at all necessary locations; including window and door headers, shelf angles, parapets, roofing transitions and where masonry walls rest on a slab on grade.
- L. Provide full-height weep vents in the vertical joint.
- M. Two-coat Hylar resin finishes such as Kynar are preferred on metal wall panels.
- N. The 2-coat Hylar resin finish shall be provided with a 20-year warranty.
- O. Clear anodized aluminum finishes are not acceptable.
- P. If cavity wall construction utilizing light gauge framing and sheathing board is provided, seal joints between sheathing boards and apply 2" fiberglass mesh tape fully embedded in sealant, before damp proofing is applied. All products utilized must be compatible.
- Q. Wall Insulation and Vapor Retarder
  1. Provide rigid board insulation in the masonry cavity.
  2. Provide emulsion-based cavity wall damp proofing.
  3. All damp proofing systems must be water-based, and they must be applied pinhole free.
  4. The outer face of the inner wythe, or the entire face of the sheathing board shall be coated with damp proofing.
  5. Sealants behind the veneer wall (adjacent to damp proofing) shall be polyurethane.
  6. Acceptable manufacturers for damp proofing:
    1. Karnak
    2. Sonneborn
    3. WR Meadows
- R. Joint Sealants
  1. Use silicone sealants at exterior joints. Exterior joints shall be pull tested to determine that silicone is the most suitable product. A high-quality silicone and polyurethane hybrid sealant may be considered if silicone proves not to be suitable for exterior joints. Expansion joints shall be a minimum of ½" width and are not to exceed a ¾" width. Control joints shall be a width between 3/8" and 1/2". All tolerances of existing structures that do not meet

these requirements shall be reviewed for necessary changes to meet these requirements.

2. University Project Manager to define timeframe in which construction materials testing shall occur. If a standalone mockup is included, tests shall be performed on the mockup. If a mockup is excluded, tests shall be performed on first-in-place installations, in coordination with University Project Manager.
3. Provide the following sealant types at these exterior conditions:
  1. Masonry-to-masonry or Masonry-to-stone
    1. Dow 790
    2. Tremco Spectrum
    3. Pecora 890
  2. Metal-to-metal or Metal-to-masonry
    1. Dow Corning 795
    2. Tremco Spectrem 2
    3. Pecora 895
  3. Stone-to-stone or Metal-to-stone
    1. Dow 756
  4. CMU-to-CMU or CMU-to-concrete
    1. Sika Flex 2C
    2. Sonneborn NP-2
    3. Dymeric 240 FC
  5. Masonry flashing splice
    1. Dow Corning 795
    2. Tremco Spectrem 2
    3. Pecora 895

#### B2012 Parapets

- A. Parapet heights shall be sized to meet the minimum of 42" height above the finished roof system.
- B. Precast coping systems shall have minimum skyward sealant joints with minimum 40 mil high temperature waterproofing underlayment that overlaps with a continuous and compatible building envelope waterproofing system.
- C. All metal coping systems shall consist of a minimum of 24 gauge for coping covers, anchor plates with integral support chair (18 gauge for galvanized steel or .063" aluminum) installed at 5'-0" on-center. Coping systems must be a concealed fastener snap-on coping, ANSI/SPRI/FM 4435/ES-1 Certified. Coping covers shall be manufactured for positive drainage. Anchor plates shall be galvanized steel or aluminum to accommodate any inconsistencies in the walls. Custom mitered corners shall be included.

**B2020 Exterior Windows****B2021 Windows**

- A. Window frames shall be extruded (not unitized) aluminum and of weather-tight design.
- B. Windowsills shall be masonry, stone, or architectural precast concrete.
- C. The bottom of windowsills shall be considered for a minimum 8' above a finished exterior horizontal surface to allow flashing height for roofing and waterproofing systems.
- D. Exterior window wall assemblies for multiple stories shall be curtain wall construction.
- E. Punched window openings can utilize pre-manufactured window waterproofing systems provided they meet the following minimum criteria:
  - 1. Have flange for secondary water control.
  - 2. Minimum air filtration of .06 cfm/sq. ft when tested at 6.24 psf.
  - 3. No water penetration when tested at 10 psf.
- F. Do not fasten window heads up through shelf angles.
- G. Glazing
  - 1. When insulating glass is used, it shall be hermetically sealed to prevent condensation between the two layers of glass and shall have a minimum 10-year warranty.
  - 2. Gaskets for storefront and curtain wall systems shall be high performing gaskets and factory applied sealants that avoid shrinkage and failure during the lifespan of the window.

**B2030 Exterior Doors**

- A. General
  - 1. Doors shall have a maximum height of 8'-0" and a minimum height of 6'-8".
  - 2. All doors shall have a minimum width of 3' 0".
  - 3. Doors shall be standard 3'x 7' where possible.
  - 4. Exterior doors shall be aluminum or galvanized 16-gauge hollow metal steel.
  - 5. Frame shall be welded and ground smooth.
  - 6. Knock down or unwelded frames are not acceptable.
  - 7. Vertical rod door hardware devices are not acceptable.
  - 8. Roof access doors shall be installed a minimum 8" above the finished roof system.
  - 9. Single-leaf door openings are preferred to double-leaf door openings. If double-leaf door openings are required by the project, provide a keyed removable mullion.
  - 10. Aluminum storefront doors shall be wide-stile only with a 12" bottom rail.
  - 11. Exterior Doors shall be provided with electrified panic hardware and shall be monitored by the access control system.
  - 12. Exterior openings which are not hinged such as large sliding or overhead coiling doors shall be monitored.

13. All exterior doors shall be capable of real-time remote programming and/or monitoring by the Auburn University Access Control Center and the Auburn University Department Campus Safety and Security.
- B. Door Hardware
  1. Refer to Auburn University [Door Hardware Standards](#) document.

### **B30 Roofing**

- A. Exposed fasteners are not acceptable on metal roofing assemblies, unless specifically approved in writing by the University Project Manager.

### **B3010 Roof Coverings**

#### **B3011 Roof Finishings**

- A. High Slope Roofing
  1. Roofing assemblies with a slope greater than 4:12 are steep (high) slope roofs.
  2. Asphalt shingles installed over a breathable synthetic underlayment and an ice and water shield is the preferred roofing assembly for pitched roofs. Shingles shall be dimensional architectural shingles with a 30-year warranty from the shingle manufacturer. Colors with SRI greater than 29 desired but are subject to approval by University Project Manager. Asphalt shingles shall be nailed to min. 5/8" exterior grade CDX board and include a vented roof deck. The shingle roof system that is chosen shall include assembly components from the same shingle manufacturer.
  3. Acceptable asphalt shingle manufacturers include:
    1. GAF
    2. Tamko
    3. Owens Corning
    4. Additional manufacturers as recommended by the Designer of Record and approved by the University Project Manager.
- B. Low Slope Roofing
  1. A low slope roof is one that has a pitch between 1/4:12 and 3:12. 3:12 can be considered as pitched roof with special attention given to underlayment.
  2. All low slope roofs should be a minimum of 1/4:12 with positive pitch to drains.
  3. A minimum of 4'-0" by 4'-0" insulated drain sumps shall be installed at all drains, except for overflow drains.
  4. When low-slope roofs are approved for use, they shall be provided with a minimum slope of 1/4" per foot and shall be a fully adhered or torch applied 2-ply SBS modified bitumen roof system. Polymethyl Methacrylate (PMMA) reinforced fluid applied flashing shall be used with modified roof systems at drains, curbs, pipe penetrations and irregular roof details. All flashing shall terminate a minimum of 8" above the finished roof surface. All seams at the cap sheet shall be heat welded. Damage to the seams during heat welding shall not be permitted.

5. Use of modified bitumen flashing as curb/wall flashing shall not be accepted with exposed termination bar and sealant unless covered with approved through-wall counterflashing.
6. Use of pitch pockets as flashing details for modified bitumen roof systems shall not be permitted.
7. Use of modified bitumen as flashing at pipe penetrations shall not be permitted.
8. Approved modified bitumen low-slope roofing manufacturers with Polymethyl Methacrylate (PMMA) fluid applied flashing include:
  1. Soprema
  2. Siplast
  3. Johns Manville
9. When low-slope roofs do not have roof-top equipment and are pre-approved for use, they shall be:
  1. Provided with a minimum slope of  $\frac{1}{4}$ " per foot.
  2. Fully adhered, heat welded, 60 mil minimum thickness reinforced single ply thermoplastic membrane or polyvinyl chloride thermoplastic membrane with Kee.
  3. Fleece back membrane preferred but optional with approval of University Project Manager.
  4. Exposed termination bar and sealant shall not be considered unless covered with approved through-wall counterflashing.
10. Approved low-slope roofing manufacturers include:
  1. Fibertite
  2. GAF
  3. Firestone Building Products
  4. Johns Manville
  5. Carlisle
  6. Additional manufacturers as recommended by the Designer of Record and approved by the University Project Manager.
    1. All Designers of Record and/or General Contractors requesting the use of alternate manufacturers owned by Firestone and Carlisle must be certified directly as Firestone and Carlisle system installers and must meet financial requirements of certified Firestone and Carlisle manufacturer approved installers.
11. All modified bitumen low-slope roofs must carry a minimum of a 20-year, no dollar limit roof system warranty.
12. Before the project begins, the manufacturer of the roof system must submit an assembly letter to be included with the product data sheets.
13. New rigid insulation shall be of type and installation method required for manufacturer providing warranty. Thickness shall be determined as required to meet applicable energy codes and shall be attached to structural roof deck as required by roofing manufacturer to meet wind uplift design criteria for geographical area. Provide  $\frac{1}{2}$ " cover board as required by manufacturer.

14. The manufacturer of the roofing must submit a letter to the University Project Manager certifying that the entire roofing assembly is compatible and complete as required for warranty requirements.
15. Secondary slope to roof drains shall be provided within two feet of the primary roof drain. Roof drains shall be kept protected from debris.
16. At the end of the day's work, or when precipitation is imminent, a night seal must be installed at all open edges.
17. Prior to final inspection, the General Contractor shall conduct a flood test or electrical conductance test of the roof in the presence of the Designer of Record and the University Project Manager to verify drainage. At final inspection, representative of roofing materials manufacturer providing warranty to be present with Designer of Record, University Project Manager, General Contractor, and Roofing Subcontractor where applicable.
18. Pedestrian walk pads shall be installed at all egress, access ladders and perimeters of roof top equipment. Paths with walk pads shall be considered where maintenance foot traffic exists.

#### B3012 Traffic Toppings & Paving Membranes

- A. When low-slope roofs are approved for use with complete overburden, such as pedestals and pavers or vegetative systems, the membrane system shall be provided with a minimum slope of 1/8" per foot to all drains and shall be a fully torch-applied, 2-ply SBS modified bitumen roof system with the top membrane a min. 154 mils. Full adhesion of the 2-ply modified bitumen membrane may be considered with solvent free adhesive. Polymethyl Methacrylate (PMMA) reinforced fluid applied flashing shall be flashed with modified roof systems at drains, curbs, pipe penetrations and irregular roof details. Flashings shall terminate a minimum of 8" above the finished roof surface. The roofing assemblage shall be covered under a single manufacturer's warranty.
- B. Acceptable fluid applied low-slope roofing manufacturers with Polymethyl Methacrylate (PMMA) fluid applied waterproofing include:
  1. Soprema
  2. Siplast
  3. Johns Manville
  4. Kemper
- C. Hot rubberized asphalt shall not be permitted.

#### B3016 Gutters and Downspouts

- A. Built-in gutters and systems which bring roof water into the envelope of the building shall be avoided.

**B3020 Roof Openings****B3022 Roof Hatches**

- A. If the lowest point of the roof is not consistently accessible within 24 feet of the ground, a rooftop hatch or door shall be provided to facilitate access for roofing maintenance.
- B. Ladders inside closets are not acceptable for roofs with equipment that requires maintenance. Permanent stairs shall be built into the structure for roof access.
- C. Roof hatches must be no closer than 12 feet from the roof edge.
- D. Roof hatches shall not be installed in any electrical room or other room with moisture sensitive equipment such as telecom, data, security, or access control equipment rooms.
- E. Provide built-in personnel tie-off points into the roof design for the purposes of construction and maintenance. Use dark bronze in color or other similar color to blend with the roof color. Tie-off points shall be provided within and immediately outside the roof hatch.
- F. Davit arms are not permitted.

**B3023 Gravity Roof Ventilators**

- A. Roof top equipment shall be located no closer than 16 feet to the roof edge. If any equipment requiring service is located within 10 feet of the roof edge, fall-protective railings shall be provided. Fiberglass railings are not permitted.

**Document Revision History**

Version	Section	Summary of Change	Date



## 2025 Section C – Interiors

### INDEX

C10	Interior Construction
C20	Stairs
C30	Interior Finishes
Document Revision History	

### LINKED DOCUMENTS

<a href="#">C10 – Interior Construction</a>
---

## C Interiors

### C10 Interior Construction

#### C1010 Interior Partitions

##### C1011 Fixed Partitions

- A. No wood studs.
- B. Minimum thickness = 5/8" gypsum board.
- C. Provide 5/8" Type X gypsum board on minimum 3-5/8" 20-gauge metal studs, at 16" on-center, with snap-in 1-5/8" cold rolled channel stiffeners through studs at mid-span to facilitate future rewiring. Brace studs to structure for additional stiffness as needed.
- D. Where finished partitions are furred out from concrete or masonry back-up, provide minimum 7/8" furring channels and 5/8" gypsum wallboard.
- E. Designer of Record shall indicate on the drawings or provide in the specifications for shop drawings to indicate control joints for gypsum board-finished walls greater than 30-feet in length. Control joints should be located logically and align with other elements whenever possible.
- F. Provide fire-retardant treated wood blocking to facilitate installation of grab bars, wall stops, similar accessories or other built-in work. Provide details on the drawings to accommodate built-in elements of varying weight.
- G. Gypsum board shall not touch the floor. Provide 1/2" clearance.
- H. Provide fiberglass mat (moisture resistant) gypsum board in areas where water is present, such as bathrooms, kitchens, and laboratories.
- I. Extend partitions through ceiling and anchor to structure above. Do not terminate partitions at ceiling grid without prior approval. If approved, trim top edge of gypsum board partition with ceiling system "L" trim, white finish.
- J. Extend all corridor partitions and finish to structure.
- K. Designer of Record shall design stairs such that usable space beneath the stairs is discouraged/not possible/prohibited.
- L. Acoustics shall be considered in appropriate areas for comfort, presentations, and privacy. Provide for sound control around offices, conference rooms, restrooms, and other sensitive areas. Consult with University Project Manager and End User to determine acoustic strategy.
- M. Provide corner guards in high traffic and utility corridors.
  - 1. Laboratory and classroom buildings
    - 1. 4' - 0" high stainless steel corner guards.
  - 2. Administrative and classroom buildings
    - 1. 4' - 0" high vinyl corner guards.
  - 3. Residence Halls
    - 1. 8' - 0" high vinyl corner guards.
  - 4. Dining Facilities
    - 1. 4' - 0" high stainless steel.

## C1017 Interior Windows &amp; Storefronts

- A. Provide tempered or laminated safety glass.
- B. Intumescent fire-glass for glazing in fire-rated partitions. Use of wire glass is not permitted in new construction.

**C1020 Interior Doors**

## C1021 Interior Doors

- A. Provide solid core wood, maple, birch, or oak veneer doors with transparent finish, except that existing adjacent door veneers shall be matched in remodeling projects.
- B. Painted doors are acceptable in Residence Hall facilities. Must be semi-gloss paint.
- C. Doors taller than eight (8) feet shall be approved by the University Project Manager.
- D. Single-leaf door openings are preferred to double-leaf door openings. If double-leaf door openings are required by the project, provide a keyed removable mullion.
- E. Aluminum storefront doors shall be wide stile only with a 12" bottom rail.
- F. All doors leading to secure areas shall be capable of real-time remote programming and/or monitoring by the Auburn University Access Control Center and the Auburn University Department Campus Safety and Security.
- G. Where interior spaces require large doors for the passage of equipment (e.g. general laboratories, shared equipment laboratories, etc.), specify 3'-6" or 4'-0" single leaf doors (with appropriate adjustments in frame gauge and hardware requirements) rather than pairs of 3'-0" + 1'-0" doors.

## C1022 Interior Door Frames

- A. Provide welded and formed 16-gauge steel hollow metal interior door frames.
- B. Knock down or unwelded frames are not acceptable.

## C1023 Interior Door Hardware

- A. Refer to Auburn University [Door Hardware Standards](#).

## C1025 Interior Door Wall Opening Elements

- A. Provide either a vision lite in each door or side lite to an office, conference room, or similar spaces as deemed necessary for safety reasons.

**C1030 Fittings****C1031 Fabricated Toilet Partitions****A. Toilet and Shower Partitions**

1. Stainless steel, smooth-faced partitions floor mounted. In locations subject to high humidity, such as locker rooms or shower rooms, Phenolic or HDPE partitions may be specified with the Designer of Record's approval.
2. Provide heavy-duty stainless-steel trim and hardware with self-closing door hinges.
3. Latches that do not depend on precision alignment of door and wall to operate are preferred.
4. Provide bumper and hooks on back of stall doors.

**C1035 Identifying Devices****A. Emergency Evacuation Map plans shall be installed in the following locations:**

1. Each stairwell at each level.
2. Each elevator landing.
3. Each building entrance immediately inside the building.

**B. Provide interior signage for all assigned spaces, to include:**

1. Life safety sign requirements.
  1. Every exit and path of egress
  2. Stairs
    1. Keep Door Closed signage inside stair landings
2. Public toilets and ADA compliant toilets
  1. In addition to room identification signage, pictograms shall be installed at all restrooms.
3. Rooms
  1. Mechanical
  2. Electrical
  3. Telecommunications
  4. Custodial
  5. Other service rooms, as applicable.
  6. Specific fire protection specialty rooms:
    1. Special white letters on red background:
      1. "FACP" for rooms with fire alarm control panels.
      2. "SPRINKLER RISER" for rooms with fire sprinkler risers.
      3. "FIRE PUMP ROOM" for rooms with fire pumps.
4. ADAAG (Americans with Disabilities Act Accessibility Guidelines)
  1. Provide signage with Grade 2 Braille at all permanent rooms and spaces and other areas as required by ADAAG.
  2. Maintain the required spacing of the Braille text from the raised print text.
  3. The size and layout of pictograms shall conform to all ADAAG requirements.

4. A representative sign sample must be submitted prior to the full production run to demonstrate ADAAG compliance.
  5. Signage shall be installed at the height required by ADAAG and placed 2" from the strike-side edge of the door frame. If signage is required to be installed on glazing, double-stick tape and a 1/8" aluminum backer plate on the opposing side of the glazing shall be provided. Backer plate color to complement the signage color.
- C. Standard Signage shall be equal to items listed below from Gravograph New Hermes. (2200 Northmont Parkway Duluth, GA 30096-5895; 1-800-843-7637)
1. Deluxe Directory
    1. Header Plus Three Insert Lines: Part No. 34911
    2. Header Size: 2" High x 7" Wide x 1/16" Thick
    3. Insert Size: 3/4" High x 7" Wide x 1/16" Thick
    4. Overall size: 4 3/4" High x 7 5/8" Wide x 3/8" Thick
- D. Interior Signage shall match existing within the building or shall match these standards:
1. Gravotac Silver Grey (substrate) used for Braille room numbers and backplate material on which to mount raised profile numbers. Material Part number 29900.
  2. Gravotac Bright White Profile material for profile numbers Part number 37042A (request with adhesive).
  3. Gravoply-I material for 3 lines Part Number 29584, Silver Gray with white core.
  4. Gravotac Black (substrate) Part Number 29902. \*Use same Bright White listed above for all profiles. Gravoply Black for 3 lines, Part Number 17319.
  5. Gravoply Grey (not Silver Gray). Use same material for substrate and 3 lines, Part Number 21927.
  6. Use raster beads inserted into backplate for Braille. Part Number B9040CB. These come from Accent Signage, Minneapolis, MN 55405.

#### C1037 General Fittings and Miscellaneous

- A. Toilet and Bath Accessories
1. All towel holders, toilet paper dispensers, and soap dispensers shall be Owner Furnished, Contractor Installed (OFCI). Design documents shall indicate the location of the toilet accessories.
    1. [Campus Standard Paper Towel Dispensers with Dimensions](#)
    2. [Campus Standard Soap Dispenser with Dimensions](#)
    3. [Campus Standard Toilet Paper Dispenser with Dimensions](#)

**C20 Stairs****C2020 Stair Finishes**

## C2021 Stair Tread and Landing Finishes

- A. Stair risers and treads shall be solid material.
- B. Stairs shall be finished with premium grade rubber treads.
- C. Compatible sheet rubber flooring may be used on landings.
- D. Risers may be painted or use an integrated rubber riser and tread.
- E. Service and non-public stairs may be finished with sealed concrete in metal pan forms and shall have an aluminum nosing with integral abrasive strips.
- F. Provide a closure angle between stair stringer and adjacent wall.

**C30 Interior Finishes****C3010 Wall Finishes**

## C3012 Wall Finishes to Interior Walls

- A. Gypsum Finishes
  - 1. Designer of Record to provide specified finish level on design documents and in accordance with Gypsum Association's publication Recommended Levels of Gypsum Board Finish (GA-214-96).
  - 2. Corridors and stairwells – Level 4 finish and semi-gloss enamel paint.
  - 3. Offices and conference rooms – Level 4 finish and low luster or eggshell latex paint.
  - 4. Toilet Rooms and Showers – Fiberglass mat wallboard and ceramic or other hard tile full height on wet walls. (See tile section for specific requirements regarding base and transition). Painted walls to be semi-gloss in high moisture spaces, eggshell in toilet rooms.
  - 5. Kitchens, Foodservice Venues and Break Rooms – Fiberglass mat wallboard and porcelain or quarry tile or epoxy paint on CMU. Painted gypsum wallboard is unacceptable.
  - 6. Mechanical Rooms, Electrical Rooms, Elevator Control/Machine Rooms, Custodial Rooms, and I/T Rooms - Epoxy paint on CMU is preferred. If gypsum wallboard is provided, a Level 4 finish and epoxy paint shall be provided.
  - 7. Special Rooms – Some spaces are too specialized to list in the Design Standard. If a non-listed space is included within a project, the Designer of Record shall recommend the appropriate finishes for approval by the University Project Manager.
  - 8. Exposed metal studs without a finish are not acceptable.
- B. Paint
  - 1. Flat wall paint is unacceptable.
  - 2. Provide paint products by one of the following manufacturers:
    - 1. Sherwin Williams

2. Benjamin Moore
  3. Scuffmaster
  4. Other manufacturers with similar high-quality products may be submitted to be approved by the University Project Manager during the design phase.
- C. Wall Coverings
1. Type II mold and mildew resistant products with micro-perforations shall be provided.
- D. Acoustical Panels
1. Class A flammability rating
  2. If digital images printed on acoustical panels are specified, images shall be approved by the University Project Manager.
  3. Panels shall meet or exceed NRC of 0.80.

### **C3020 Floor Finishes**

- A. General
1. Flooring shall be durable and easy to maintain.
  2. Polished concrete shall not be used for finished floor, except in back of house or service areas.

### **C3021 Floor Toppings**

- A. Tile
1. Toilet Rooms and Showers - ceramic or other hard tile, sheet vinyl, or sealed concrete on the floor with 6" minimum cove base.
  2. If Schluter Industries cove strip is specified, tile above must maintain the 6" minimum height. Cut tile should be capped using Schluter Industries or equal cove strip.
  3. 3"x12" bullnose is not acceptable alternative to cove base.
  4. Tile base shall follow wall, with minimal grout line along top of base. Must be installed via TCNA standards.
  5. Kitchens, Foodservice Venues, and Break Rooms - ceramic or quarry tile or sealed concrete with 6" minimum cove base.
  6. Ceramic/porcelain hard tile:
    1. All specified tile must meet or exceed industry standards.
    2. Dynamic Coefficient of Friction (DCOF) Slip resistance of tile
      1. ANSI A326.3-2021 (section 6.2)
    3. Abrasion resistance data to equal:
      1. ASTM C1027-19 Class Four or Class Five
    4. Scratch hardness:
      1. Value of 7 or greater
    5. Water absorption data to equal:
      1. ASTM C373-18(2023)
    6. Breaking strength data to equal:
      1. ASTM C648-20

7. Chemical resistance data to equal:
    1. ASTM C650-20
  8. Porcelain tile is recommended over ceramic tile for flooring application.
  9. Dark grout is preferred. Grout should be thoroughly mixed per the manufacturers specifications to ensure consistent color throughout mixture and application.
  10. Epoxy mortar and grout (epoxy or equal) shall be provided by Contractor.
  11. Grout joints shall be per the tile manufacturer recommendation.
  12. Grout and tile sealer shall be provided by Contractor.
  13. Grout caulk shall match color of grout and be from the same manufacturer.
- B. Resilient Flooring
1. Hard flooring, such as VCT, luxury vinyl flooring, ceramic or other hard tile shall meet requirements for slip resistance and durability.
  2. Laboratories
    1. Heavy duty sheet seamless flooring with integral base.
  3. Closets, Storerooms, and File rooms
    1. VCT with 4” resilient base.
  4. Mechanical Rooms, Electrical Rooms, Custodial Rooms, and IT Rooms
    1. VCT or sealed concrete with 4” resilient base.
  5. Vinyl Composition Tile:
    1. 12 in. x 12 in.
    2. 1/8 in. thick
    3. Static Load limit of 125 psi
    4. Fire test data to equal:
      1. ASTM E 648 Critical Radiant Flux - .045 watts/cm<sup>2</sup>
      2. ASTM E 662 Smoke – 450 or less
    5. Provide a five-year warranty.
    6. Provide waterproof setting materials for flooring applied to below grade floor slabs and other assemblies as recommended by the Designer of Record.
    7. VCT flooring shall be scrubbed to remove factory finish and then waxed with 4 coats of wax. Wax specification to be coordinated by University Project Manager.
    8. Newly waxed VCT flooring shall be burnished with a hog’s hair pad by a high speed burnisher at 1500-2000 rpm.
  6. Luxury vinyl flooring:
    1. All specified products shall meet or exceed industry standards set by ASTM F 1700 Class III Solid Vinyl Tile.
    2. Product should meet the following:
      1. 20 mil wear layer.
      2. Overall gauge of .120” (3mm) nominal, 5mm is also acceptable.
      3. 20 Year commercial warranty.

## C. Entrance Flooring

1. Building entrances shall have a built-in water walk off mat with a minimum length of 7 feet. In new construction, the walk off mat shall be recessed into the structure, or flush without transition to building flooring. Renovations may provide for a removable mat to lie on the finished floor.

## C3023 Hardeners and Sealers

- A. All hard surface flooring shall be sealed in accordance with the manufacturer's written instructions.

## C3025 Carpeting

- A. Carpet shall be commercial-grade, high-density with low pile height.
- B. Provide carpet flooring and resilient wall base for offices and conference rooms.
- C. Broadloom Carpet Products:
  1. Rated for heavy traffic with soil, stain protection, red dye stain resistant.
  2. 22-34 ounce face weight.
  3. Nylon fiber type 6 or 6-6 or equal.
  4. Level loop or multi-level loop.
  5. When padding is used it shall be integral with carpet.
  6. Solution dyed yarns.
  7. Carpet shall contain pre-consumer and post-consumer recycled content. Carpets containing pre-industrial and post-industrial recycled content are preferred.
  8. Install using a direct-glue method, in accordance with manufacturer's written instructions.
- D. Carpet Tile Products:
  1. Rated for heavy traffic with soil, stain protection, red dye stain resistant.
  2. 22-34 ounce face weight.
  3. Nylon fiber type 6 or 6-6.
  4. Solution dyed.
  5. Use cushion back tiles as circumstances require, such as in an area where acoustics are important.
  6. Carpet shall contain pre-consumer and post-consumer recycled content. Carpets containing pre- and post-industrial recycled content are preferred.
  7. Install using a "releasable" glue system, "peel and stick," or tackable dots, in accordance with manufacturer's written instructions. Direct-glue method is unacceptable.
  8. Installation adhesive or system shall be from same manufacturer as carpet materials.
- E. Recycled Content
  1. Contractors should make every effort to recycle all removed vinyl-backed carpet tiles and luxury vinyl tile (LVT).
  2. Material should be free of debris with no hazardous or non-recyclable content and submitted to an appropriate reclamation agency.

**C3026 Base, Curbs, and Trim**

- A. Base shall be 4" or 6" resilient, tile or wood base as appropriate to the flooring type and project design.
- B. Resilient wall base shall be continuous roll 4" or 6" cove base. Precut lengths are not acceptable.
- C. Outside and inside corners shall be formed by using the continuous roll base.
- D. Do not provide sections of base that are less than 6' in length.
- E. Resilient wall base shall have round top or flat top and shall be specified within the design documents.
- F. No toe base is acceptable at carpet floor surfaces.

**C3030 Ceiling Finishes**

- A. General
  - 1. Ceilings shall be accessible.
  - 2. Access panels are required in hard ceilings for any serviceable device located above the ceiling. Access panels shall be detailed and located on Construction Documents.
  - 3. If gyp ceiling is specified, ceiling shall be painted using flat paint.

**C3032 Suspended Ceilings**

- A. Acoustical Ceiling
  - 1. Ceiling Grid
    - 1. 2' x 2' or 2' x 4'
    - 2. 15/16" wide intermediate-duty,
    - 3. Hot dip galvanized with standard white finish.
    - 4. Grid systems in high humidity/unconditioned spaces, kitchens, foodservice venues, or other specialized spaces shall be aluminum, unless otherwise recommended by the Designer of Record.
    - 5. Suspend ceiling grid from structure only.
    - 6. Ceiling grid mains to be tied to structure within 8" of each end. Or seismic clip to be provided at each end.
  - 2. Ceiling tile
    - 1. 2' x 2' or 2' x 4'
    - 2. 3/4" thick, white tegular-edge Armstrong Cirrus.
    - 3. Ceiling tile in high humidity/unconditioned spaces, kitchens, foodservice venues, or other specialized spaces shall be Armstrong Fine Fissured Ceramaguard with hold down clips, unless otherwise recommended by the Designer of Record.
    - 4. In renovation projects, match the existing tile if available.
  - 3. Acoustical ceiling tile shall not be installed until all work above ceilings has been completed, inspected, approved by the University Project Manager and temperature and humidity are consistently maintained as indicated for final occupancy.

**Document Revision History**

Version	Section	Summary of Change	Date



## 2025 Section D – Services

### INDEX

D10	Conveying
D20	Plumbing
D30	HVAC (Heating, Ventilation, and Air-Conditioning)
D40	Fire Protection
D50	Electrical
Document Revision History	

### LINKED DOCUMENTS

<a href="#">D10 - Conveying</a>
<a href="#">D20 - Plumbing</a>
<a href="#">D30 - HVAC (Heating, Ventilation, and Air-Conditioning)</a>
<a href="#">D50 - Electrical</a>

## D Services

### D10 Conveying

#### D1010 Elevators and Lifts

##### D1011 Passenger Elevators

- A. All elevator specs to be reviewed by Auburn’s elevator consultant prior to design acceptance.
- B. Warranty period and maintenance period to be one year and coincide with General Contractor’s warranty.
- C. Elevators to comply with ANSI A17.1 and ADA/ADAG.
- D. Elevator certifications shall be witnessed by the University Project Manager.
- E. If there is an attic or penthouse level, the elevator shall service this level.
- F. Non-public spaces shall be accessible by card reader access only.
- G. Enclosed machine rooms for hydraulic elevators shall provide supply and exhaust air to prevent oil film build-up on machinery components and reduce the potential hydraulic smell to the room.
- H. All new and renovated elevators shall have air conditioning and humidity controls in the control cabinets or equipment rooms. Shaft ways exposed to exterior environment (i.e. parking garages) shall be provided with humidity control to prevent water condensation on rails and operating mechanisms. The spaces shall maintain a temperature range between 68° to 84° Fahrenheit year-round.
- I. For passenger elevators, the elevator speed shall be no less than 150 FPM. For freight elevators, the speed is to be determined according to project needs.
- J. Provide Automatic Fireman’s Recall System; in general, operation shall comply with attached Elevator Recall/Shutdown Matrix for sprinklered and non-sprinklered buildings. See [Elevator Recall Matrix](#).
- K. Provide hall lanterns at each landing or car riding lanterns in both entrance columns and provide the car position indicator in the main floor of egress hall station, minimum 2” in height.
- L. Elevator cab lighting and exterior lanterns shall be LED light fixtures.
- M. Provide all special diagnostic equipment, meters, or monitors manuals needed to trouble shoot or repair elevators to the University. Proprietary equipment, computer hardware and software, shall not be used. Provide all user and service codes for all diagnostic equipment with instructions.
- N. Elevator Service and Repair Manuals
  1. Two service and repair manuals for all elevators must be submitted.
  2. Service manual must include all diagnostic information.
  3. An owner’s manual must be provided to the University.
  4. One of the three sets of wiring diagrams must be laminated.
  5. All items must be turned over to the University Project Manager upon completion.

6. After the one-year warranty period, all service records, manuals, and diagnostic equipment must be turned over to the University and signed for by the University Project Manager.
- O. Provide key locks for independent service, fire service inspection, and lighting and fan (four keys for each lock). Fixtures shall be provided by Innovation Industries Bruiser Line. The emergency stop switch shall be a Double D Core.
- P. Access to elevator equipment rooms shall be restricted.
- Q. Card Reader provisions shall be provided on all elevators in the controller and travel cable. Wiring coordination required with Auburn University OIT through the project's UPM. The system shall be Auburn University supplied and installed by the elevator contractor. Controller must be able to differentiate individual badges/fobs to individual floors as necessary by design.
- R. Provide three copies of the "Certificate of Operation" to the University Project Manager – one to be posted in the elevator cab, one for the University Project Manager, and one for Maintenance and Operations.
- S. All elevator controls shall be of a non-proprietary type. Approved control suppliers:
  1. Elevator Controls: Pixel
  2. Motion Control Engineering: I-box
  3. GAL Manufacturing: Galaxy IV
- T. All elevator controls to be microprocessor logic type. Provide in the service manual a ladder diagram or other source code, relay wiring diagram, showing all relays, devices, and switches. The drawing set shall include electrical schematic diagrams and input/output schedules.
- U. Elevator control logic for electric traction elevators to be independent or component control logic.
- V. Elevator Emergency Communication Equipment to be non-proprietary. Approved equipment:
  1. WURTEC -Wur-com Elevator Communication System
    1. Wurtec Wur-com ethernet Adapter P/N 11-10072111
    2. Wurtec Wur-com UPS P/N 11-10071546
  2. WURTEC - Wur-com Plus Elevator Communication System
    1. 2n Liftgate w/Ting SIM card (Yellow Box) P/N 11-702-LG-VER
- W. Hydraulic elevators to be equipped with a sealed PVC cylinder sleeve.
- X. Elevator machine and control rooms shall not be located near classrooms or sound sensitive areas.
- Y. Permit shall be paid for out of project that installs elevator.
- Z. Permits shall be applied for in advance of completion to avoid any unnecessary delays in the permitting process.
- AA. No floor drains are permitted in any elevator machine room.
- BB. All elevator pits shall be sealed and watertight, with minor slope to the sump pit. Sump to be located in a rear wall corner. Sump pit must be a minimum of 2' x 2' x 2' with a galvanized steel grate cover.
- CC. Provide an oil cooler as needed.
- DD. Elevator Sprinkler/Detector Matrix
  1. [Elevator Fire Protection](#)

## EE. Elevator Recall/Shutdown Matrix

1. [Elevator Recall Matrix](#)

**D20 Plumbing**

- A. Building piping main runs shall be located above the corridors unless otherwise approved by University Project Manager.
- B. Install all piping parallel or perpendicular to building lines with sufficient hangers to prevent sagging.
- C. Pipe Label Requirements
  1. [Pipe Labels](#)
- D. Floor penetrations are to have leak protection.
  1. Cast in place.
    1. Schedule 40 steel pipe. 2" above floor. Flush with bottom of slab.
  2. Cored penetrations.
    1. Schedule 40 steel pipe nipple bolted to floor and caulked around perimeter.
  3. Multiple cored penetrations.
    1. 2" angle iron around openings, bolted to floor and caulked around perimeter.
- E. Isolation Valves
  1. Provide isolation of each floor or section of a floor.
  2. Provide isolation valves for all services into bathrooms, laboratories, and mechanical rooms spaces to allow for area isolation.
  3. Provide isolation of each independent item of equipment and fixture.
  4. Ball valves preferred for pipe  $\leq 2.5"$ .
- F. All valves, including balancing valves, to be tagged with brass tags. Provide a chart noting all valve locations along with identifier, type, and location on as-built drawings.
- G. Lead Free Identification - All piping, fittings, valves, and fixtures of the domestic water system must be clearly labeled with permanent identification of compliance with the Safe Drinking Water Act as lead free.
- H. Water Meters:
  1. Provide water meter schedule to indicate each water meter required for project. Schedule the following information:
    1. Service: (domestic, make-up, etc.)
    2. Size of Meter
    3. Non-Return Meter: Y/N
    4. Minimum Design Flow (gpm)
    5. Maximum Design Flow (gpm)
    6. Location of Meter
  2. [Water Meter Detail](#)

**D2010 Plumbing Fixtures**

## D2011 Water Closets

- A. Water Closet to be vitreous china, wall hung with chair carrier.
- B. Water Closet bowl shall be elongated.
- C. Water Closet passage to be a minimum diameter of 2.25" trap-way.
- D. Water Closet seats to be solid plastic with stainless steel self-sustaining check hinges.
- E. Water Closet water supply connection shall be top spud type with a minimum inlet diameter of 1".

## D2012 Urinals

- A. Urinals to be vitreous china, wall hung with floor mounted carrier, low flow design sensor type with 1 pint per flush.
- B. Urinal passageway shall be a minimum diameter of 2".
- C. Urinal water supply connection shall be a top spud type with a minimum inlet diameter of 3/4".

## D2013 Lavatories

- A. Wall hung lavatories to be vitreous china and shall be provided with concealed arm carrier.
- B. Restroom lavatory faucets in new construction and renovations to be chrome plated with auto-operation sensor.
- C. Power source for the faucet (in order of preference):
  - 1. Hardwired from Power Converter (Mini junction box can be used to power up to 8 faucets).
  - 2. 6 VDC Plug-In Power Converter (Requires receptacle under sink).
  - 3. Battery powered.
- D. Faucets shall not contain plastic components.

## D2014 Sinks

- A. Kitchen and Breakroom Sinks
  - 1. Sinks to be 18 gauge stainless steel.
  - 2. Sink faucets to be ¼ turn ceramic disk cartridge type with 4" minimum length wrist blade handles.
  - 3. Faucets shall not contain plastic components.
  - 4. Kitchen faucets shall have a maximum flow rate of 1.8 gpm.
  - 5. Sink disposal not allowed in non-commercial kitchens.
- B. Custodial Room Mop Sinks and Basins
  - 1. Mop service basins shall be floor/wall assemblies.
  - 2. Basin shall be a one-piece terrazzo construction.
  - 3. Basin shall be equipped with aluminum or stainless bumper guards.
  - 4. Basin shall be equipped with a mop hanger bracket.

5. Basin shall be equipped with a service faucet complete with vacuum breaker, integral check valves, integral stops, an adjustable wall brace, a pail hook, and a 3/4" hose thread on spout.
6. Basin shall be equipped with a hose and hose bracket.
7. Basin shall be equipped with stainless steel wall guards.
8. Basin and wall guards shall be sealed watertight to the wall and floor.

**D2017 Showers**

- A. Shower heads.
  1. Maximum flow rate of 1.5 gpm.

**D2018 Drinking Fountains and Coolers**

- A. Water Cooler and Bottle Filler
  1. Provide a minimum of one drinking fountain with filtered water and bottle refill station on every occupied level of the building.
  2. Water coolers shall provide a minimum of 8 gallons per hour chilling capacity.

**D2020 Domestic Water Distribution****D2021/2022 Cold/Hot Water Service**

- A. Domestic Water Piping
  1. Copper type 'L', hard drawn
    1. Soldered joints.
    2. "ProPress" or equivalent joints may be used with prior written approval.
    3. Piping extending from walls for fixture connections shall be rigidly braced to prevent movement during and after fixture installation.
    4. Plastic clamps and flat support brackets are not permitted.
  2. Pex-A
    1. Permitted for pipe sizes  $\leq 2$ ".
    2. Straight sticks only.
    3. Cannot be used for risers.
    4. Changes in direction shall be made using manufacturer's approved fittings.
    5. Transitions to copper using manufacturer's approved fittings.
    6. Install in a neat workmanlike manner, free from unnecessary traps, sags, or air pockets.
    7. Piping passing through walls, floors, or other structural elements shall be sleeved.
- B. Domestic Water Pipe Cleaning/Disinfection
  1. [Domestic Water Line Cleaning and Disinfecting Requirements](#)
- C. Stud guards required if pipe is within 1½" of face of wall.

D2023 Domestic Water Supply Equipment

- A. Plumbing Pumps
  - 1. Package booster pumping station to be duplex type, utilize variable speed drive pumps when applicable.
- B. Washing machine and ice maker boxes should be metal commercial grade, not plastic.
- C. Any serviceable or replaceable plumbing appurtenances shall be accessible.

D2024 Insulation and Identification

A. Piping Insulation - Type & Thickness

Service	Type	Up to 1 ¼”	≥ 1 ½”
Domestic Hot Water	Fiberglass	1”	1.5”
Domestic Cold Water	Fiberglass	.75”	1”

- 1. End joints of pipe insulation shall be sealed to pipe.

D2025 Specialties

- A. Backflow Preventers
  - 1. Domestic and Fire Water
    - 1. Install in mechanical room.
  - 2. Provide a bypass with check valve and lockable ball valve if single backflow preventer is provided.
  - 3. If reduced pressure type (RPZ), provide drain funnel and pipe to floor drain.
  - 4. Irrigation Water
    - 1. Install in pit in yard with separate water meter.
  - 5. See Section G30 for additional requirements.
  - 6. Backflow Preventer detail.
    - 1. [Interior Backflow Preventer](#)
    - 2. [Exterior Backflow Preventer](#)
- B. Dielectric Union
  - 1. Provide ball valves on each side of dielectric union.
- C. Recirculation Pump
  - 1. Provide ball valves on each side of recirculation pumps.
- D. Shock Arrestors
  - 1. Show locations on as-built drawings.

D2030 Sanitary Waste

- A. All 4” and greater below grade Sanitary/Grease/Acid Sewer Pipe to have video inspection and approval prior to covering.
  - 1. [Inspection Requirements for New Below Grade Sanitary/Storm/Grease/Acid Sewer Pipe](#)

## D2031 Waste Pipe

- A. Piping Below Grade:
  - 1. Cast iron hub and spigot. For connections to existing piping, standard flexible couplings are preferred.
  - 2. Do not use a shielded (no-hub) coupling below grade.
  - 3. Connections to existing piping are to use the Stainless Steel 4 band clamp coupling.
  - 4. Document pipe locations with GPS by AU Utility Locate Team.
- B. Piping Above Grade:
  - 1. Cast iron no-hub with four band mechanical clamps. Husky Heavy Duty or equivalent.
  - 2. [Pipe Labels](#)
- C. Epoxy lined CI to be used in caustic environments.
- D. Cleanouts:
  - 1. Wall cleanouts shall be flush with finished wall.
  - 2. Cleanouts are to be accessible. Provide access panel in hard ceilings as required.
  - 3. Locate to the side of the Water Closets with a minimum clearance of 6” from the rough-in of the Water Closets. Preferred location is in ADA stall to allow for additional access.
  - 4. Wall cleanouts shall be located between 30” and 42” above finished floor.
  - 5. Wall cleanouts shall be connected to main line with a sweep connector.
  - 6. Provide location of cleanouts and test plugs on as-built drawings.
- E. Lavatory P-traps
  - 1. 17-gauge brass with integral cleanout.
  - 2. Traps shall have mechanical connection (not soldered) at wall connection to allow for removal and use as a cleanout.
- F. All overhead P-traps shall have trapeze hanger with U-bolt clamp for support.
- G. Maximum depth of a P-trap weir from finished floor is 24”.
- H. Indirect Drains
  - 1. Copper type ‘M’ for 1” and smaller, type ‘DWV’ for 1¼” and larger with sweat joints.

## D2032 Vent Pipe

- A. Piping below grade:
  - 1. Cast iron hub and spigot. For connections to existing piping, standard flexible couplings are preferred.
  - 2. Do not use a shielded (no-hub) coupling below grade.
  - 3. Document locations with GPS.
- B. Piping above grade:
  - 1. Cast iron no-hub with four band mechanical clamps. Husky Heavy Duty or equivalent.

**D2033 Floor Drains**

- A. Minimum size: 3” outlet.
- B. Provide floor drains in Water Closets, Shower Rooms, Kitchens, Food Service, Break Rooms, and Mechanical Rooms.
- C. Provide floor drains for all emergency/drench showers.
- D. Provide trap primers for all floor drains, trench drains, hub drains, floor sinks, and shower drains. All trap primers shall have isolation valves. Access panels shall be provided if trap primer is located behind a wall or above a ceiling.
- E. Floor must slope to drain.
  - 1. [Floor Drain Detail](#)

**D2034 Sanitary Waste Equipment**

- A. Sewage ejectors to be used only with prior approval from University Project Manager.

**D2040 Rainwater Drainage****D2041 Pipe and Fittings**

- A. Above Grade:
  - 1. Cast iron no-hub with four band mechanical clamps. Husky Heavy Duty or equivalent.
- B. Below Grade:
  - 1. Cast iron hub and spigot.
  - 2. For connections to existing infrastructure, standard flexible couplings are preferred.
  - 3. Document locations of couplings with GPS.
  - 4. Do not use a shielded (no-hub) coupling below grade.

**D2090 Other Plumbing Systems****D2091 Gas Systems**

- A. Medical Gases: All medical gas pipe, fittings, and equipment shall be cleaned and capped and installed in accordance with NFPA99.
  - 1. Oxygen
    - 1. Copper tubing type ‘K’ or ‘L’, less than ½” soft annealed, ½” to 1.5” hard drawn.
  - 2. Argon
    - 1. Copper tubing type ‘K’ or ‘L’, less than ½” soft annealed, ½” to 1.5” hard drawn.
  - 3. Carbon Dioxide
    - 1. Copper tubing type ‘K’ or ‘L’, less than ½” soft annealed, ½” to 1.5” hard drawn.
  - 4. Helium

1. Copper tubing type 'K' or 'L', less than ½" soft annealed, ½" to 1.5" hard drawn.
  5. Nitrogen
    1. Copper tubing type 'K' or 'L', less than ½" soft annealed, ½" to 1.5" hard drawn.
  6. Nitrous Oxide
    1. Copper tubing type 'K' or 'L', less than ½" soft annealed, ½" to 1.5" hard drawn.
  7. Acetylene
    1. Stainless steel type 316 with Swagelok fittings.
  8. Hydrogen
    1. Stainless steel type 316 with Swagelok fittings.
- B. All Medical Gas systems must be pressure tested in accordance with NFPA 99.
- C. Regulators should be tagged and charted on as-builts.

#### D2092 Acid Waste Systems

- A. Lab Acid Waste and Vent Piping
1. Above grade
    1. Polypropylene with mechanical joints.
  2. Below grade
    1. Polypropylene with thermal fusion joints.
  3. All overhead P-traps shall have trapeze hanger with U-bolt clamp for support.

#### D2099 Other Piping Systems

- A. Compressed Air Systems
1. Air Compressors
    1. Duplex type, 100% capacity each compressor, with ASME stamped receiver.
  2. Compressed Air Piping
    1. Copper tubing type 'K' or 'L'.
      1. Less than ½" soft annealed.
      2. ½" to 1.5" hard drawn.
      3. Greater than 1.5" schedule 40 black steel.
    3. Sediment trap required prior to equipment connections.
- B. Vacuum Systems
1. Vacuum Pumps
    1. Duplex type, 100% capacity each pump.
  2. Vacuum Piping
    1. Copper tubing type 'K' or 'L'.
      1. Less than ½" soft annealed.
      2. ½" to 1.5" hard drawn.
- C. Processed Water Systems
1. Deionized Water Piping
    1. Polyvinylidene fluoride (pvdf) Kynar resin SDR 11-21 with thermal fusion joints.

2. Distilled Water Piping
  1. Perfluoroalkoxy pipe (PFA) Teflon schedule 40 or 80 with thermal fusion, mechanical, or threaded joints.
3. Reverse Osmosis Water Piping
  1. Polyvinylidene fluoride (pvdf) Kynar resin SDR 11-21 with thermal fusion joints.

## **D30 Heating, Ventilation & Air Conditioning (HVAC)**

### **D3010 Energy Supply**

#### D3012 Gas Supply System

- A. Liquid Petroleum (LP) and Natural Gas Piping:
  1. Below grade:
    1. High density polyethylene (HDPE) with electro/heat fusion joints.
    2. HDPE piping shall be installed per 49CFR Part 192 by a certified installer.
    3. Install with a #12 AWG copper tracer wire.
  2. Above grade:
    1. Black steel, schedule 40.
    2. Gas train to be painted battleship gray.
  3. Sediment trap required prior to all equipment.
  4. [Gas Train Detail](#)

### **D3020 Heat Generating Systems**

#### D3021 Boilers

- A. Boilers and Pressure Vessels
  1. Shall be designed, constructed, installed, operated, maintained, and inspected in accordance with Alabama Boiler and Pressure Vessel Safety Act.
  2. Permits for new or relocated units shall be included in project costs. Permits shall be obtained and maintained by General Contractor throughout warranty period.
  3. Provide emergency shutdown button switch (mushroom type) located at mechanical room entrance for each boiler.
  4. Boiler Boil Out
    1. [Boiler Boil Out](#)
  5. Boiler Water Treatment
    1. [Boiler Water Treatment General Guidelines](#)

### **D3030 Cooling Generating Systems**

#### D3032 Direct Expansion Systems

- A. Refrigerant Piping – Copper Tubing, Type “ACR”.

**D3040 Distribution Systems**

## D3041 Air Distribution Systems

## A. Air Handling Units

1. Custom air handlers shall not be specified without prior written approval by the University Project Manager.
2. Preferred System: VAV air handling with hot water reheat.
3. Units shall be double wall construction.
4. Test ports for each section shall be factory mounted.
5. Sensors and devices that are located on air handling units to be factory mounted when possible.
6. Access doors to be person-sized and thermally broken. Installed between coils, at filters and fans.
7. HVAC Equipment (AHU's, pumps, etc.) shall be located on a housekeeping pad.
8. Fan coil units shall not be located above a ceiling.
9. All equipment shall be field inspected and tested by the manufacturer or a factory-trained authorized representative for installation in compliance with the manufacturer's installation instructions and recommendations prior to start-up. The manufacturer or a factory trained authorized representative shall perform, or be present at, the start-up. Start-up documentation certifying proper installation and start-up shall be submitted to University Project Manager at that time and shall also be included in the O&M manuals.
10. HVAC systems shall not be started until cleaning, flushing, and pre-treatment has been performed to the satisfaction of the University Project Manager.
11. Following start-up procedures, adjust equipment for proper operation within manufacturer's published guidelines and tolerances. Demonstrate proper operation of equipment and systems to designated University Project Manager and the Commissioning Agent.

## B. Filters

1. Type A frames required.
2. In mechanically ventilated buildings, provide regularly occupied areas of the building with air filtration media that provides a Minimum Efficiency Reporting Value (MERV) of 13 or better.
3. 100% outside air units should have MERV-8 filtration.
4. If permanently installed air handlers are used during construction, in addition to the specified unit filters, filtration media with a Minimum Efficiency Reporting Value (MERV) of 8 shall be used at each return air grille, return duct inlet, outside air inlet, and intake louvers. Replace all filtration media one week prior to Substantial Completion.

## C. Fans

1. Units over 5000 cfm to have a fan array with minimum of two fans.
  1. Each fan shall have an independent barometric isolation damper.
  2. Each Fan Status to be monitored on BAS.
2. Maximum of two VFD's per AHU.

- D. Motors
  - 1. Inverter Rated
    - 1. Motors for equipment served by variable speed drives shall be Inverter-rated motors conforming to NEMA MG-1, Part 3, 1.15 service factor, class “F” insulation, and grounding rings.
    - 2. Maximum RPM: 1750 without prior approval.
    - 3. Motors 5 hp or larger shall have VFD.
  - 2. ECM
    - 1. Must integrate with building BAS
    - 2. 1750 RPM maximum
    - 3. 10 hp maximum
- E. Variable Frequency Drives (VFD)
  - 1. Mount on wall at 48” AFF in NEMA 12 enclosure.
  - 2. Mounting on equipment only acceptable when factory installed.
  - 3. Provide with a serial interface to allow bi-directional communication with the existing controls system.
  - 4. At a minimum, the following points shall be made available to the controls system: Set Point, Drive Speed (RPM), Frequency (Hz), Current (A), Power (KW), Energy (KWH), Last Fault Number, OK/Faulted Status, Stop/Run Status, and Hand/Off/Auto Status.
  - 5. No bypass required.
  - 6. Provide a lockable service disconnect immediately upstream and adjacent to the VFD.
  - 7. The preferred drive manufacturer shall be Danfoss or approved equal.
- F. Coils
  - 1. Chilled Water Coil Selection:
    - 1. Water Supply Temperature: 42°F
    - 2. Water Delta T: 15°F
  - 2. Units with stacked coils shall have balancing valves for each coil and coil tracks for coil removal.
  - 3. Reheat Coil
    - 1. Access door/panel shall be provided upstream and downstream of re-heat coils.
    - 2. Provide pressure independent balancing valves at reheat coils.
  - 4. Avoid sandwiched coils.
  - 5. Pressure gauges and thermometers to be provided on supply and return piping.
    - 1. Pressure gauges to be provided with gauge valve.
    - 2. Thermometers to be provided with thermometer well.
  - 6. P-T Plugs (Pete’s Plugs) shall be provided adjacent to all control sensors for testing and verification.
  - 7. Locate isolation valves outside the coil pull line to allow coil removal without disruption of hydronic service to other equipment and to keep piping disassembly to a minimum.
  - 8. UV lights to be provided downstream of cooling coil.

- G. Drain Pans
  - 1. Internal pans to be stainless steel construction.
  - 2. Intermediate drain pans shall be installed on multiple coil sections.
  - 3. Auxiliary drain pans with water level switch required on all units. Sensor shall be connected to the control system.
- H. Dampers
  - 1. Outside air dampers shall be stainless steel or aluminum.
- I. Gauges, meters, thermometers, etc., shall be accessible and readable from floor level.
- J. Condensate Water Piping:
  - 1. 4" and Less: Copper Type "L" or Stainless Steel
  - 2. 5" and Larger: Black Steel, Schedule 40
- K. VAV/Terminal Units
  - 1. Controllers, actuators, dampers, and valves shall be easily accessible and located in hallways or at the space entry with a minimum 2' x 2' opening.
  - 2. Provide bottom access door on all terminal units.
  - 3. Label units to reflect location and AHU.
    - 1. TU-Floor#-AHU#-Unique#
  - 4. No serviceable devices to be located above a hard ceiling unless an access door is provided.
  - 5. Provide access and required clearances (per NEC) and requirement for coordination between trades.
  - 6. VAV Coil connections should have a hanger within 12" of coil.
  - 7. Provide VAV label on ceiling grid to identify VAV location.
- L. Duct
  - 1. Fibrous Glass Duct:
    - 1. Fibrous glass duct (or duct board) is not allowed.
  - 2. Flexible Duct:
    - 1. Runouts to diffusers shall be limited to 5 feet.
    - 2. Takeoffs for flexible ducts shall be installed at main duct branch.
  - 3. Metal Duct:
    - 1. Design and construction shall comply with SMACNA standards.
    - 2. Specialty ductwork materials (i.e., stainless steel, aluminum, etc.) or construction shall be clearly noted and hatched on the plans.
  - 4. Underground ductwork is not acceptable.
  - 5. During construction all open ducts shall be sealed.
  - 6. Duct sealant/mastic shall be installed at all duct joints and terminations of flexible ducts to seal leaks.
  - 7. Provide access panels in duct for all devices (dampers, actuators, etc.).
- M. Insulation
  - 1. No internal duct liner allowed.
  - 2. Provide externally wrapped fiberglass insulation or factory fabricated double wall duct with perforated metal liner.
  - 3. All duct work with the possibility of condensation shall be insulated.
  - 4. Insulation support pins shall be welded to ductwork. Glue-on/stick-on pins are not acceptable.

- N. Outside air intake louvers should have access doors or be fully hinged for cleaning bird screen.
- O. Diffusers/Registers/Grilles
  - 1. Shall be of corrosion resistant construction of aluminum or stainless steel.
  - 2. All items visible through return air grilles shall be painted flat black.

#### D3042 Exhaust Ventilation Systems

- A. Provide mechanical ventilation in attic spaces.
- B. Locate all maintenance parts (belts, motors, bearings, etc.) outside of contaminated air stream.
- C. Laboratory exhaust systems shall be designed in accordance with NFPA 45.
- D. Fume hood and kitchen exhaust ducts to be continuously welded, watertight.
- E. Welded longitudinal joints to be facing up.
- F. Fans shall have an upblast discharge if possible.

#### D3043 Steam Distribution Systems

- A. Below Grade Piping
  - 1. Steam Piping
    - 1. ASTM A106-B, Seamless, Grade B, Schedule 40 / Schedule 80
    - 2. Complete factory-fabricated steam piping system with carrier pipes.
    - 3. Joints:
      - 1. Trenches - Butt-weld joints. Socket weld is required for pipe sizes 50 mm (2") and less.
      - 2. Vaults - Butt weld pipe sizes 65 mm (2½") and greater; thread or socket weld pipe sized 50 mm (2") and less. Use Schedule 80 pipe and forged steel fittings for threaded joints.
    - 4. Valves – 2½" or greater - Gate valves, Steel body rated to 150 psig at 500° F.
  - 2. Condensate Piping
    - 1. ASTM A106-B, Seamless, Grade B, Schedule 80.
    - 2. Complete factory-fabricated condensate piping system with carrier pipes.
    - 3. Joints:
      - 1. Trenches - Butt-weld joints. Socket weld is required for pipe sizes 50 mm (2") and less.
      - 2. Vaults - Butt weld pipe sizes 65 mm (2½") and greater. Socket weld pipe sizes 25 mm (1") and greater, and thread pipe sizes less than 25 mm (1"). Use Schedule 80 pipe and forged steel fittings for threaded joints.
    - 4. Valves - 2½" or greater – Gate valves, Forged steel body rated to 300 psig at 420° F.
- B. Above Grade Piping:
  - 1. Steam – Black Steel, Schedule 40
  - 2. Steam Condensate – Black Steel, Schedule 80
  - 3. Insulation
    - 1. Fiberglass

2. End joints of pipe insulation shall be sealed to pipe.
  3. All elbows and fittings to be fully insulated.
  4. Pipe Labels
    1. [Pipe Labels](#)
  5. All valves, including balancing valves, to be tagged with brass tags. Provide a chart noting all valve locations along with identifier, type, and location on as-built drawings.
- C. Steam Condensate Receiver: Duplex type

#### D3044 Hot Water Distribution

- A. Primary Hot Water Decoupled at building.
1. Primary Hot Water Supply Temperature: 180° F
  2. Primary Hot Water HX Delta T: 30° F
  3. Primary Hot Water Excursion to 250° F
  4. Hot Water Heat Exchanger
    1. Should have capacity to install additional plates to increase 20% additional capacity.
    2. Pressure Drop: Not to exceed 15 feet at double the design flow rate.
- B. Locate main piping runs above corridors when possible.
- C. Mechanically formed (pulled) Ts are acceptable for ½” and ¾” piping connections to 2” or larger pipe.
- D. Minimize quantity of dielectric unions. Unions shall be in accessible locations for ease of maintenance. Provide ball valves on each side of union to allow for repair of union.
- E. System shall be cycled through heat up and cool down and checked for leaks prior to substantial completion.
- F. Piping
1. Below Grade
    1. Black Steel Pre-Insulated Pipe Conduit
      1. ASTM A-53 Grade B, Schedule 40
      2. Use standard pipe sizes.
      3. Insulation:
        1. Polyurethane Foam
      4. Outer Jacket:
        1. Extruded black HDPE
        2. Wall Thickness
          1. 100 mills for pipe ≤ 12”Ø
          2. 125 mills for pipe > 12”Ø
    2. Cross-linked polyethylene, Type A (PE-Xa)
      1. Rated for continuous operating temperature of 210°F at 80psi.
      2. Fittings/Joints to be mechanical or electrofusion rated for below-grade applications.
      3. Insulation: Closed Cell Spray Foam, Field Applied.
      4. Minimum 40 yr manufacturer warranty.

2. Above Grade
    1. 4" and less: Copper Type "L" or Stainless Steel
    2. 5" and larger: Black Steel, Schedule 40
    3. Insulation
      1. Fiberglass
      2. Outer Jacket: ASJ
      3. End joints of pipe insulation shall be sealed to pipe.
      4. All elbows and fittings to be fully insulated.
  3. Pipe Labels
    1. [Pipe Labels](#)
  4. All valves to be tagged. Provide as-built drawings and a tag chart noting location of valves.
- G. Make-up Water Piping
1. Copper Type "L".
  2. Provide separate water meter.
  3. Provide RPZ back-flow preventer.
- H. Valves
1. Provide isolation of each independent item of equipment.
  2. Provide isolation at each branch takeoff.
  3. Valves located on Primary water supply and return shall be offset butterfly type with metal seats.
  4. All valves to be tagged. Provide a chart noting valve location along with as-built drawings.
- I. Pumps
1. Base mounted vertical centrifugal.
  2. Provide and install two 100% capacity pumps for redundancy.
  3. Horizontal split case pumps are acceptable for larger capacity requirements.
- J. Motors
1. Motors for equipment served by variable speed drives shall be Inverter-rated motors conforming to NEMA MG-1, Part 3, 1.15 service factor and class "F" insulation.
  2. Maximum RPM: 1750 without prior approval.
  3. Motors 5 hp or larger shall have VFD.
- K. Variable Frequency Drives (VFD)
1. Mount on wall at 48" AFF in NEMA 12 enclosure.
  2. Provide with a serial interface to allow bi-directional communication with the existing controls system.
  3. At a minimum, the following points shall be made available to the controls system: Set Point, Drive Speed (RPM), Frequency (Hz), Current (A), Power (KW), Energy (KWH), Last Fault Number, OK/Faulted Status, Stop/Run Status, and Hand/Off/Auto Status.
  4. No bypass required.
  5. Provide a lockable service disconnect immediately upstream and adjacent to the VFD.
  6. The preferred drive manufacturer shall be Danfoss or approved equal.

- L. Expansion Tanks
  - 1. Label tanks with installed pressure settings as determined by TAB.

#### D3045 Chilled Water Distribution

- A. Locate main piping runs above corridors when possible.
- B. Mechanically formed (pulled) T's are acceptable for ½" and ¾" piping connections to 2" or larger pipe.
- C. Minimize quantity of dielectric unions. Unions shall be located in accessible locations for ease of maintenance. Provide ball valves on each side of the union to allow for repair of union.
- D. Piping
  - 1. Below Grade:
    - 1. Cement Lined Ductile Iron Pipe
      - 1. Class 50 or 51
      - 2. Use standard Pipe sizes
      - 3. Restrained Mechanical Joints
      - 4. Insulation
        - 1. Closed Cell Polyurethane (90%-95%) with minimum K-Factor of .18
      - 5. Outer Jacket
        - 1. Extruded Black HDPE
        - 2. Wall Thickness
          - 1. 100 mills for pipe ≤ 12"Ø
          - 2. 125 mills for pipe > 12"Ø
      - 6. Fittings
        - 1. Cement Lined and Asphalt Coated to match pipe.
        - 2. Field insulated Urethane Foam or approved equal
        - 3. PVC Jacket with Asphalt Wrap
    - 2. HDPE
      - 1. PE4710 Material conforming to ASTM F714, DR11 (IPS)
      - 2. Thermal butt fusion per ASTM F2620
  - 2. Above Grade:
    - 1. 4" and Less: Copper Type "L" or Stainless Steel
    - 2. 5" and Larger: Black Steel, Schedule 40
    - 3. Insulation: Cellular Glass
    - 4. Outer Jacket: ASJ
    - 5. Pipe Labels
      - 1. [Pipe Labels](#)
- E. Valves
  - 1. Provide isolation of each independent item of equipment.
  - 2. Provide isolation at each branch takeoff.
  - 3. Valves located on Primary water supply and return shall be offset butterfly type with metal seats.

4. All valves, including balancing valves, to be tagged with brass tags. Provide a chart noting all valve locations along with identifier, type, and location on as-built drawings.

F. Pumps

1. Base mounted vertical centrifugal.
2. Provide and install two 100% capacity pumps for redundancy.
3. Horizontal split case pumps are acceptable for larger capacity requirements.

G. Expansion Tanks

1. Label tanks with installed pressure settings as determined by TAB.

D3046 Hydronic Distribution Cleaning and Treatment

A. Closed Loop Cleaning – Existing Construction

1. [Closed Loop Hydronic Distribution Cleaning – Existing Construction](#)

B. Closed Loop Cleaning – New Construction

1. [Closed Loop Hydronic Distribution Cleaning – New Construction](#)

C. Evaporative Cooling - General Guidelines

1. [Evaporative Cooling - General Guidelines](#)

D. Evaporative Cooling Systems Cleaning/Treatment

1. [Evaporative Cooling Systems Cleaning/Treatment](#)

D3060 Controls and Instrumentation

B. General

1. HVAC Design Criteria
  1. Outdoor Design Conditions

Winter	24°F DB
Summer – Cooling	93°F DB / 74°F MCWB
Summer - Evaporation	77°F DB / 87°F MCWB
Summer – Dehumidification	75°F DB / 134 HR / 81°F MCDB
Degree Days Heating	2383 (Base 65°F)
Degree Days Cooling	1859 (Base 65°F)
Climate Zone	3A

2. Indoor Design Conditions

Winter	68°F DB
Summer – Cooling	72°F DB / 50% RH
Summer - Evaporation	77°F DB / 87°F MCWB
Max Space Humidity	60% RH

## D3061 Heating Generating Systems

- A. Control schemes for all building hot water hydronic systems:
  - 1. Secondary hot water differential pressure set point reset.
    - 1. Setpoint shall not reach high limit based on a single feedback.
    - 2. Devices serving the following areas should not be included in this control logic:
      - 1. Mechanical rooms, custodial rooms, stairways, corridors.
  - 2. Secondary hot water temperature reset.
    - 1. Maximum Temperature – 160°F
  - 3. Hot water pump rotation
    - 1. P-1; 1st to 15th of the month, P-2; 16th to end of month.

## D3062 Cooling Generating Systems

- A. Control schemes for all building chill water hydronic systems:
  - 1. Building chilled water differential pressure set point reset.
    - 1. Setpoint shall not reach high limit based on a single feedback.
    - 2. Devices serving the following areas should not be included in this control logic:
      - 1. Mechanical rooms, custodial rooms, stairways, corridors.
  - 2. Rooms requiring temperature control to protect equipment (AV, Electrical, Server) should be designed to minimize energy consumption while providing equipment protection.
  - 3. Secondary chilled water pump to be put to sleep when building  $\Delta P$  is greater than  $\Delta P$  setpoint.
  - 4. Chilled water pump rotation.
    - 1. P-1; 1st to 15th of the month, P-2; 16th to end of month.

## D3063 Heating/Cooling Air Handling Units

- A. Unoccupied set points shall include reduced airflow set point and temperature set point:
  - 1. Cooling: 82°F
  - 2. Heating: 63°F
  - 3. Air Flow: Lower of 10% of max or minimum flow.
- B. The following control schemes shall be implemented for all air handling units:
  - 1. Discharge air temperature reset.
    - 1. Setpoint shall not reach low limit based on a single feedback.
    - 2. Devices serving the following areas should not be included in this control logic.
      - 3. Mechanical rooms, custodial rooms, stairways, corridors, bathrooms.
  - 2. Static pressure reset.
  - 3. Economizer mode.
    - 1. Reduce the outside airflow set point when zone CO<sub>2</sub> levels are low and motion sensors detect no occupancy.
- C. Air Measurement Devices

1. Provide a measurement device with an accuracy of plus or minus 15% of the design minimum outdoor air rate for mechanical systems that utilize direct measurement of outdoor air.
- D. CO<sub>2</sub> Monitors
  1. Provide CO<sub>2</sub> monitors within all densely occupied spaces (greater than 25 people per 1000 SF) served by the air handling unit that measures outside air.
  2. Locate monitors between 3 and 6 feet above the floor.
  3. Monitors shall communicate with the building automation system to provide an alarm when carbon dioxide is out of range for the space.
  4. Provide a way to locally adjust controls in all auditoriums.
- E. Temperature sensors shall be nickel construction.
- F. Control relays shall be installed in control panels, starters, or variable speed drive.
- G. Control thermostat/sensor boxes in walls shall be sealed/ caulked to prevent airflow through the device.
- H. Monitor individual fan status on units with multiple fans.

#### D3066 Terminal Devices

- A. Connect terminal units with room lighting occupancy sensors via an additional set of contacts on the motion sensor and hardwired into the VAV binary input to enable terminal unit occupancy mode.
- B. During normal hours when occupancy is not detected by sensor setpoint, control will reset to +/- 4°F.
- C. During unoccupied mode, sensor will automatically enable occupied mode for 1 hour (adjustable).

#### D3067 Energy Monitoring and Control

- A. Setback Schedules
  1. Should be determined after building use discussion with the building occupants.
  2. All setback schedules are to be programmed at substantial completion.
  3. The following standards are to be used as a starting point for setback schedules.
    1. Admin (offices, conference rooms, copy rooms, break rooms, etc.)
      1. Occupied – 6:45 am
      2. Unoccupied – 5:15 pm
      3. Unoccupied on University holidays.
    2. Classroom (Provide override ability via room thermostat or integrated room occupancy sensor.)
      1. Occupied – 1 hour prior to start of 1st class in the building.
      2. Unoccupied – 30 minutes after end of last class in the building.
      3. Unoccupied on University holidays.
    3. Computer Lab
      1. Same as classroom.
    4. Teaching Laboratory
      1. Same as classroom.

5. Research Laboratory
    1. Equal to the greater of either admin or classroom schedules in that building.
    2. Holidays – Same as admin or classroom schedules.
  6. Studio
    1. Occupied – 7:30 am
    2. Unoccupied – 11:00 pm
    3. Holidays – Unoccupied all student breaks and University holidays.
  7. Dorms
    1. Occupied - 24/7
    2. Unoccupied – Extended student breaks.
- B. Control Points
1. Control Points shall be ordered such that set points are grouped with associated controlling points.
  2. User views will be constructed so points are organized the same for like systems.
  3. Building Management System (BMS) Point Naming Convention & Trends
    1. [Controls Standard Naming Convention](#)
  4. System/Equipment Control Schemes.
    1. Typical VAV Terminal Box
      1. [VAV Terminal](#)
    2. Typical Variable Volume Air Handler with Economizer
      1. [VAV AHU w Econ](#)
    3. Typical Energy Recovery Air Handler
      1. [Energy Recovery AHU](#)
    4. Typical Single Zone Air Handler with Economizer
      1. [Single Zone AHU w Econ](#)
    5. Fan Coil Unit
      1. [Fan Coil Unit Control Diagram](#)
    6. Chilled Water Interface
      1. [Chill Water Building Connection](#)
    7. Hot Water Interface
      1. [Hot Water Building Connection](#)
  5. Emergency Equipment Control Points
    1. Emergency generator status.
    2. Automatic transfer switch, switch position.
- C. Alarm Points
1. The Designer of Record shall submit an alarm table summarizing the alarms to be configured for the project and their associated set points.
  2. Alarms shall be designed to communicate out to remote monitoring and notification system during the event of a power outage.
  3. Standard Alarms for required systems.
    1. [Alarm List](#)
  4. Non-standard alarms configured during construction and commissioning are to be removed prior to turnover.

**D3068 Building Automation Systems**

1. Johnson Controls Inc.'s Metasys Extended Architecture is the standard interface for building management systems.

**D3069 Other Controls & Instrumentation****A. Wiring, Conduit, Power**

1. All wiring and conduit shall be installed as a complete and independent system. All control power and control wiring shall be labeled at each end and at any spliced joint.
2. Control submittals shall include wiring diagrams for each system or piece of equipment.
3. Control Wiring
  1. Control wiring in exposed ceilings to be in conduit
  2. Control wiring located above accessible ceilings to be plenum rated cable installed in cable trays or J-hooks run perpendicular or parallel to building lines.
4. All controls conduit, boxes, and covers shall be painted white in color.
5. Exposed conduit within open ceilings may be painted room color. Inside of each j-box and cover to be painted the corresponding box and conduit color.
6. Label all junction box covers with: "HVAC CONTROLS"
7. Power Requirements
  1. All DDC control panels shall be served by a dedicated circuit fed directly from the panel board.
  2. All network panels and DDC control panels that serve equipment on emergency power shall be provided with an uninterruptable power supply sized to provide sufficient time for transition to emergency power or equipment shutdown and alarm notification.

**D3070 Systems Testing and Balancing****A. Test & Balance (T&B)**

1. Test and balance of the air and water side of an HVAC system shall be performed for any equipment replacement and/or system modifications.
2. Test and balance shall be performed by an Associated Air Balance Council (AABC) or National Environmental Balancing Bureau (NEBB) certified T&B Contractor that shall be a different company than the mechanical Contractor and approved by the University Project Manager.
3. Testing and balancing of HVAC systems shall be performed, at minimum, in accordance with AABC or NEBB National Standards.
4. Final T&B report shall include design and actual readings with explanation and recommendation for remediation for readings that could not be balanced.
5. The schedule for T&B shall be incorporated in the overall project schedule such that T&B shall be complete prior to substantial completion.

**D3073 HVAC Commissioning**

- A. Commissioning shall be provided for both air and water side of the HVAC System at a minimum.
- B. Commissioning Authority shall be contracted directly with the Owner.
- C. Agreement between Owner, Designer of Record and General Contractor will define roles and relationships between Designer of Record and General Contractor and the Commissioning Authority.
- D. The schedule requirements for the commissioning process shall be incorporated in the overall project schedule such that commissioning process shall be complete prior to substantial completion.
- E. The scope of commissioning services will be defined during the design phase of the project.
- F. General Contractors shall be responsible for the initial controls testing prior to commissioning by Auburn University. All aspects of the system shall be functionally correct prior to commissioning.
- G. Commissioning will be jointly performed by Auburn University, Contractor(s), BAS Contractor, Construction Administration Engineer, and Commissioning Agent.
- H. Connection to continuous monitoring system shall be provided as soon as BAS is on the AU network and funded by project.
- I. [Commissioning \(Cx\) Decision Matrix](#)

**D40 Fire Protection****D4010 Sprinklers****D4011 Sprinklers Water Supply Fire Suppression**

- A. Provide fire sprinkler system in accordance with NFPA 13.
- B. Piping and hangers shall be free from direct contact with other trades.
- C. Provide an exterior weatherproof horn/strobe fire alarm device immediately adjacent to fire riser room such that it will be visible to first responders.
- D. Piping:
  - 1. Below Grade
    - 1. Cement lined ductile iron with mechanical joints.
  - 2. Wet System Above Grade
    - 1. 2" and smaller: Black steel schedule 40 with screwed joints.
    - 2. 2.5" and larger: Black steel schedule 10 with grooved mechanical joints (Victaulic).
- E. Provide hydrostatic calculation plate for each fire riser.
- F. Backflow Preventer
  - 1. Locate in fire riser room in building.
- G. Valves
  - 1. Post indicator valves shall be equipped with tamper switches and locks.

2. Padlocks shall be Auburn University locks obtained from Facilities Access Control. These locks are keyed specifically for sprinkler system locks (i.e. 100E).
- H. Fire Department Connection: Provide locking caps compatible with City of Auburn Fire Division.

## **D4030 Fire Protection Specialties**

### **D4031 Fire Extinguishing Devices**

- A. Before renovation, alteration, or demolition, the General Contractor shall contact the University Project Manager and arrange to have all existing fire extinguishers delivered to an acceptable storage facility to be reused in other University facilities.
- B. Fire Extinguishers
  1. All facilities shall be provided with 10 lb. ABC multi-purpose dry chemical portable fire extinguishers along with other types and sizes as required.
  2. Extinguishers in public areas shall be mounted in recessed or semi-recessed cabinets capable of holding the extinguisher without the use of hooks or brackets.
  3. Cabinet doors should be equipped with a roller ball or magnetic latch.
  4. All portable extinguishers shall be in visible locations and free from obstructions. Signage shall be provided to indicate the extinguisher location where visual obstructions cannot be avoided.
  5. All rooms, classified as laboratory by Auburn University Space Management standards, shall be provided with a minimum 5 lb. ABC multi-purpose dry chemical portable fire extinguisher.

## **D50 Electrical**

### **D5010 Electrical Service and Distribution**

#### **D5012 Low Tension Service & Distribution**

- A. Distribution Equipment
  1. Approved secondary distribution equipment manufacturers:
    1. Square D (Schneider)
    2. General Electric (ABB)
    3. Siemens
    4. Cutler Hammer (Eaton)
  2. All main breakers shall be equipped with lockout/tagout frames to allow the breaker to be locked in the open position.
  3. All main distribution equipment shall be supplied with remote mounted Transient Voltage Surge Suppressor.
  4. Circuit breakers shall be bolt-in type; plug-in/snap-in type not permitted.
  5. "Piggyback" style and combination circuit breakers are not permitted.
  6. All distribution equipment bussing shall be copper.

7. Service entrance conductors to be copper XHHW.
  8. Panelboard directories shall be type-written.
  9. Panelboard covers shall be “door-in-door” type.
  10. Floor mounted equipment shall be installed on a 3.5” high concrete housekeeping pad that extends 3” out from base of equipment on all sides.
  11. The location of all exterior electrical equipment shall be approved by the University Project Manager.
  12. Provide TVSS units in remote enclosures. Serve TVSS units from circuit breaker in main panels.
- B. Conduit & Raceways
1. Below Grade:
    1. Schedule 80 PVC if direct buried.
    2. Schedule 40 PVC if encased in or under concrete.
  2. The transition from PVC or HDPE to Rigid IMC or GSP shall be made with threaded 90° long radius bends at stub up locations. Threaded ground bushings shall be used where applicable. Rigid pipe shall be treated with UL Listed corrosion resistant tape to protect against rust.
  3. Minimum depth of bury shall be three feet.
  4. Minimum conduit size to be ¾”.
  5. Rigid Metal Conduit (RMC) to be used (indoors/outdoors) where exposed to direct physical damage. RMC to be used in parking decks.
  6. Electrical Metallic Tubing (EMT) to be used (indoors only) in concealed/protected areas not subject to physical damage.
  7. Liquid tight flexible metal conduit to be used for final connection to fan/pump motors or vibrating loads.
  8. Conduit to be concealed in all public areas. Exposed conduit only permitted in mechanical, electrical, and telecom rooms or other locations approved by University Project Manager.
  9. Chatter Clips shall be installed in all horizontal runs of metallic conduit installed in-walls and exceeding 10’ in length.
  10. Surface mounted steel or aluminum raceway to be used for exposed raceway mounted on walls.
  11. Sleeves
    1. Indoor sleeves for low voltage wiring shall be EMT with bushings installed on each end.
    2. Underground sleeves to be PVC Schedule 80.

12. Conduits (including couplings, fittings, boxes, and covers) located above ceilings and exposed in mechanical and electrical rooms shall be colored their entire length. Sporadic spray painting of couplings and conduit is not permitted. Colors determined by Table below.

<b>Conduit &amp; Box Colors</b>	
<b>Electrical System</b>	<b>Conduit &amp; Box Color</b>
120/208V Normal Power	Silver (Unpainted)
120/240V Normal Power	Purple
277/480V Normal Power	Yellow
Emergency Power	Orange
Standby Power	Green
Fire Alarm	Red
Telecommunications	Blue
Security / Access Control / CCTV	White
Lighting Controls	Black

13. Exception: Conduit 1¼" and larger shall have all fittings, junction boxes, and covers colored. Conduit shall be neatly identified on 5' intervals using rust resistant tape or 2" wide colored tape to match the color of the electrical system installed.
14. Conduits located in areas with exposed ceilings may be painted to match surroundings if couplings and box covers are painted per Table and approved by University Project Manager.

C. Conductors

1. Conductors/Cabling to be copper THHN, THHW, or XHHW.
2. The use of aluminum conductors is not permitted.
3. Minimum conductor size to be #12 AWG.
4. Conductors sized #10AWG and #12 AWG to be solid.
5. Conductors sized #8 AWG and larger to be stranded.
6. Stranded conductors shall be provided for:
  1. Terminating motors or other vibrating equipment.
  2. Exterior lighting.
  3. Terminating LED lighting fixtures.
7. The use of Type MC Cable is not permitted except for:
  1. Light fixture whips.
  2. Fishing wire in existing walls (terminate MC cable in J-box above ceiling to minimize length of MC cable).
8. The use of Type NM (Romex) cable is not permitted.
9. All conductors shall be in conduit.

10. All conductors/cabling shall have colored insulation their entire length. Phase tape is not permitted. Colors determined by Table below.

<b>Conductor Insulation Color</b>		
<b>Phase</b>	<b>120/208V</b>	<b>277/480V</b>
A	Black	Brown
B	Red	Orange
C	Blue	Yellow
Neutral	White Striped *	Gray Striped *
Ground	Green	Green w/Yellow Stripe

\*The neutral wire shall be striped with the color of the phase conductor. Multi-wire circuits using a common neutral are not permitted.

**D5020 Lighting and Power Branch Wiring**

D5021 Branch Wiring Devices

A. Receptacles

1. Approved receptacle manufacturers:
  1. Hubbell
  2. Leviton
  3. Pass & Seymour (Legrand)
2. All receptacles to be rated a minimum of 20A. The use of 15A receptacles is not permitted.
3. All receptacles to be UL listed, Federal Specification grade.
4. Receptacle cover plates shall be stainless steel unless otherwise approved by University Project Manager.
5. Receptacles on emergency power shall have cover plates engraved with "EMERGENCY" in red letters.
6. Receptacles shall be colored as follows:
  1. Normal Power – Gray
  2. Normal Power Controlled by BAS – White
  3. Emergency Power – Red
  4. Isolated Ground - Orange
7. Receptacles required to be controlled per ASHRAE 90.1 shall be fed from their own intelligent panel. No other loads shall be fed from these panels. Panels shall be integrated with the Building Automation System and shall utilize BACnet over IP/MSTP communication protocol.

B. Junction Boxes and Outlet Boxes

1. Outdoor enclosures to be NEMA 3R or NEMA 4.
2. Indoor enclosures may be NEMA 1 in dry areas.
3. Indoor enclosures shall be NEMA 3R in areas exposed to moisture.
4. Minimum box depth 2.125".
5. Junction boxes shall be color coded per Conduit and Box Color chart.

- 6. Labeling
  - 1. Exposed: Provide permanent labels.
  - 2. Above Ceiling: Provide permanent labels or permanent marker.
  - 3. Lighting Controls box covers labeled with white stencil "LC".
- C. Electrical Identification
  - 1. Junction boxes shall be permanently labeled indicating panel of origin, circuit number(s), and voltage.
  - 2. Conductors shall be labeled with standard vinyl cloth, self-adhesive cable/conductor markers, wrap-around type; pre-numbered plastic coated to show circuit identification. Labels shall be installed within close proximity to terminations.
  - 3. Receptacle cover plates:
    - 1. Shall be labeled with panel of origin and circuit number.
    - 2. Labels shall be self-adhesive and have clear background with ¼" high lettering.
    - 3. Lettering color determined as follows:
      - 1. Normal Power - Black Letters
      - 2. Emergency Power - Red Letters
  - 4. Electrical Panels and Equipment:
    - 1. Shall be labeled with engraved nameplates.
    - 2. Shall be 1/8" thick by 1" high melamine plastic laminate engraved with ¼" minimum sized letters.
    - 3. Shall be installed with self-tapping screws.
    - 4. Shall be installed in visible location. Locating nameplate behind access door is not permitted.
    - 5. Shall be installed on electrical cabinets, major electrical equipment, safety switches, transformers, circuit breakers located in feeder style panelboards, etc.
    - 6. All Electrical Equipment above ceiling shall be identified on ceiling grid or access panel with a ½" wide all-weather label, clear with black writing.
    - 7. Nameplate color and letter color as follows:

<b>Electrical Panel and Equipment Identification Color Code</b>	
<b>Electrical System</b>	<b>Nameplate Color</b>
120/208v Normal Power	White w/ Black Lettering
277/480V Normal Power	White w/ Yellow Lettering
120/208V Emergency Power	White w/ Orange Lettering
277/480V Emergency Power	Orange w/ White Lettering
120/208V Standby Power	White w/ Green Lettering
277/480V Standby Power	Green w/ White Lettering
120/240V Three Phase	White w/ Purple Lettering
240V Three Phase	Purple w/ White Lettering

## D5022 Lighting Equipment

## A. Equipment

1. Approved manufacturers for general lighting fixtures:
  1. Hubbell
  2. Cooper (Signify)
  3. Philips Lighting
  4. Acuity
2. Lighting lamp type shall be LED. Fluorescent and incandescent are not permitted.
3. Interior light color shall be 3500k unless otherwise noted by University Project Manager.
4. Recessed Canister Lights shall have an opening  $\geq 4$ " to provide access to fixture mounted driver. If smaller diameter lights are used, remote mount drivers in an accessible location.
5. "EXIT" signs shall be green.

## B. Controls

1. Building Level
  1. Areas Controlled
    1. Corridors, hallways, common areas, lobbies
  2. Schedule
    1. Controlled by BAS at relay/switch panel.
  3. Approved Manufacturers
    1. nLight (Acuity)
    2. Leviton
    3. Square D (Schneider)
  4. Building level lighting controls shall utilize BACnet over IP/MSTP communication protocol.
  5. Building level lighting controls shall be connected into the building automation system through an additional set of contacts on the motion sensor and hardwired into the VAV binary input. This will allow the motion sensor on the lighting control system to also control HVAC occupancy. Lighting Contractor and Controls Contractor should coordinate for implementation.
2. Room Level
  1. Areas Controlled
    1. Offices, classrooms, labs, etc.
  2. Schedule
    1. Occupancy sensors and manual room controls
  3. Approved Manufacturers
    1. nLight (Acuity)
    2. Sensor Switch (Acuity)
    3. Wattstopper (Legrand)
    4. Hubbell
    5. Greengate (Cooper/Signify)
    6. Lutron

3. Lighting Control Contractor shall:
  1. Provide a single line diagram located at the main lighting controller identifying all components of the lighting system.
  2. Provide software needed to troubleshoot or add/remove devices to the system.
  3. Label all cables at the point of termination or connection. Labels shall identify the trunk line or control backbone and any fingers branching from the backbone. It shall also identify the device connected.
  4. Cables shall be neatly terminated at each device and all cables trimmed to length.
  5. Cables shall not be rolled up and zipped tied in excessive lengths.
  6. Low voltage terminations shall be made inside a junction box or enclosure. This includes devices and fixtures.
  7. Power pack relays or power supplies shall be installed using (2) junction boxes (side by side). One box will be provided for the power pack and line voltage, the other for the low voltage to the sensor.
  8. Provide a 20A rated single pole keyed switch ahead of the line voltage for service to the power packs.

**D5030 Communication & Security**

## D5032 Intercommunication &amp; Paging System

- A. Two-Way Communication Systems for Elevator Landings and Area of Refuge:
  1. Voice over Internet Protocol (VoIP) system.
  2. Non-proprietary, field programmable.
  3. Provide a 1" conduit homerun from the Telecom Room to the Two-Way Communication Command Unit.
  4. Locate the Command Center adjacent to the main fire alarm panel.
  5. Provide a sub-master station adjacent to a remote command fire panel or at building main entrance used for first responders.
- B. Building Elevator Phones:
  1. Equal to Viking E-1600-02A.
  2. Non-proprietary, field programmable.
  3. Flush mounted.
  4. The phone electronics should be accessible by removing the flush-mounted phone cover, not by having to remove any other elevator control panels.
  5. Provide a 1" conduit homerun from the Telecom Room to each elevator controller box in the elevator control room with a double gang box installed no more than 12" from the elevator controller box.

## D5034 Call Systems

- A. Follow the TIA/EIA 568B wiring standard as developed by the Telecommunications Industry Association (TIA) and the Electronic Industries Alliance (EIA).
- B. Quality Assurance:

1. Contractor's on-site superintendent must possess Building Industry Consulting Services International (BICSI) Installer 2, Copper Certification.
    1. Certification to be forwarded to OIT PM.
  2. Contractor shall provide successful Category 6 test results – See testing requirements.
- C. A Category-6 structured cabling design and installation is required.
- D. Telecommunication cable pathways shall not exceed 90 meters from the telecommunication room (TR) to the outlet.
- E. Provide a Building Entrance Terminal (BET) / Main Distribution Frame (MDF) where all copper, fiber, and coaxial outside plant cables enter the building.
- F. Larger buildings may require additional Intermediate Distribution Frames (IDF) in separate telecom rooms.
- G. Backboard:
1. Constructed of ¾" fire retardant AC-grade plywood painted Battleship Gray on all sides.
  2. 4'x8' plywood mounted vertically to all walls in every telecommunications room.
- H. Conduits entering the telecom room shall terminate at the backboard edge either directly above or directly below the plywood backboard to minimize the routing of cables around the room. No telecom conduit should penetrate the ceiling or floor more than 3" from the wall that supports a backboard.
- I. A ground busbar shall be installed on the backboard in each telecom room. This busbar shall be connected to the Building Entrance Service Ground Busbar (BESGB) with an insulated copper conductor sized according to length from the BESGB. The busbar shall be a minimum of a ¼"x 4"x 20" copper busbar with stand-off insulators for backboard mounting and mechanical connections for ground conductors.
1. Typical busbar layout drawings:  
<https://auburn.edu/oit/pdfs/telecom/BusbarDrawing.pdf>

- J. A wire basket-type cable tray shall be installed at the top of the telecom back board and shall circumnavigate the entire telecom room between 90" and 96" AFF. Any conduits that enter the room shall be connected to the cable tray by either direct mechanical connection or via a cable tray bridge. Telecom cabling is never allowed to hang in free space without support. This tray shall be a minimum 4"x12" Cablofil CF105 or exact equivalent wire basket tray in size and finish in the Telecommunications Room.

**Metallic Barrier 4-in from  
one side for other non-OIT  
Low Voltage cabling**

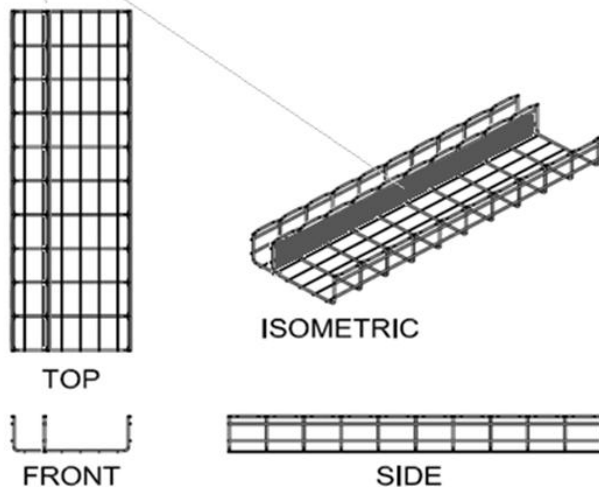

AU STANDARD SIZE WIRE BASKET CABLE TRAY 4"H x 12"W x 120"L  
Trapeze or Wall bracket mounting only. Do not center-hang tray.

- K. Horizontal pathways shall be homerun conduit, sleeves, cable trays, and/or support hooks or rings.
- L. Cable trays are recommended along all hallways, corridors, attics, or any other places where it is practical, and should be extended into each telecommunications room. Cable trays should be used whenever possible, especially for large projects. Cable tray sections should be sized to accommodate up to six Category-6 cables per telecom outlet box to be served by the section of cable tray under consideration. The support span for cable support systems should be determined in accordance with the manufacturer's maximum recommended load capacity for a given span. OIT should be consulted when it is necessary to use hooks or rings. Distance between hooks/rings should not exceed 36". When using hooks/rings, multiple 4" sleeves must be installed into each telecommunication room from the above ceiling hallway for access to the hooks/rings. The cable hooks must be rated by the manufacturer for the use of Category-6 data cabling. Ordinary cable hooks are unacceptable.

- M. Cable tray rails shall not be cut to accommodate obstructions. Cable tray supports shall be located so that connections between sections of the cable tray fall between the support and  $\frac{1}{4}$  of the span. Provide supports within 24" on each side of connection to a bend, tee, or cross.
- N. Cable tray or hooks are not to be installed over hard ceilings with a length greater than 72".
- O. Where cable runs must cross a hard ceiling with a length greater than 72", conduit transitions must be installed.

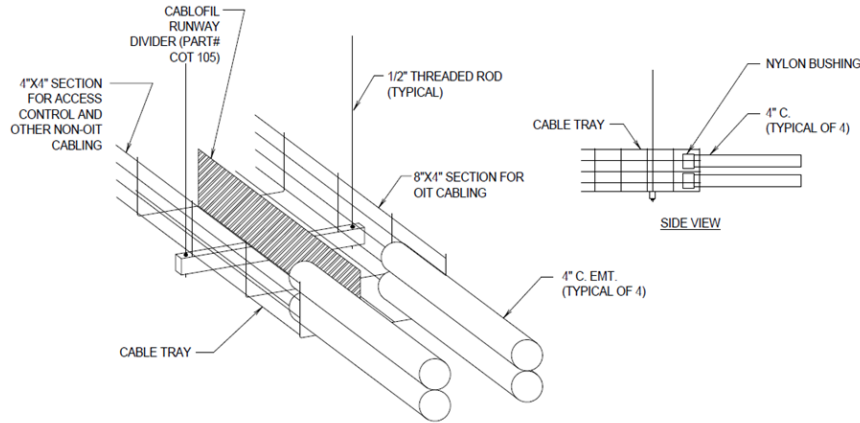

**NOTES:**

1. BRING CABLE TRAY TO THE BOTTOM OF THE CONDUIT. THE (2) BOTTOM CONDUITS OF THE 2x2 ARRAY SHALL BE IN CONTACT WITH THE BOTTOM OF THE CABLE TRAY.
2. ALL DISCONTINUOUS SECTIONS OF CABLE TRAY SHALL BE JUMPERED WITH A #6 AWG CONDUCTOR. RUN JUMPER ON OUTSIDE OF CONDUITS.

**CABLE TRAY TO CONDUIT DETAIL**

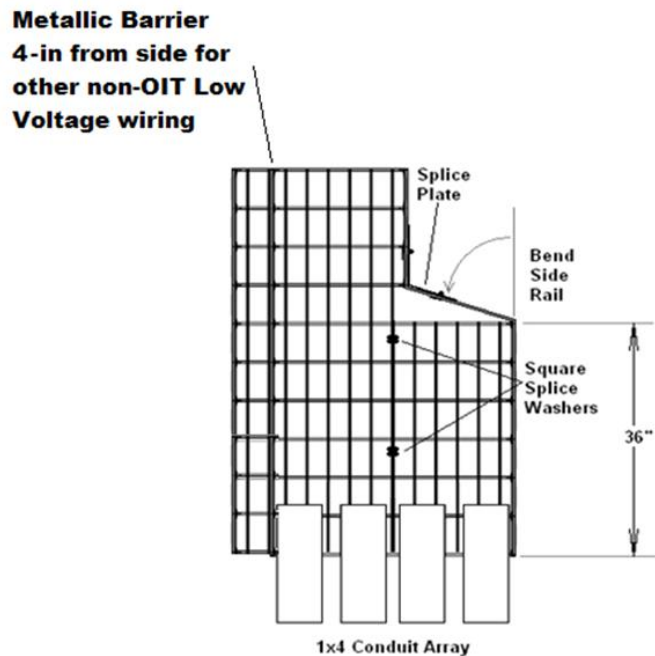

- P. The cross-sectional area of the conduit transitions must equal the cross-sectional area of the cable tray.
- Q. Cable trays and J-Hooks are to be installed not more than 24” above a ceiling grid. When designing the pathway for a cable tray, Designers of Record are to ensure that there are 6” of clearance above the cable tray and to one side of the cable tray. No other trade shall install any piping or equipment within 6” above or to one side of the cable tray.
- R. Each telecommunications outlet box requires a 1” EMT conduit to be installed from the outlet box to the nearest cable tray or hooks or to the telecom room. A pull string must be installed in each conduit. Where a cable tray is used, the conduits shall make a mechanical connection to the tray at the top rail with a nylon bushing. No gaps between conduit and cable trays are permitted. Where cable hooks are used, the conduits should terminate within 6” of a cable hook in the above ceiling corridor. Pull boxes shall be installed for every 180° of bend in a conduit and notated on drawings. Maximum continuous conduit length between pull box is 100 feet. All pull boxes shall be installed above corridors where cable trays or cable hooks are not used.
- S. In the construction of parking decks, all in-slab or in-column telecom conduits must be 1” PVC Schedule 40. Electrical Nonmetallic Tubing shall NOT be used.
- T. All cable trays shall be grounded to the telecom room busbar with an AWG #6 solid conductor as they pass by the TRs and all discontinuous sections of cable tray shall be connected with an AWG #6 solid conductor jumper wire. All conduits that are not mechanically bonded to the cable tray shall be bonded using a #6 bonding jumper from conduit to cable tray.
- U. Backbone Pathways consists of both intra-building and inter-building facilities.
- V. Intra-building backbone pathways are necessary for the installation of telecommunication riser cables between various telecommunication rooms (BET, MDF and IDF locations) within a building. Each IDF telecom room should be connected to the BET/MDF telecom room via dedicated conduit. In multi-story buildings, it is best to stack the telecommunication rooms when possible and connect the rooms with multiple 4” sleeves between floors. A dedicated 4” sleeve or conduit should be installed from the BET/MDF telecom room to each IDF. When IDFs cannot be stacked, then consult OIT for proper sizing of conduits between the BET/MDF and IDFs. A pull box is required for every 180° of total bend in the conduit.
- W. Inter-building backbone pathways are facilities necessary for installation of telecommunication outside plant trunk/feeder cables between buildings. Telecommunications service entrance pathways shall be specified to support the initial and anticipated wireline and wireless telecommunications needs of the total building area served. In determining the total number of pathways required, the planner shall consider.
  - 1. Type and use of building.
  - 2. Growth.
  - 3. Difficulty of adding pathways in the future.
  - 4. Alternate entrance.
  - 5. Type and size of cables likely to be installed.

- X. Additional pathways may be specified by OIT for off-campus projects where the building may be served by both the university as well as commercial telecommunications service providers. Consult OIT for specific design needs.
- Y. Outlets:
  1. Telecommunication outlet boxes shall be installed wherever telephone, computer, and/or cable television, or any audiovisual service is required. Generally, voice and data jacks in offices, classrooms, conference rooms, etc., will share the same outlet box. It is not necessary to install a separate outlet box for voice and data with the exception of wall mounted telephone locations. For known cable television outlet locations, a separate outlet box may be desired and should be installed at the location requested. Telecommunication outlet locations should be coordinated with the furniture layout.
  2. A standard double-gang electrical outlet box (4"x4"x2" deep) should be installed at each telecommunication outlet. All outlet boxes are to be securely fastened to the studs of the interior wall. A 1" conduit should be installed from the outlet box, running up the interior of the wall, out into the hallway above the ceiling, and mechanically attached to the telecom cable tray. OIT recommends use of ERICO Caddy 16P24SM flange mount conduit clip. The conduit should interface the top of the double-gang outlet box at an off-center position to allow for maximum bending radius of future cable installs. A pull-string or pull-wire shall be installed in each conduit. The conduit should have no more than 180° of bends between the outlet box and the above ceiling corridor space, and therefore a junction box above the ceiling over an office should not be necessary. Do not place junction boxes above the ceilings over offices.

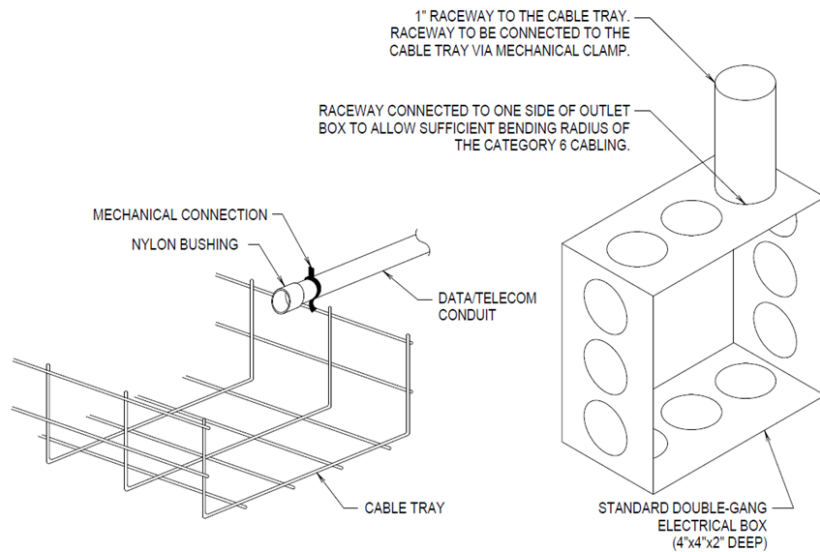

TELECOMMUNICATIONS OUTLET BOX DETAIL  
NOT TO SCALE

- The 1” conduit from each wall outlet box shall be installed to the nearest cable tray, hooks, or telecommunications room. Typical conduit to cable tray termination.

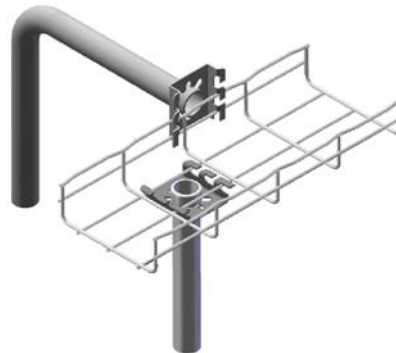

- Where it is necessary to aggregate several of these conduits into a junction box, the conduit from the junction box to the cable tray/hooks or telecommunication room shall be sized according to the number of 1” conduits being aggregated in accordance with the following conduit fill capacity chart:

trade size	inside diam. inch	inside diam. mm	cable outside diameter mm (in)									
			3.3 (0.13)	4.6 (0.18)	5.6 (0.22)	6.1 (0.24)	7.4 (0.29)	7.9 (0.31)	9.4 (0.34)	13.5 (0.53)	15.8 (0.62)	17.8 (0.70)
1/2	.622	16	1	1	0	0	0	0	0	0	0	0
3/4	.824	21	6	5	4	3	2	2	1	0	0	0
1	1.049	27	8	8	7	6	3	3	2	1	0	0
1-1/4	1.380	35	16	14	12	10	6	4	3	1	1	1
1-1/2	1.610	41	20	18	16	15	7	6	4	2	1	1
2	2.067	53	30	26	22	20	14	12	7	4	3	2
2-1/2	2.469	63	45	40	36	30	17	14	12	6	3	3
3	3.068	78	70	60	50	40	20	20	17	7	6	6
3-1/2	3.548	91	MAX	MAX	MAX	MAX	MAX	MAX	22	12	7	6
4	4.026	103	MAX	MAX	MAX	MAX	MAX	MAX	30	14	12	7
typical 2-pair CAT3 cable												
typical 4-pair CAT3 cable												
typical 4-pair CAT5E cable												
typical 4-pair CAT6 (without divider) cable												
typical 4-pair CAT6 (with divider) or 4-pair Sctp cable												
typical 12-pair CAT3 unshielded cable												
typical 25-pair CAT3 unshielded cable												
typical 50-pair CAT3 unshielded cable												
typical 50-pair CAT3 shielded ARMM cable												
typical 100-pair CAT3 unshielded cable												

- Exposed cabling should not be installed in open ceiling spaces, unless protected by a cable tray.

6. Where surface mounted raceway is installed in a room or lab, the raceway must have a metallic separation barrier between the telecom cabling and 120-VAC cabling. The cover for the raceway should be a snap-on design with pre-punched holes for telecom jacks every 36". Telecom outlet locations will be determined by OIT and the building tenants. At locations along the raceway where a power outlet is installed but no telecommunication outlet, the telecom cable channel faceplate shall be covered with a blank faceplate by the electrical Contractor. Where surface mounted raceways are required within a room or lab, the raceway must be connected via a 1" conduit for every six feet of raceway, or the equivalent thereof. Each conduit must run from the raceway to the nearest cable tray or telecom room.
7. Where floor mounted telecommunication outlets are required, specify FSR FL-500P-BLP-6 floor boxes for standard applications. FSR FL-600 should be used under lecterns in auditoriums. Covers will vary with application. Wiremold RFB4-C1-1 compartment combination floor box may also be used for standard applications. The stamped steel version shall not be used in contact with grade. Only the cast steel version is rated for grade contact applications. Coordinate with OIT when specifying floor mounted outlet boxes.
8. When the design of an office space requires the use of cubicles or other modular type office furniture, it is recommended that the furniture chosen have as part of its design an integrated raceway for installation of telecommunication cables and outlets. If the floor plan of the office space dictates the furniture to be located in the center of the room and not adjacent to any walls, the telecommunications and power access requirements may be met through closely coordinated core drills in the floor that align with the walls of the modular furniture. This is the recommended solution for modular furniture located above the ground floor of a building. For 3" thick cubicle walls, 2½" core drilled holes are recommended, with a 1½" EMT conduit installed from each core drilled hole to the telecom cable tray on the floor below. The conduit should stub into the telecom raceway within the wall of the modular furniture where it will be accessible for the pulling of the telecom wire. Where multiple contiguous modular offices are planned, a core drill should be made for every three offices. For example, two core drills strategically placed are needed for a configuration of six modular offices. Likewise, four core drills are needed for twelve offices. This method is preferred over the use of tele-power poles. OIT should be consulted for modular furniture that is to be located on the ground floor. Furniture layout should be planned such that telecommunication wiring will not be exposed. At no time is exposed telecommunications wiring from conduits to furniture allowed. Floor boxes have proven to be unworkable for modular furniture and therefore are not recommended.
9. In Lecture Halls, Meeting Rooms and similar locations where power and data are to be supplied to tabletops, the WIREMOLD DeQuorum flip-up module with a 20A duplex power outlet and dual-data outlet shall be used where such

power and data needs are required by the intended users of the room or lecture hall. Wired data outlets in portable tables are discouraged.

- Z. Provide interconnectivity between the following systems as required:
  - 1. Voice Communication Systems
  - 2. Data Communication Systems
  - 3. Building Automation Systems
  - 4. Lighting Control Systems
  - 5. Fire Alarm Systems
  - 6. Security Systems
  - 7. Access Control Systems
  - 8. Point of Sale Systems
  - 9. Closed Circuit Camera Systems
- AA. Structured Cabling:
  - 1. Audio-Video (AV) Cabling:
    - 1. For some classroom environments, Category 6A shielded cables may be required to be installed from the AV equipment rack to various AV components within the classroom, such as projectors, document cameras, podium equipment, etc. The Contractor shall NOT terminate these cables on either end (no RJ45 plug or outlet is required). After the cables are installed by the Contractor, OIT will then terminate the cables directly to the AV equipment. Consult with OIT where Category 6A shielded cabling is required.
  - 2. Coaxial Cable TV Outlet:
    - 1. CATV requires installation of a coaxial station cable from the telecom backboard to the cable TV outlet location, with the cable terminated with 75-ohm F-connector at the outlet.
    - 2. Sometimes it is required to install a cable TV port in addition to one or more Voice/Data ports or in addition to other cable TV ports in a single faceplate. For each additional port, installation of an additional coaxial station cable terminated on both ends is required.
  - 3. Voice or Data Outlet:
    - 1. Install one 4-pair Cat-6 station cable, RJ45 Jack, and faceplate per outlet.
    - 2. For each additional outlet provide a 4-pair Cat-6 station cable, and RJ45 Jack installed in faceplate for up to 6 total ports. Port total will be reduced if cable TV jacks are installed in same box/faceplate.
    - 3. Jacks shall be installed in the following configurations (labeled IAW paragraph CC. Installation Requirements, below):

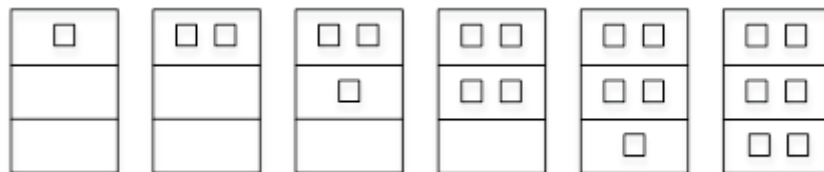

## BB. Preferred Materials Listing

1. Material List: <https://auburn.edu/oit/pdfs/telecom/MaterialsListing.pdf>
2. All materials to be pre-approved by OIT.

## CC. Installation Requirements:

1. Riser Schedule: Contractor shall pull copper riser cables between the BET/MDF and each IDF and terminate and ground each cable, 25 pair cable to the patch panel.
2. The Contractor shall pull single mode and multi-mode fiber cable homerun between the BET/MDF and each IDF leaving 20 feet of slack on each backboard.
3. Contractor shall install faceplate with blank inserts on all unused telecom wall boxes.
4. Contractor shall get approval from OIT on location of equipment in the telecommunication rooms to include racks and patch panels.
5. Terminate horizontal station cables at patch panels. Terminations shall be initially organized sequentially in ascending order according to their label identification - i.e., with the lowest room/space number in the top left corner of the top patch panel, continuing left-to-right and top-to-bottom. (It is understood that later cable adds/modifications may not connect in this initial sequential order but will be added at the bottom of the patch panels.) All Wireless Access Point patch panel terminations shall be grouped together and all Classroom Tech (A/V) patch panel terminations shall be grouped together. Provide D-Rings to route station cables in orderly manner from entrance to the backboard to the panel.
6. Use Velcro ties for bundling of cables. Zip ties are not allowed.
7. All backboard terminations shall be labeled with official room number, jack number and port number.
8. CATV port – leave 8-10” of cable slack in the back box behind the faceplate.
9. Labeling Requirements:
  1. Each jack faceplate shall have two built-in label slots with clear plastic removable covers. Each jack will be labeled according to the room number and jack number. In rooms where more than one jack is located, sequential jack numbering is required. For example, Jack 123-1 is located in Room 123 and is the first jack in the sequence. Jack 123-4 is also located in room 123 and is fourth in the sequence of jacks. A computer printed label is required with bold lettering to be installed in the label slots of the faceplate. Hand-printed labels are not acceptable.
  2. Each port shall be labeled on the backboard terminations. For example, if the backboard termination hardware (patch panel) label states 123-1-1, it indicates this jack and port are located in room 123, faceplate 1, port 1. A backboard termination label that states 123-4-2 indicates the jack is located in room 123, faceplate 4, port 2. Accurate labeling of jacks and backboard terminations is essential to testing, installation, and troubleshooting.

3. Backboard terminations connected to Wireless Access Points (WAP) must be labelled similarly to faceplate and port terminal requirements. For example, if the backboard termination hardware (patch panel) label states WA123-1, it indicates this WAP is in room 123. A backboard termination label that states WA123-2 indicates the second of multiple WAP's in room 123. WA123 indicates a WAP in a hallway or public space outside room 123.
4. AV jacks shall be labeled AVf#xxxxs#, where: 'AV' indicates it is an audio/visual connection, 'f#' indicates the room number (or floor number, if specific room is not identified) of the building, 'xxxx' indicates the category of AV connection ('data' for data, 'spk' for speaker, 'aud' for audio, 'vid' for video. And 'CTL' for control), and 's#' indicates the sequential numbering of connections on that floor. Example: AV2spk3 would be the third speaker connection on the second floor, or AV351vid2 would be the second video connection in room 351.
5. Data jacks NOT in a wall shall have a designation before the room number indicating they are in either the floor or overhead. For example, "AV" for audio/visual connections, "WA" for wireless access points, "FB" for floor boxes.
6. Labels shall be produced using the Arial Bold, size 8, font.

DD. Testing Requirements:

1. DC Electrical Tests to be performed - All jacks are required to be tested after installation and before being put into service by the installation Contractor using industry-accepted methods. The jacks, the four-pair data and voice cables, and the backboard termination hardware are to be tested for continuity of the tip and ring of each pair, polarity of the pair, crossed conductors between pairs, shorted pairs, and grounded pairs.
2. AC Electrical Tests to be performed - Each cable pair is to be tested end-to-end with a certified Category-6 cable tester. The Contractor will verify that each cable has passed Category-6 testing with a certified tester and that all of the parameters programmed into the tester before the test are correct. Such parameters include the proper velocity propagation factor, impedance, and capacitance listed by the cable's manufacturer. All cable testing results are subject to review and to re-test verification by OIT personnel to ensure the proper testing methodology is used. The Contractor is required to ensure that every cable meets the Category-6 standard. Any cable that does not meet this standard will be rejected. The Contractor will then be required to take the appropriate remedial measures to bring the jack, cable, and hardware circuit under test into compliance with Category-6 standards at the Contractor's expense. Testing with a Category-6 tester can accomplish the AC and DC tests provided that in addition to cable propagation and data speed testing, the continuity of the tip and ring of each pair, polarity of the pair, crossed conductors between pairs, shorted pairs, and grounded pairs are also tested with the Category-6 tester. Testing will be conducted from the voice and data jack to the corresponding terminations on the backboard termination hardware at the BET or IDF, wherever the appropriate final termination of

the cable occurs, to make the station cable PERMANENT LINK COMPLIANT with ANSI TIA/EIA568B.2-1

3. Category-6 Results Submissions - The installation Contractor shall test every cable installed and shall test for all the parameters for Category-6 standards. Upon completion of cable terminations, the Contractor shall within 5 business days provide OIT with an electronic copy of the testing data of every cable contained within the job. OIT will conduct a field test audit of the total cabling to ensure that the Contractor's test data correlates with the data obtained from the field audit. The tests conducted by OIT are the final determinant of whether the cable passes or fails Category-6 standards. The Contractor will be required to re-test every cable in a job if the audit shows that the data of the audit substantially differs from the submitted results. Any cable not passing the audit will be required to be repaired or replaced.
4. Testing Instructions – Fiber
  1. All testing will be performed in strict accordance with the following guidelines and procedures. Any deviation from these guidelines and procedures must have prior approval from the appropriate Auburn University (Owner) representative. The Owner will reserve the right to change or alter these procedures at any time for any reason.
  2. Any test results that fail to fall within the limits of the below-referenced standards shall be deemed unacceptable by the University.
  3. Any unacceptable results will require the re-termination and re-test of the affected fiber. If subsequent attempts to re-terminate and/or re-splice are unsuccessful at obtaining desired results, it is the sole responsibility of the Contractor to replace any and/or all cables, splices, and terminations at no additional cost to Owner.
  4. References:
    1. ANSI/TIA/EIA-526-7, Method: Optical Power Loss Measurements of Installed Single-Mode Fiber Cable Plant, ASI/EIA/TIA-568-A.
    2. Annex H: Optical Fiber Link Performance Testing.
  5. Guidelines:
    1. Connect a jumper to the optical source and the optical power meter.
    2. Turn the units on.
    3. Record the reference power reading (Pref) displayed in dB.
    4. Using an adapter, insert a second jumper between the jumper used in step 1 and the optical power meter.
    5. Record this power level in dBm as Pcheck.
    6. Use the following equation to ensure the attenuation added by the second jumper is not greater than 0.75dB:  $Pref - Pcheck < 0.75Db$ .
      1. Satisfied, continue to step 8.
      2. Not satisfied, clean all connectors except the optical source connection point and repeat the procedure starting with Step 4. If the result is still greater than 0.75dB, replace test jumper 2 and repeat the procedure again, starting with Step 4.
    7. Leave the jumpers attached to the optical source and optical power meter. Do not reset the power meter.

8. Disconnect the two jumpers at the adapter. Do not turn off the power meter or source.
9. Attach the optical source/test jumper 1 to one end of the segment to be tested.
10. Attach the optical source/test jumper 2 to the other end of the segment.
11. Record the test power P<sub>test</sub>.
12. Subtract the test power (P<sub>test</sub>) from the reference power (P<sub>ref</sub>) recorded in Step 3 to determine the end-to-end attenuation:  

$$\text{Attenuation (dB)} = P_{\text{ref}} - P_{\text{test}}$$
5. Attenuation Acceptance Values – Fiber OSP
  1. Tested in one direction and at both wavelengths. Link attenuation is calculated as:
    1. Link attenuation = Cable attenuation + connector attenuation + splice attenuation.
    2. Cable attenuation (dB) = attenuation coefficient (dB/km) length (km).
  2. The cable attenuation coefficient is determined as follows:

Cable Type	Wavelength	Attenuation/Coefficient (dB/km)
Single Mode Outside Plant	1310	0.5
Single Mode Outside Plant	1550	0.5
Single Mode Inside Plant	1310	1.0
Single Mode Inside Plant	1550	1.0

3. Connector attenuation (dB) = Number of connector pairs (N) x splice loss (dB) = S x 0.3 dB = N x 0.5 dB.
4. Splice attenuation (dB) = Number of Splices (S) x splice loss (dB) = S x 0.2 dB
5. Upon completion of the above test, the Contractor will be required to submit one (1) copy of a written and one (1) electronic report detailing the test results for the Owner's review, prior to the final acceptance testing. The electronic report must be in a format agreed upon by the Owner before testing begins.
6. OSP Testing and Acceptance – Copper
  1. The Contractor will provide a thorough testing program for the copper cabling. Final acceptance testing shall be performed jointly by the Contractor and the owner. The Contractor will provide proposed testing procedures and test equipment to the owner prior to the commencement of the tests. The testing will include continuity, transmission loss test (dB loss), splice loss test (dB losses), and other cable system testing normally performed. All faults will be corrected and re-tested. The test will be performed with the manufacturer’s recommendations.

2. Copper testing will consist of testing for:
  1. Conductor continuity.
  2. Shield to ground (Meg. Test). Cables must meg to infinity.
3. Cable testing will be performed on a per pair basis. Cable Meg testing will be performed on a per section basis.
4. Acceptance Testing will be performed by the Contractor and observed by the Owner. These tests will include testing on 10% of the cable pairs for each cable installed to verify conformance to the specifications.
5. Complete re-testing will be performed, and any necessary corrections made, should any acceptance test fail to meet specified standards.
6. The Contractor will furnish one (1) complete set of all test reports and records. This set will consist of an electronic copy or a hard copy or both of all test reports and drawings showing as-built and installed cable routing, termination points, copper assignments, and termination block wiring. This must include all copper pre-installation tests, splice test, and final installed test results.
7. Owner acceptance of the system will be accomplished on the satisfactory completion of the acceptance test and receipt of all final test reports by the Owner.

#### D5037 Fire Alarm Systems

##### A. Equipment

1. Fire alarm system shall be networkable, addressable type, voice capable type and incorporate Mass Notification/Emergency Communication and shall be fully compatible with existing Johnson Controls Fire Protection campus network.
2. Visual notification devices shall incorporate dual strobes Amber marked "Alert", and clear marked "Fire".
3. Weather resistant outdoor speakers installed in a sealed weather tight Back Box should be installed at entrances and other gathering points near building.
4. Visual text displays shall be placed in elevator lobbies, large assembly areas, and main paths of egress.

##### B. Fire Alarm Control Panel (FACP) Network Connection

1. Auburn University uses Simplex Fire Alarm Systems. The Designer of Record shall specifically spell out in the specifications and note on the drawings that the FACP is to be connected to the nearest Telecom Room with a homerun 1" conduit. This is a requirement of Auburn University. A pull box is required for every 180° of total bend. Provide pull string in conduit.

##### C. General

1. Main fire alarm control panel shall be in the electrical room.
2. Fire alarm control panel and RCC (Remote Command Center) shall include buttons for activating pre-programmed messages locally at building.
3. Fire alarm system conduit, fittings, junction boxes, and covers shall be painted red.

4. On multi-story buildings, fire alarm riser shall have fire alarm terminal cabinet on each floor.
5. A pull station is required at the exit of every mechanical and/or electrical room.
6. All buildings shall have speaker layout designed to ensure intelligibility and audibility.
7. All Fire Alarm/Mass Notification systems must be integrated with the command center at the Auburn University Campus Safety Building.
8. All Fire Alarm/Mass Notification systems must have the ability to activate no fewer than 12 pre-programmed and manual evacuation messages as well as live public address (campus wide or building only).
9. No copper wire shall be used underground to interface a fire alarm control panel in one building to peripherals or remote panels/transponders in an outlying building. In these instances, connection of fire alarm equipment in the outlying building will be connected to the main control panel via multi-mode fiber.
10. All underground conductors to post indicator valves or sprinkler valve vaults shall be installed in PVC conduits and all outdoor sprinkler equipment shall be grounded using the manufacturer provided ground terminals. Install equipment grounding conductor in conduits to connect to PIV and interior metal conduits to properly bond the connection.
11. Provide single mode fiber optic interface between building and existing campus network, utilizing 6 strand single-mode with fiber pigtail and LC angled polished connectors on network end, ST or SC connector on fire panel end (contact university fire alarm contractor to verify ST or SC per job specific requirements).
12. A 120V AC electrical outlet shall be installed in close proximity to the main fire alarm control panel for use of computers or test equipment.
13. As-built drawings will be turned in to the University Project Manager immediately upon completion of the final inspection.
14. No surge suppressors will be installed above ceilings or in areas difficult to access by maintenance personnel.
15. All fire alarm panels and terminal cabinets shall have a disconnect switch located inside the cabinet to disconnect power source for servicing. Provide a red label with white lettering to indicate electrical panel and circuit serving the fire alarm equipment.
16. All fire curtains and shutters connected to automatically close upon fire alarm signal shall automatically open (i.e., reset) once the fire alarm panel has been reset.
17. Provide a local manual open/close switch for service of each fire curtain, shutter, or door.
18. All fire alarm panels and cabinets shall be keyed with an AU BEST key core system – 704 fire alarm key.

19. Fire Alarm Building NFPA Operations Matrix.
  1. [Office](#)
  2. [Classroom](#)
  3. [Lab Classroom](#)
  4. [Dorm](#)
  5. [Food Venue](#)
  6. [Large Assembly Smoke Evacuation](#)
20. Fire alarm wiring requirements.
  1. [Fire Alarm Wiring Requirements](#)

#### D5038 Security & Detection Systems

##### A. Electronic Access Control System (EACS)

1. The Standard does not provide a solution for every type of opening that may occur on the Project. The Designer of Record shall become familiar with and interpret this section of the Design and Construction Standards in accordance with the programmatic requirements of the Project. Access Control and Security requirements for each project shall be evaluated and determined by the Project Delivery Team during the Schematic Design Phase. If variations are recommended, these shall be reviewed and approved by the University Project Manager, prior to inclusion into the Bid Documents.
2. Access Control System and Card Access System shall be Lenel OnGuard. This is a Sole-Source system. Substitutions are not acceptable. EACS shall be able to fully communicate and provide full function with existing Lenel OnGuard system.
3. Although a Security Consultant may be retained, the scope of work shall be provided by the Designer of Record. The EACS Contractor shall include all required License Upgrade costs as a part of the project bid package. There shall be, on average, one (1) License Upgrade per ISP (Building Controller to support 64 readers). The License Upgrade shall be given to Auburn University Access Control Center and Facilities Management Information Technology Group at the onset of the project.
4. Buildings shall be equipped with card access. All readers shall be wall or mullion mounted.
5. For buildings with an exterior access card reader, all exterior doors without card readers shall be monitored.
6. All doors, without card readers, into a space that is accessed with a card reader shall be monitored.
7. Exterior doors shall be provided with Electrified Panic Hardware and shall be monitored by the Access Control System. An exterior opening which is not hinged, such as a large sliding, overhead coiling or similar opening shall be monitored. All doors shall be prepped for future EACS upgrade. Prep should include the following:
  1. Frame should have EPT prep with raceway to junction box above the ceiling at the door.

2. Frame should have prep for Door Position Switch (DPS) with raceway to junction box above ceiling at the door.
3. Door should have EPT prep with cross bore to lock pocket.
4. Wall on the latch side of frame and door should have 4" square box with single gang tile/mud ring and stainless-steel blank plate. Also provide raceway from this JB to JB above ceiling at the door.
8. All cable shall be in minimum 3/4" conduit from door to cable tray and from cable tray to head-end panels. Home run conduit from junction box to security panel shall be minimum 1" conduit. All conduit and cable shall be concealed.
9. All cable shall be shielded, and plenum rated.
10. General: Card readers shall be provided in the following locations:
  1. Main [ADA-compliant] entrance along the accessible route.
  2. Secondary entrances.
  3. Classrooms in excess of 100 seats.
    1. Primary entry door must have reader.
    2. Secondary door or doors may have reader but must be electrified and prepped for future reader. Same conditions as listed above.
    3. Tertiary doors that will be for egress only with no plan to electrify or reader them in the future, must be monitored.
  4. Multimedia/Control Rooms
  5. Computer Laboratories
  6. Instructional and Research Laboratories
  7. IT/Telecommunication Closets
  8. Mechanical/Electrical Rooms
  9. Exterior openings to a single room with an interior door.
  10. Other such vital infrastructure spaces.
  11. Additional openings may be provided with card readers, if desired by the Project Delivery Team.
11. Door Wiring Drawings
  1. Door Hardware Standards
    1. [Door Hardware Standards](#)

#### D5039 Local Area Networks

- A. Utilize the following symbol to represent WAP on documents:



- B. When a network wireless access point (WAP) is required to be on a hard ceiling or on some architectural ceiling design feature, the Designer of Record will ensure

that the design incorporates and supports wireless access point installation on the ceiling or design feature, whichever is lowest, with a telecom conduit to a double-gang box with easy access to the units for maintenance. AU Telecom WAPs do not need a power outlet as our design supplies power-over-ethernet (POE) to the WAP.

- C. WAP installation requires Contractor to install one Category-6 network station cable and the WAP equipment. The station cable is to be terminated on one end at the nearest network IDF backboard and on a biscuit jack above the ceiling at the specified location (in lift-out ceiling locations). The station cable must have an additional 15 feet of slack for future re-positioning of WAP location if necessary. The WAP equipment is to be mounted below the ceiling on the ceiling grid and connected to the above ceiling biscuit jack via a 3-foot patch cord. The station cable must be marked on both ends (IDF and biscuit jack) with WAP location as supplied by OIT. The WAP and ceiling grid mount hardware will be supplied by OIT.
- D. It is required that the Contractor place each WAP at the exact location indicated on the provided drawings. The exact location is defined as an 18" radius of the directed location as indicated on the drawings. If installation at the location indicated is impossible due to obstructions in or above the ceiling, the Contractor shall immediately contact OIT to discuss relocation of the WAP. At no time should the Contractor make the determination to install the WAP outside the directed location without consultation with OIT. If the Contractor is unable to contact an OIT representative immediately then installation of that particular WAP shall be delayed until such time as the consultation can take place. Installed WAP locations will be checked by OIT. If the Contractor is found to have failed to adhere to the above instructions, the Contractor shall relocate any and all WAPs deemed by OIT to have been improperly located at no additional charge to Auburn University.
- E. Drop Ceiling Installation: Wireless Access Points (WAP) shall be attached to the drop ceiling grid. When the ceiling grid is hidden, or otherwise unreachable, other mounting accommodations must be approved by OIT. If you are not sure of the placement or proper mounting, contact the OIT Project Manager.
- F. Open Ceiling Installation: Wireless Access Points (WAP) shall be installed using a 1" conduit from the nearest cable tray, hooks, or telecommunications room turned down at a 90° angle to a single gang electrical box. The single gang box and the WAP should be installed facing the floor. The WAP should be at or below the lowest height in comparison to Fire Alarm strobes, area lighting units, or motion detectors.
- G. Inaccessible Ceiling Installation: Wireless Access Points (WAP) shall be installed in a manner as similar to Open Ceiling Installation as possible. The design of acceptable options must be pre-approved by OIT. Wireless Access Points (WAP) installed in inaccessible ceilings (such as locking grids, sheetrock, or watertight areas) shall utilize a 1" conduit to a single gang electrical box from the nearest cable tray, hooks, or telecommunications room. The design of acceptable options must be pre-approved by OIT. Wall locations are not ideal but when used the

WAP should be mounted to a vendor specific, OIT approved, bracket using a 1” conduit from the nearest cable tray, j-hooks, or telecommunications room.

- H. All removable ceiling installations require a 15’ CAT6 cable service coil to be included.
- I. Outdoor WAP Installation: Outdoor WAP installations will require separate power source and a lockable weather-proof NEMA enclosure. Coordinate with University Project Manager on paint color(s) for NEMA enclosures. Color to match adjacent substrates.

## **D5090 Other Electrical Services**

### **D5091 Grounding Systems**

- A. Ground rods shall be 10’-0” copper clad steel rods. Top of rod to be driven to a minimum of 2’ below grade.
- B. Underground grounding connections shall have exothermically welded connections. Mechanical connections are not permitted underground.
- C. Provide inspection well for buried grounding connections. Locate inspection wells as close to main electrical service equipment as possible.
- D. Ground rods shall not be installed under sidewalks, parking areas, or other areas where they cannot be inspected.
- E. GPS locate and document location of all ground rods, conductors, and inspection wells.

### **D5092 Emergency Lighting and Power**

- A. Approved manufacturers for emergency generators:
  - 1. Caterpillar
  - 2. Cummins/Onan
  - 3. Kohler
  - 4. MTU On-Site Energy
  - 5. Generac
- B. Provide generator docking station. Docking station to have the following:
  - 1. Manual failsafe operation to separate permanent generator from portable generator.
  - 2. Female camlock connections for load bank testing.
  - 3. Male camlock connections for portable generator hookup.
  - 4. Auxiliary contacts for control wiring. Control wiring to be provided between docking station and ATS.
  - 5. Locate docking station in an accessible area so portable generator can be connected within 50 feet of the building.
- C. Approved fuel types:
  - 1. Diesel fuel
  - 2. Natural gas
- D. When using diesel fuel:
  - 1. Provide belly tank sufficient to supply any fire pump start/operation for 2.0 hours plus all other rated/connected loads for 48 hours.

2. Provide fuel consumption calculations.
3. Underground fuel tanks are not permitted.
- E. Automatic transfer switches shall be equipped with isolation maintenance bypass.
- F. Remote generator annunciator shall be provided.
- G. Provide generator connections to BAS to provide status monitoring and alarms for generator functions.
- H. Provide ATS contacts to BAS for monitoring switch position.

D5094 Other Special Systems and Devices

- A. Lightning Protection
  1. Lightning protection systems shall be passive.
  2. Specifications shall be included that comply with NFPA 780, UL96, and UL96A.
  3. Lightning protection system shall be installed by a qualified UL or LPI installer.
  4. Upon completion, a UL Master Label or LPI System certificate shall be provided to Auburn University.

**Document Revision History**

Version	Section	Summary of Change	Date



## 2025 Section E – Equipment and Furnishings

### INDEX

E10	Equipment
E20	Furnishings
Document Revision History	

## **E Equipment and Furnishings**

### **E10 Equipment**

#### **E1010 Commercial Equipment**

##### **E1017 Vending Equipment**

- A. University Project Manager will coordinate vending area requirements to be included in the design.
- B. Connection requirements of equipment (power, water, etc.) shall be provided to the Designer of Record and included in the design.
- C. Equipment shall be provided by the University or vending companies having contracts with the University.
- D. Drink and snack machines each require a 20A duplex receptacle.
- E. All water and electrical outlets around vending equipment shall be 18" above finished floor level.
- F. Floor finishes around vending equipment shall be hard surface (ceramic tile, etc.).
- G. If vending machines contain condensate drains, a floor drain should be provided.
- H. Place vending machines in a convenient location to serve the building occupants such as an alcove, break room, vending room, or other area as deemed appropriate by the building's user requirements.

#### **E1020 Institutional Equipment**

##### **E1027 Laboratory Equipment**

- A. Fume hoods and casework shall be selected based on:
  - 1. The needs and use of laboratory personnel and the department(s) associated with the laboratory.
  - 2. The chemicals and processes to be used which may dictate specific type of hood such as: perchloric acid, acid digestion, etc.
- B. Fume hood low airflow safety alarm consoles shall be factory and field-tested and furnished with each fume hood. Airflow measuring devices shall be capable of indicating design flow rates within +/- 20% of design flow rates.
- C. Reuse of fume hoods from existing laboratory locations shall be evaluated and approved by Auburn University Risk Management and Safety.
- D. Fume hoods shall be equipped with zone presence sensors and automatic sash closers.
- E. Fume Hood Layout and Installation
  - 1. Fume hoods shall be located away from doorways and other traffic areas or where airflow may be negatively impacted.
  - 2. Fume hoods should be labeled with engraved plastic tag to indicate which fan or ventilation system they are connected to.
  - 3. Fume hood controls and plumbing shall be located on the exterior of the fume hood.

4. Fume hoods shall be ASHRAE 110 tested after installation. Prior to ASHRAE 110 test, the HVAC system, fume hoods, snorkels, etc., shall be tested and balanced. The ASHRAE 110 must not come before test and balance of systems.
  5. If a high performance (less than 100 fpm, sash open 18") fume hood is to be considered for use in laboratories, it shall be approved through the University Project Manager.
  6. Future laboratory needs should be taken into consideration when making a fume hood selection.
- F. Provide a system test and balance report of proper function of the HVAC system and fume hood(s). This report shall be reviewed and approved by University Project Manager prior to substantial completion of the project.
- G. Local exhaust ventilation (snorkels, grossing stations, etc.) shall be compliant with ACGIH standards.
- H. Biological Safety Cabinets (BSCs) shall be certified following installation. Existing BSCs shall be decontaminated prior to moving. Certification shall be coordinated through University Project Manager.
- I. Flammable Material Refrigerators/Freezers shall be provided if flammable chemicals need to be refrigerated.
- J. Countertops shall be chemical and heat/flame resistant.
- K. Each laboratory shall have an emergency eyewash. Emergency eyewash shall be compliant with ANSI Z358.1.
- L. Each laboratory shall have an emergency shower near the main entrance. Emergency shower shall be compliant with ANSI Z358.1, including the requirement for tepid water. All emergency shower units shall be equipped with a floor drain.

#### E1028 Medical Equipment

- A. AED
1. Project budget to fund supply of AEDs as required. Designer of Record to include AED locations on Life Safety plans. Owner furnished/owner installed. (OF/OI)
  2. DOR to indicate location.
  3. Owner supplied/installed.

#### E20 Furnishings

- A. All furnishings shall be grade A and meet BIFMA (Business and Institutional Furniture Manufacturers Association) and ANSI (American National Standards Institute) standards as determined by the University Project Manager.
- B. All furnishings shall have a minimum warranty of 10 years for single shift use.
- C. Provide installation drawings during the Design Phase, color coded to indicate furniture dealer.
- D. If furnishings are selected by consultant design firm, AU Interior Designer of Record will review prior to approval for purchase.

**E2010 Fixed Furnishings**

## E2012 Fixed Casework

## A. Casegoods

1. Horizontal surfaces shall be high pressure laminate (HPL). Surfaces shall be medium density fiber board (MDF), particle board, or wheat board and must have a minimum density of 45 lb. per cubic foot. All horizontal surfaces shall be constructed to be dimensionally stable and shall be a minimum 1-1/16" thick.
  1. In Residence Halls – MDF construction is not acceptable. All components shall be minimum plywood board construction.
2. Vertical exposed veneer surfaces shall be select grade hardwood veneer, selected and matched to assure proper balance and consistency.
3. Joints and chassis must be fastened by screws, glue, and heavy-duty metal fasteners. All fasteners shall be concealed.
4. All drawer fronts must be a minimum three-ply construction. Drawer slides must be full extension with steel ball bearing file drawer suspension.
5. Box drawers shall hold a minimum of 50 lbs. File drawers shall hold a minimum of 100 lbs. for 24-30" deep drawers, and 130 lbs. for 36" deep drawers.
6. All desks must have the option to include grommets for wire management.
7. All desks and other table types must have ¾ or full modesty panels.
8. Glides shall be countersunk into hardwood edge at bottom of desk panel and consist of countersunk threaded metal sleeve and adjustable threaded metal glide.
9. Coordination Storage:
  1. Storage cabinets and lateral files shall have capability of being keyed alike.
  2. Master keys shall be provided.
  3. Vertical filing cabinets shall not be used.
  4. Lateral Files
    1. Width shall be 30", 36" or 42".
    2. Depths shall be 18", 20" or 24".
    3. Maximum height shall be 4 drawers.
    4. Dual sided metal locking system that shall lock all drawers simultaneously.
    5. Drawer slides shall be of steel construction with carburized steel ball-bearings.

10. Approved Manufacturers (or equals):
  1. Kimball
  2. National
  3. Indiana
  4. OFS
  5. Gunlocke
  6. DarRan

**E2013 Blinds & Other Window Treatment**

- A. All exterior windows shall have window treatments limited to horizontal metal blinds or specialty shades.
- B. Horizontal metal blinds approved manufacturers:
  1. Hunter Douglas
  2. Levelor
  3. Bali
- C. Specialty shades approved manufacturers:
  1. Mecho
  2. Draper
  3. Hunter Douglas

**E2015 Fixed Multiple Seating**

- A. Fixed Seating
  1. Seats shall be minimum 20" wide.
  2. Seats shall be numbered as specified by University Project Manager.
  3. Foam seat shall be minimum 3" thick.
  4. Chairs must be constructed with polypropylene backs and shell. The inside of the back and seats must be foam covered in fabric or vinyl.
  5. The minimum requirements for tablet arms are as follows:
    1. Must adequately fit a 13"-16" laptop computer.
    2. Must be available right and left-handed.
    3. HPL or vinyl clad top.
    4. Vinyl edge.

**E2020 Moveable Furnishings****E2022 Furniture & Accessories**

- A. System Furniture Panels
  1. The connection system shall be metal-to-metal.
  2. All panel connections shall be such that light passage and electrical wiring are concealed.
  3. The system must feature replaceable exterior surface skins or tiles that can be replaced in the field.
  4. Individual workstation changes shall be capable of being made without disruption to adjoining workstations.
  5. The system shall allow for selective placement of surface finish options.

6. Fabric surface panels shall be tackable.
  7. The system shall have wood veneer trim or painted metal top caps and end caps.
  8. Panels shall have the ability to stack up and/or down in the field.
- B. System Furniture Electrical and Lighting
1. A licensed electrician shall wire system furniture system base feed to building power system.
  2. A minimum of three-circuit, eight-wire power system shall be provided.
  3. Separate data and telecommunication raceways shall be provided.
  4. Raceway covers shall be securely hinged.
  5. Panel system shall be capable of adding or removing baseline or beltline power in the field without dismantling the system.
  6. Task lights shall be LED.
  7. Task lights shall have a minimum 6-foot cord and an on/off rocker switch.
- C. System Furniture Work Surface
1. Maximum unsupported length of work surface shall be 5'.
  2. A 7/8"-1" gap at the back of the freestanding or wall supported work surface or provide grommets or cutouts to allow electrical cords to drop through to cable management components.
  3. Panel mounted surfaces shall have a capacity of 31.5 psf.
  4. Access to work surface wire management should run the entire length of the back edge of all work surfaces regardless of its being panel mounted, wall mounted, or freestanding.
- D. System Furniture Pedestals – Refer to Steel Storage
- E. System Furniture Overhead Furniture
1. Shall attach to either the panels or the walls (using wall track system).
  2. Minimum 22 gauge steel construction.
  3. Provide an anti-dislodgment mechanism on all overhead units.
  4. The overhead doors shall open “up and over.”
  5. The load limit for any overhead storage unit or shelf shall be 150 pounds.
  6. Shall be lockable and have the ability to be keyed alike.
  7. All overheads shall be capable of incorporating a task light with enclosed vertical cord manager.
  8. Approved Manufacturers (or equals):
    1. Steelcase
    2. Allsteel
    3. Haworth
    4. Herman Miller
    5. Kimball
    6. Knoll
- F. System Furniture Keyboard Trays
1. Fully articulating with palm rest
  2. Shall include reversible mouse support and wrist support.

3. Approved Manufacturers (or equals):
  1. Humanscale
  2. Herman Miller
  3. Steelcase
  4. ESI
  5. Knoll
- G. Lounge Furniture
  1. Lounge seating fabric covering shall be Crypton or Nanotex finish or approved equal. Minimum 75,000 double rubs using Wyzenbeek method.
  2. Approved Manufacturers (or equals):
    1. KI
    2. Integra
    3. Arcadia
    4. National
    5. Coalesse
    6. Carolina
    7. Herman Miller
    8. Allsteel
    9. OFS Brands
  3. If lounge chairs are specified with integral tablet arms, the tablet arm shall have a minimum weight capacity of 300 pounds – solid surface is preferred for student facing spaces.
  4. Occasional tables shall be matched to the lounge furniture.
- H. Lounge Side Chairs
  1. Wood or steel frame.
  2. Shall have option for padded seat and/or back.
  3. Shall have minimum 300 pound capacity.
  4. Chair glides shall be specified according to type of floor.
  5. Approved Manufacturers (or equals):
    1. Indiana
    2. Steelcase
    3. National
    4. Highmark
    5. SitOnIt
    6. Haworth
    7. Allsteel
    8. OFS Brands
- I. Stacking or Nesting Chairs
  1. High density stackers or flip/nest.
  2. Weight capacity minimum of 300 lbs.
  3. Any high-density stacking chairs must have polypropylene back and seat and tubular steel frame.
  4. Training room fabric chair coverings shall be Crypton or Nanotex finish or approved equal. Minimum 75,000 double rubs using Wyzenbeek method.
  5. Chair glides shall be specified according to the type of floor.

6. Approved Manufacturers (or equals):
  1. KI
  2. SitOnIt
  3. Highmark
  4. Herman Miller
  5. Haworth
  6. Knoll
- J. Classroom Furnishings Tables and Desks
  1. Horizontal surfaces shall be high pressure laminate (HPL). Surface substrate shall be medium density fiber board (MDF), particle board, or wheat board and must have a minimum density of 45 lb. per cubic ft. All horizontal surfaces shall be constructed to be dimensionally stable and shall be a minimum 1¼" thick.
  2. Flat PVC or vinyl edge. Knife edge or self-edge is unacceptable.
  3. Minimum 18" deep, maximum 30" deep.
  4. Height shall be 29"-30".
  5. For 60" wide tables, maximum seating capacity is 2; for 84" wide tables, maximum seating capacity is 3.
  6. Steel base.
  7. Glides or locking casters.
  8. Approved Manufacturers (or equals):
    1. KI
    2. Coalesse
    3. Berco
    4. Haworth
    5. Versteel
- K. Classroom Seating
  1. High density stackers, sled base, four-legged, flip/nest, task seating.
  2. Weight capacity minimum of 300 lbs.
  3. No arms.
  4. Classroom chair coverings shall be Crypton or Nanotex finish or approved equal. Minimum 75,000 double rubs using Wyzenbeek method.
  5. Casters shall be specified according to type of floor.
  6. Approved Manufacturers (or equals):
    1. SitOnIt
    2. Global
    3. Highmark
- L. Classroom Tablet Armchairs
  1. Must adequately fit a 13"-16" laptop computer.
  2. Must be available right and left-handed.
  3. HPL or vinyl clad top.
  4. Vinyl edge.
- M. Computer Furnishings
  1. Horizontal surfaces shall be high pressure laminate (HPL). Surface substrate shall be medium density fiber board (MDF), particle board, or wheat board and must have a minimum density of 45 lb. per cubic foot. All horizontal

- surfaces shall be constructed to be dimensionally stable and shall be a minimum 1¼” thick.
2. Flat PVC or vinyl edge.
  3. Minimum 18” deep, maximum 30” deep.
  4. Height shall be 29”-30”.
  5. For 60” wide tables, maximum seating capacity is 2; for 84” wide tables, maximum seating capacity is 3.
  6. Steel base.
  7. Power infeed shall be capable of either hardwire or single circuit plug-in.
  8. Two duplex receptacles per table for widths over 36”.
  9. Electrical components (receptacles, lighting, etc.) shall be serviceable and allow for the replacement of individual components.
  10. Table-to-table power connectors available for a variety of table widths.
  11. Power wireway shall provide for separation of electrical and data channels.
  12. Pop-up receptacle modules should be provided as an option.
  13. Grommets and wire managers shall be available as an option.
  14. CPU holders and keyboard trays should be provided as an option.
  15. Approved Manufacturers (or equals):
    1. KI
    2. Haworth
    3. Coalesse
    4. Versteel
- N. Computer Lab Seating
1. Sled base, four-legged, flip/nest, task seating.
  2. Weight capacity minimum of 300 lbs.
  3. With or without arms .
  4. Computer lab chair coverings shall be Crypton or Nanotex finish or approved equal. Minimum 75,000 double rubs using Wyzenbeek method.
  5. Approved Manufacturers (or equals):
    1. SitOnIt
    2. Steelcase
    3. Versteel
    4. Haworth
    5. Highmark
- O. Conference Tables
1. Veneer or HPL tops, solid surface or stone equal may be approved where appropriate.
  2. Wood, flat PVC, or vinyl edge, minimum 1.5” overall thickness.
  3. Height shall be 29”-30”.
  4. Power/data capabilities shall be an option with grommets and wire managers.

5. Approved Manufacturers (or equals):
  1. Kimball
  2. National
  3. Indiana
  4. Coalesse
  5. Herman Miller
  6. Nucraft
- P. Conference Seating
  1. Weight capacity minimum of 300 lbs.
  2. Minimum seat width shall be 22”.
  3. Pneumatic height adjustable.
  4. 5-star swivel base with dual wheel casters.
  5. Base understructure shall be steel.
  6. Upholstered seat with high density foam.
  7. Chairs shall be either fully upholstered or mesh back.
  8. Upholstery shall be Crypton or Nanotex finish or approved equal. Minimum 75,000 double rubs using Wyzenbeek method.
  9. Approved Manufacturers (or equals):
    1. National
    2. SitOnIt
    3. Herman Miller
    4. Keilhauer
    5. Allseating
    6. Steelcase
- Q. Meeting Room Tables:
  1. HPL tops.
  2. Wood, flat PVC, or vinyl edge, minimum 1.25” overall thickness.
  3. Height shall be 29-30”.
  4. Approved Manufacturers (or equals):
    1. KI
    2. National
    3. Indiana
    4. Herman Miller
    5. Versteel
- R. Meeting Room Seating
  1. Weight capacity minimum of 300 lbs.
  2. Minimum seat width shall be 22”.
  3. Base understructure shall be steel.
  4. Upholstered seat.
  5. Upholstery shall be Crypton or Nanotex finish or approved equal. Minimum 75,000 double rubs using Wyzenbeek method.

6. Approved Manufacturers (or equals):
  1. National
  2. SitOnIt
  3. Herman Miller
  4. KI
  5. Steelcase
- S. Break Room Tables
  1. HPL or metal tops.
  2. Flat PVC or vinyl edge, minimum 1.25" overall thickness.
  3. Minimum 30" deep/diameter.
  4. Height shall be 29"-42".
  5. Rectangular tables
    1. 60" wide rectangular tables, maximum seating capacity is 2 per side.
    2. 84" wide rectangular tables, maximum seating capacity is 3 per side.
  6. Circular tables
    1. 36" diameter tables, maximum seating capacity is 4.
    2. 48" diameter tables, maximum seating capacity is 5.
    3. 60" diameter tables, maximum seating capacity is 6.
  7. Square tables
    1. 30" or 36" square tables, maximum capacity is 4.
  8. Steel base.
  9. Approved Manufacturers (or equals):
    1. KI
    2. Berco
    3. Versteel
    4. National
- T. Break Room Seating
  1. Stackable.
  2. Polypropylene back and seat .
  3. Tubular steel frame.
  4. Chairs with flex back option are acceptable.
  5. Chair glides shall be specified according to type of floor (i.e. poly glides for VCT).
  6. Approved Manufacturers (or equals):
    1. KI
    2. Steelcase
    3. SitOnIt
    4. Haworth
- U. Steel Storage
  1. Minimum 22 gauge steel finished in baked enamel.
  2. Storage cabinets and lateral files shall have the capability of being keyed-alike.
  3. Master keys shall be provided.
  4. Vertical filing cabinets shall not be used.

5. Lateral Files:
    1. Widths shall be 30", 36" or 42".
    2. Depths shall be 18".
    3. Maximum height shall be 5 drawers.
    4. Dual sided metal locking system that shall lock all drawers simultaneously.
    5. Drawer slides shall be of steel construction with carburized steel ball-bearings.
  6. Approved Manufacturers (or equals):
    1. Steelcase
    2. Herman Miller
    3. Knoll
    4. Haworth
    5. Great Openings
- V. Steel Storage Cabinets
1. Widths shall be 30", 36" or 42".
  2. Depths shall be 18" or 24".
  3. Heights shall be 28" to 84" maintaining required clearance for sprinkler system.
  4. Dual sided metal locking system that shall lock all drawers/doors simultaneously.
  5. Approved Manufacturers (or equals):
    1. Steelcase
    2. Herman Miller
    3. Knoll
    4. Haworth
    5. Great Openings
- W. Steel Storage Drawer Pedestals
1. Depths shall be 20"-30".
  2. Metal locking system that shall lock all drawers simultaneously.
  3. Shall have full extension drawers.
  4. Approved Manufacturers (or equals):
    1. Steelcase
    2. Herman Miller
    3. Knoll
    4. Haworth
    5. Great Openings
- X. Task Seating
1. Minimum requirements:
    1. Adjustable height arms.
    2. Pneumatic adjustable height seat.
    3. High-density foam seat cushion.
    4. Seat fabric shall be Crypton, Nanotex, or approved equal. Minimum 75,000 double rubs using Wyzenbeek method.
    5. Mesh or upholstered back.
    6. Adjustable lumbar support.

7. Tilt lock mechanism.
8. Hard and soft casters shall be available. Casters shall be verified according to flooring type.
9. Five star base with dual wheel casters.
2. Approved Manufacturers (or equals):
  1. Steelcase
  2. Highmark
  3. SitOnIt
  4. Allseating
  5. Knoll
  6. Herman Miller
  7. Haworth
  8. National

**Document Revision History**

Version	Section	Summary of Change	Date



## 2025 Section G – Sitework

### INDEX

G10	Site Preparation
G20	Site Improvements
G30	Site Mechanical Utilities
G40	Electrical Site Improvements (Utilities)
Document Revision History	

### LINKED DOCUMENTS

<a href="#">G10 – Site Preparation</a>
<a href="#">G20 – Site Improvements</a>
<a href="#">G30 – Site Mechanical Utilities</a>
<a href="#">Appendix G1</a>

**G Sitework****G10 Site Preparation****G1010 Site Clearing**

## G1011 Clearing and Grubbing

- A. Debris resulting from stripping and clearing operations shall be promptly removed from University property.

## G1012 Tree Preservation

- A. [Tree Removal and Trimming, Selective Trimming](#)
- B. Refer to the [Landscape Master Plan](#) for the preferred and prohibited species list.

**G1020 Site Demolition and Relocation**

## G1022 Demolition of Site Components

- A. Demolition shall remove all parts of a building, including foundations, and all associated underground utilities.
- B. The demolition plan shall indicate requirements for control of dust and noise mitigation.

**G1030 Site Earthwork**

## G1031 Site Grading Excavation

- A. Finish grade slopes shall be shallow enough to allow mowing and maintenance (generally 3:1 or less).

## G1032 Borrow Fill

- A. Specify project specific earthwork and compaction requirements based upon recommendations from the geotechnical investigation.
- B. Projects not obtaining a new geotechnical investigation shall coordinate compaction requirements with the UPL for site specific compaction requirements.

## G1033 Soil Stabilization &amp; Treatment

- A. All project-disturbed land (regardless of size) shall be designed to reduce erosion and sedimentation impacts through appropriate Best Management Practices (BMPs) per the latest edition of the Alabama Handbook for Erosion Control, Sediment Control and Stormwater Management of Construction Sites and Urban Areas by the Alabama Department of Environmental Management (ADEM).
- B. Post construction stormwater requirements shall be implemented in projects that increase impervious surface so that development will mimic pre-development

hydrology as described in the Auburn University Post Construction Stormwater Manual.

G1037 Erosion Control

- A. Except where the Auburn University Design and Construction Standards are more stringent, design shall comply with The Alabama Handbook for Erosion and Sediment Control and Storm Water Management of Construction Sites and Urban Areas.
- B. The Erosion and Sediment Control Plan shall be prepared by a Qualified Credentialed Professional (QCP) as defined by ADEM.
- C. The Design Return Period Storm for sizing Erosion and Sediment Control Measures shall be a 5-year, 24-hour storm.
- D. Before initiating any earthwork not directly associated with the installation of erosion and sediment control measures as indicated on the pre-construction erosion control plan, the Contractor shall submit a Land Disturbance Authorization form obtained from the University Project Lead.
- E. Unless notified by the UPL, the Contractor shall be responsible for obtaining a Notice of Registration (NOR) from ADEM and providing all necessary inspections and corrective measures during construction. The Contractor shall provide proof of ADEM registration to the UPL prior to receiving the Land Disturbance Authorization permit.
- F. At the discretion of the UPL, turbidity monitoring will be implemented by the Owner under the following guidelines:
  1. Project sites that discharge directly to an open channel or stormwater conveyance.
  2. Project sites where 0.5 acres or greater of disturbance is anticipated.
  3. Sampling shall occur monthly or within 24 hours of any storm event greater than 0.5”.
  4. Sampling locations should include site discharge point and upstream and downstream sample locations as determined in Design Phase.
  5. Where upstream and downstream monitoring is implemented, any increase in turbidity shall be no more than 50 Nephelometric Turbidity Units (NTUs)
- G. ADEM shall be notified by the Owner if any sites are found to be non-compliant during inspections with the Contractor being responsible for any regulatory fines incurred throughout the course of construction.
- H. Erosion and Sediment Control Plan (ESCP)
  1. The Erosion and Sediment Control Plan is a set of drawings which provides the necessary measures to reduce erosion on construction sites and minimize the impacts of sediment, turbidity, and hydrologic changes off-site throughout the life of the project and beyond. It is to ensure that erosion and sediment control is appropriate for the planned use of the site.
  2. The ESCP shall be designed as a three-phase plan to include the following:
    1. Phase 1: Pre-Construction Site Plan Drawing - This plan to show necessary erosion sediment control measures to be installed before land disturbance authorization is granted. Only grading specifically identified

- as intended for erosion and sediment control shall be permitted prior to land disturbance authorization.
2. Phase 2: Construction Site Plan Drawing
  3. Phase 3: Post-Construction Site Plan Drawing - Note: This plan to show necessary Erosion Sediment Control Measures to be installed before substantial completion to be awarded.
- I. Silt Fence (SF)
1. All silt fence shall be installed in 2 parallel rows, 2' apart at project boundary.
  2. Type A silt fence is the standard silt fence utilized by Auburn University.
  3. Type A is used in locations of high flow and is supported by wire reinforcement.
  4. Type A silt fence is reinforced galvanized steel of the following dimensions:
    1. 12 gauge "hog wire" with small openings oriented at the base of the silt fence.
    2. 14 gauge 4"x4" wire mesh size, W1.4/1.4

## **G1040 Hazardous Waste Remediation**

### **G1042 Soil Restoration and Treatment**

- A. Hazardous materials survey and remediation are assumed to be separate from building design unless otherwise requested by the University Project Lead and/or Risk Management and Safety.
- B. Auburn University will contract directly with environmental consultants to perform the necessary assessments and remediation, if applicable. The consultant retained for such services must be a professional engineer with current registration in the State of Alabama in addition to any certifications required by local, state, and federal regulatory agencies.

## **G20 Site Improvements**

### **G2010 Roadways**

- A. Fire apparatus access roads shall be included in the design, taking into consideration buildings surrounding the project site.

### **G2012 Paving & Surfacing**

- A. Roadways and Parking Lots
1. Provide pavement specifications that reflect Alabama Department of Transportation (ALDOT) standard pavement mix design as appropriate for specific soil conditions and anticipated loading.
  2. Street and parking lot layouts shall comply with Manual on Uniform Traffic Control Devices (MUTCD). Parking space shall be 9' wide and 18' deep.
  3. Routes to ADA accessible locations (i.e., accessible parking, drop-off locations, accessible routes building entrances, etc.) shall be maintained or alternate routes shall be provided.

- B. Permanent and temporary traffic regulatory signage and pavement markings shall meet the requirements of MUTCD.
- C. All signage shall comply with the Auburn University Sign & Wayfinding Program Manual
- D. Pavement markings shall be as follows:

	Non-reflective traffic rated paint	Thermoplastic, Class 2, Type A per ALDOT Specifications
Campus Roads		X
Parking Lots	X	

**G2030 Pedestrian Paving**

G2031 Paving & Surfacing

- A. Typical width shall be 6’ for minor walks and 8’ for major walks.
- B. An accessible route must be provided outside of the construction site.
- C. Selection of paving material shall be based on all of the following criteria:
  - 1. [Landscape Master Plan](#)
  - 2. Existing paving material in the vicinity.
  - 3. Maintenance and durability.
- D. Concrete Walks
  - 1. Minimum of 6” thick with 6x6 welded wire fabric over 6” of compacted gravel base over a compacted soil sub-base.
  - 2. Subgrade conditions must be considered during design of walks.
  - 3. Light broom finish perpendicular to traffic flow.
  - 4. Joints shall be tooled.
  - 5. No fibrous mesh.
  - 6. No stamped or patterned concrete.
  - 7. One of the coloring agents described below shall be mixed into the concrete at the batch plant. Both mixes begin with 4000psi concrete with a 3” slump.
    - 1. Synthetic Pigment: Medium Alabama Ochre at 12.5 lbs. per yard, by Alabama Pigments Company, conforming to ASTM C979, synthetic mineral-oxide or water reducing admixtures, color stable, free of carbon black, non-fading, and resistant to lime and other alkalis.
    - 2. Natural Pigment: Ochre #548 at 37.5 lbs. per yard, by Southern Color or New Riverside in Cartersville, Georgia.
    - 3. Exceptions for omitting coloring agent to match existing must be approved by the University Project Lead.
  - 8. Joint sealants
    - 1. Sealant color shall match the surrounding concrete.
    - 2. For Ochre colored concrete use BASF “Saltbox” or equivalent.

- E. Bituminous Walks
  - 1. Utilize an ALDOT approved mix for light-duty traffic.
  - 2. Typical bituminous walks shall be a full 2" compacted thickness (220 lbs. per square yard wearing course asphalt) on a 4" compacted gravel base.
  - 3. The base and the bituminous material shall each be compacted to 98% of their test densities.
- F. Masonry Pavers
  - 1. Clay Brick Pavers
    - 1. Impervious pavers.
    - 2. Pavers to be installed on bedding sand on top of 6" concrete slab meeting requirements of concrete walk.
    - 3. Polymeric sand to be used to stabilize joints.
    - 4. Primary Paver – 4"x8" Heavy Vehicular paver English Edge Full Range by Pine Hall Brick.
    - 5. Secondary Paver – 4"x8" Heavy Vehicular paver Georgian Edge Buff by Pine Hall Brick.
  - 2. Detectable Warning Paver – 4"x8" Heavy Vehicular Truncated Dome paver Pathway Red by Pine Hall Brick.
  - 3. Pervious Pavers
    - 1. Pavers shall be installed on pervious stone base per manufacturer recommendations.
    - 2. Primary Pervious Paver – 2¼" thick StormPave permeable paver Full Range by Pine Hall Brick.
  - 4. When a curb ramp is built on one side of a street, a companion ramp is required on the opposite side of the street. When project limits would normally end within a street intersection, the limits must be extended to allow construction of a companion ramp on the opposite side of the intersection.

## G2040 Site Development

- A. Structural Steel
  - 1. All structural steel in exterior locations (such as cornices, parapets, handrails, guard rails, or canopies) shall be hot dip galvanized steel and powder coated Auburn Bronze.
    - 1. [Auburn University Color Standards](#)

## G2041 Fences and Gates

- A. Fencing shall be in accordance with the [Landscape Master Plan](#).
- B. Landscape Master Plan.
- C. Bollards:
  - 1. Fixed:
    - 1. 6" Ø x 48", 11-gauge steel.
    - 2. Concrete filled, rounded top set in concrete footing.
    - 3. 2' above grade.
    - 4. Maximum spacing: 66" o.c.

5. Painted Deep Bronze (Matthews MP37092-R105749).
  1. [Auburn University Color Standards](#)
2. Removable & Locking:
  1. 6" x 30" removable section (24" above grade).
  2. 8" x 32" sleeve insert in concrete footing.
  3. Top of insert shall be removable and set flush with grade.
  4. Maximum gap on insert for upper section: 3/8"
  5. Powder coated Deep Bronze (Matthews MP37092-R105749).
  6. 3" wide yellow reflective stripe around top.
  7. With locking pin with tabs for padlock.
- D. Post and Chain:
  1. Post:
    1. 3" dia. x 60", 11-gauge tube.
    2. 36" above grade, set in concrete footing.
    3. Capped with cast iron bollard cap (Orleans Ornamental No. 9539) or equal welded to tube.
    4. Provide 1/4" Ø and 3/8" through holes for chain and securing bolt.
    5. Powder coated Deep Bronze (Matthews MP37092-R105749) after fabrication.
  2. Chain:
    1. 5/16" galvanized chain
    2. Secured to post with 5/16" bolt with lock washer and nut .
    3. Painted Deep Bronze (Matthews MP37092-R105749).

#### G2042 Retaining Walls

- A. Retaining walls shall be cast in place concrete and constructed with vertical drainage system behind the wall with an outlet pipe connected to the storm drainage system, or with a direct outlet to a drainage channel.
- B. Drainage pipe shall include wrapping the pipe with filter fabric sock and careful bedding of the pipe with appropriate fill material.
- C. Weep holes as a means of drainage for retaining wall systems are not to be used without prior approval.
- D. All exposed concrete shall be brick veneered or colored to match the concrete sidewalk requirements.

#### G2045 Site Furnishings

- A. Bicycle Racks
  1. "Campus Rack" by the DERO Bike Rack Company. Color: Statuary Bronze Powder Coat.
  2. Surface mounted on concrete pad or brick pavers.

3. Bicycle racks shall be installed at the following ratios:
  1. Residence Halls: One bicycle stall for every four beds.
  2. Covered bicycle parking coordinated with adjacent building architecture to be provided at residence halls.
  3. Classroom Buildings: One bicycle stall for every eight occupants plus six stalls.
  4. Office/Administrative Buildings: One bicycle stall for every twenty occupants plus six stalls.
- B. Site Seating
  1. Fixed Furnishings
    1. Benches
      1. All benches to be surface mounted to concrete or brick paver pad.
      2. Campus Standard Bench - Bronze Steelsites Series Model RB-28 by Victor Stanley.
    2. Tables and Chairs
      1. Fixed tables and chairs to be surface mounted to concrete or brick paver pad.
      2. Provide ADA compliant seating.
      3. Campus Standard Table and Chair – Stormcloud 35 Collection Mingle Seating by Landscape Forms.
  1. Loose Furnishings
    1. Trash and Recycling
      1. Waste and Recycling Receptacles – Victor Stanley Steelsites Series Model RB-36 powder coated VS Bronze. Provide labeling bands.
      2. Waste and Recycling Compactor – Solar powered Big Belly compacting receptacle.
  - D. Trash and Recycling Dumpsters
    1. For new buildings, provide a standard outdoor service area to place 3-6 recycling 95-gallon carts, a cardboard recycling dumpster, and at least one trash dumpster.
    2. High volume areas (i.e., dining venues, residence halls, etc.) may require more than one trash dumpster, cardboard recycling dumpster, other waste and recycling equipment (i.e. compactor, baler, etc.), towable carts for cardboard and trash, additional 95-gallon carts, or containers for other waste (i.e. grease, food waste, animal bedding, etc.).
    3. Locations shall reduce the visual impact of trash and recycling dumpsters and equipment.
    4. Dumpster enclosures shall be located in close proximity to the service dock of each building.
    5. Paved access for staff to deposit waste and vehicle access by a front load refuse truck (or service vehicle determined by the University Project Lead) shall be considered in the location. Provide turnaround route or access

without creating a traffic hazard. Allow for overhead clearance of 25' at the loading point.

6. Masonry, wood, or plant screening wall shall be provided for each location.
7. Front end load dumpsters shall be used where space permits.
8. Dumpster Pad:
  1. A reinforced concrete pad shall be installed under and in front of each dumpster to prevent damage from the front wheels of the service vehicle.
  2. A minimum of dumpster width plus 6' x 15' shall be allotted for each front end load dumpster. The same area requirements shall be allotted for cardboard recycling dumpsters.
  3. Shall extend 6' in front of any trash or recycle container.
  4. [Trash and Recycling Area Minimum Requirements](#)
9. Provide heavy duty grade paving for the route that the refuse truck will take to service the dumpsters.
10. Provide signage and striping to ensure adequate access to waste and recycling area.
11. Connect surface drains for trash compactor pads to sanitary sewer.

#### **G2050 Landscaping**

- A. Landscaping and plant materials shall be warranted for one year from Substantial Completion unless otherwise specified.

#### **G2054 Seeding and Sodding**

- A. Lawns
  1. Permanent lawns shall be sodded. Seeding is allowed only for temporary purposes.
  2. The areas to be grassed shall be held down 4" below finished grade prior to sodding.
  3. Sodded grasses shall be:
    1. Tifway 419 Bermudagrass
    2. Emerald Zoysiagrass
    3. Meyer Zoysiagrass
    4. Celebration Bermudagrass
  4. Fertilizer shall be a commercial fertilizer delivered in unopened original containers each bearing the manufacturer's guaranteed analysis. Any fertilizer which comes caked or otherwise damaged shall not be accepted. Fertilizer selection and application rate shall be determined by soil analysis. Lime shall be granulated agricultural limestone applied at a rate according to soil sample analysis. Apply fertilizer uniformly at specified rate with an approved distributor prior to seeding. Fertilizer shall be worked into the top 3 to 4" of the soil.
  5. Mulch for seeded areas shall be weed-free grain straw. Quantity shall be 3,300 pounds per acre (approximately 75 pounds per 1000 SF) or 65 bales per acre (1½ bales per 1000 SF)

6. Cultivation average shall be a 4" deep layer of topsoil after scarification to a depth of 6" minimum. Pulverize the soil with a roller type pulverizer with 4" tines. Hand rake the soil to level and remove loose stones and other debris leaving a smooth friable condition suitable for sodding
  7. All seeding shall be conducted with moist but not wet soil and broadcasted by means which will ensure uniform distribution and thorough coverage of the entire area. Areas which do not show a prompt "catch" or have been washed shall be reseeded for thorough coverage.
- B. Maintenance
1. Installed landscaping shall be maintained until final acceptance of the landscaping.
  2. Sodded areas shall be sufficiently irrigated to maintain a continually moist condition.
  3. Mowing operations shall be conducted to keep the lawn in a neat and well-groomed appearance. The lawn shall only be cut when grass and soil are dry. Not more than 1/3 of the total leaf surface is to be removed at one mowing. It is not necessary to remove clippings if grass is mowed according to these specifications.
  4. General maintenance by the Owner, after final acceptance, shall not void the warranty.
  5. Soil analysis, seed and fertilizer data, and instructions for planting and care of the lawn shall be submitted to the University Project Lead.
  6. Warranty: Sod shall be warranted for six months after final acceptance of landscaping at Substantial Completion.

#### G2057 Irrigation Systems

- A. Irrigation systems shall be designed to minimize potable water use.
- B. All fixed irrigation systems shall fully and seamlessly integrate with the current networked irrigation control system. System shall have the following capabilities at a minimum:
  1. Web based water management software.
  2. Advanced flow management capability.
  3. Weather monitoring devices.
  4. Flexible communication options.
  5. Moisture sensing capability.
- C. Irrigation controllers shall be grounded according to the manufacturer's specifications.
- D. Drip irrigation to be installed in all shrub, annual, perennial, and tree areas of the landscape. Drip irrigation shall be staked to stable ground every 4'.
- E. Gear driven rotor sprinklers shall be installed in all turf areas. Type of head depends on sprinkler head spacing.
- F. Sprinkler head spacing of 35-60' use large rotor with swing arm such as Rainbird Falcon, Stainless Steel or approved equivalent.
- G. Sprinkler head spacing of 20-35' use Hunter I-20 with flex pipe, or approved equivalent.

- H. Sprinkler head spacing of less than 20' use spray head such as Rainbird 1806 Sam or approved equivalent.
- I. All sprinkler heads must have a check valve to prevent line drainage.
- J. Nozzle selection must utilize Matched Precipitation Rates
- K. Main isolation valves shall be full port brass ball valve inside a valve vault with a double check backflow preventer.
- L. Master valves:
  - 1. Shall be installed after the backflow prevention consisting of a normally open valve sized according to design flow.
  - 2. Electrically operated with a minimum of #14 AWG for conventional wire or appropriately sized per manufacturer specifications for two wire.
  - 3. Brass construction.
  - 4. Buckner/Superior or approved equivalent.
- M. Irrigation flow meters shall be installed after the master valve. Flow meters are to be sized according to the required design flow. Flow meter must have the capability to communicate with the irrigation system.
- N. Brass quick-connect hose bibs shall be 1" Rainbird 55k or approved equivalent and placed on the irrigation main line. Bibs should be placed around the site such that ALL the landscape can be watered via hoses of maximum length of 100'. These quick-connect hose bibs should be located DOWNSTREAM of a non-return water meter and double-check valve backflow preventer and UPSTREAM of any irrigation station valve. These quick connect hose-bibs are required of ALL projects, even ones that have automatic irrigation systems.
- O. Valves shall be installed in a minimum of a 12" heavy duty commercial grade rectangle valve box such as Carson or approved equivalent.
- P. Wire junctions shall be installed in a 10" round valve box with waterproof connectors.
- Q. All field wires shall be a minimum #14AWG rated for underground use or a minimum of #12, double jacketed two-wire.
- R. Provide minimum 6" PVC sleeves under roadways, walkways, (hardscape) to accommodate installation of sprinkler system piping and wiring. Provide stamped indicator where sleeve traverses hardscape to allow for quick identification and location of sleeves.
- S. All irrigation piping shall be installed with a #14 copper tracer wire.
- T. Water service to irrigation system shall have a utility isolation valve upstream of a non-return water meter (provided by Auburn University), meter bypass, and a back flow preventer. Irrigation meter shall be separate from the building water service.

### **G30 Site Mechanical Utilities**

- A. Buried Piping
  - 1. Domestic water, chilled water, and fire lines shall be above other utilities in crossings.
  - 2. Provide a minimum of 18" vertical and horizontal clearance between utilities.
- B. Backfill

1. Do not backfill utility trenches until approved by the University Project Manager.
  2. See [Bedding and Backfill Table](#) for specifications based on utility system and trench characteristics.
  3. At utility crossings, backfill material should be #57 stone to a depth of 12" above the highest pipe.
  4. When soil is the appropriate backfill, use soil that can be smoothly dressed to match the surface of the ground adjoining the edges of the trench, and that will support the vegetation desired for the finished surface.
- C. Above Ground Utility Appurtenances
1. Shall be 1" above the landscaped surface in planting beds.
  2. Shall be flush to 1" below the landscaped surface in lawn areas.
- D. General Utility Testing Requirements
1. The University Project Lead shall be notified a minimum of 48 hours prior to any testing.
  2. The results of all tests shall be provided to the Designer and the University Project Lead.
- E. Documentation
1. Upon completion of site utility work, survey grade as-builts shall be provided by the contractor including boring coordinates of trenchless installed utilities.

## **G3010 Water Supply**

### G3011 Potable Water Distribution

- A. Piping & Fittings
1. See [Piping and Fittings Table](#) for specifications.
  2. See [Piping Joints Table](#) for specifications.
  3. See [Bedding and Backfill Table](#) for specifications.
  4. All mechanical joint fittings requiring thrust blocks shall be wrapped in plastic prior to installation of concrete.
- B. Valves
1. See [Valve Table](#) for specifications.
  2. All service lines off the main shall have an isolation valve.
  3. All 2" or larger service lines must include a tri-valve arrangement at the main.
  4. All valves and valve extensions shall terminate within 2 feet of finished grade.
  5. A valve jar shall be provided from valve housing to finish grade.
  6. Valves installed above grade shall have hand wheels.
- C. Backflow Preventers
1. See [Specialty Device Table](#) for specifications.
  2. Backflow prevention devices shall be Double Check or Reduced Pressure Zone type. Double Checks are the University's preference for non-high risk plumbing applications. Designers shall use AWWA M14 "Backflow Recommended Practices" for final determination of Double Check or Reduced Pressure Zone backflow preventers.

3. Enclosures for Reduced Pressure Zone backflow preventers installed above grade shall be heated.
  4. Interior RPZ installations shall include a dedicated floor drain near the RPZ's discharge bowl and piping.
  5. Exterior double check backflow preventers should be installed below grade in a meter box or vault.
  6. All non-irrigation and non-fire system backflow preventers shall be installed with a bypass for use during testing.
- D. Inserting Valves
1. See [Specialty Device Table](#) for specifications.
- E. Automatic Air Release Valves:
1. See [Specialty Device Table](#) for specifications.
  2. Automatic air release valves for installation on 24" diameter and smaller ductile iron mains shall be suitable for operating pressures below 150 psi.
  3. The air release valve shall not be placed in service until the water main has been flushed out and all the air has been manually vented through the horizontal bypass valve during water main filling operation.
- F. Valve Jars
1. See [Specialty Device Table](#) for specifications.
  2. Valve jar lid shall be imprinted with "Water" on the top.
  3. Valve jar risers shall be cast iron and shall conform to that of valve jar top section and shall be used in appropriate heights to adapt to changing landscapes.
  4. Valve Boxes shall have a pre-cast concrete collar in landscaped areas and poured-in-place concrete collars in paved areas.
    1. Pre-cast concrete collars shall be 4000 psi with 24" outside diameter with a 10" inside diameter center hole.
    2. Poured-in-place concrete collars shall be 4000 psi 24"x 24" square with inside hole sized to fit valve box.
- G. Meters
1. Meters for services from the AU distribution system shall be provided by Auburn University.
  2. All new meter sets will include automated meter reading (AMR) equipment to be provided and installed by Auburn University Utility Services.
  3. Meter assemblies shall be located inside the building's mechanical room unless otherwise discussed with Auburn University. Design shall include accessible conduit access from the meter to outside of the building to install an AMR device.
  4. Meter assemblies shall include a strainer and locking bypass piping system sufficient to sustain water service during meter and backflow preventer outage.
  5. Exterior installation:
    1. Meter boxes in landscaped areas shall be Black Sigma 1730 with "Auburn University Water" in top.

2. Meter boxes for 1½” and smaller meters shall be high density reinforced concrete meter box with non-settling shoulders with a high-density, RF transparent, plastic lid. Nicor or approved equal.
  3. Meter vaults for 2” and larger meters shall be pre-cast or poured-in-place vaults, which house meter assemblies and backflow prevention valves centered about the vault. Vaults shall have a locking aluminum traffic rated lid.
- H. Testing of Domestic Water Lines
1. See [Domestic Water Line Pressure Testing Requirements](#).
- I. Water Mains and Hydrants Cleaning/Disinfecting
1. See [Domestic Water Line Cleaning and Disinfecting Requirements](#).

#### G3014 Fire Protection Distribution & Storage

- A. General
1. Existing fire hydrants shall be accessible to fire apparatus during construction, alteration and/or demolition.
  2. No fire main shall have any structure, temporary or permanent, built over the top of it unless approved by University Project Lead.
  3. All domestic and fire lines shall be flushed, chlorinated, and tested in compliance with G3011.H and G3011.I.
  4. If a fire flow test is required, the designer shall request the test from the UPL.
- B. Piping & Fittings
1. Provide 4” minimum ductile iron pipe, valves, and fittings.
  2. Water lines supplying fire hydrants shall be a minimum of 6”.
- C. Valves
1. Post Indicator Valves are required on all fire service lines and shall be no less than 40’ from the building.
- D. Hydrants
1. See [Specialty Device Table](#) for specifications.
  2. Fire hydrants shall be no more than 100’ from fire department connection.
  3. All fire hydrant assemblies shall include isolation valves no more than 5’ from fire hydrant.
  4. Review geotechnical report for the presence of impervious soils in the project area. In the event impervious soils are present, a drainage pit 2’ in diameter and 2’ deep shall be excavated below each hydrant and filled compactly with coarse gravel or crushed stone under and around the hydrant foot and to a level 6” above hydrant weep holes.
  5. Hydrant anchoring system is to be designed by the engineer.
  6. Anchoring shall be accomplished by one of the following methods:
    1. EBBA Iron MEGA LUG series for ductile iron or approved equal.
    2. Stainless steel all-thread rod. At a minimum, all-thread rod shall be ¾” diameter, 18-8 stainless steel.
    3. Concrete braces shall be used in all new fire hydrant sets.
    4. Concrete braces shall not block hydrant weep holes.

7. Fire hydrant extensions shall be used to bring hydrants up to grade. Extensions shall be by the same manufacturer as the hydrant. No more than one extension riser per hydrant set.
8. Fire hydrants shall be installed plumb and such that nozzles are approximately 18" above finished grade.
9. Hydrant steamer nozzle connection orientation shall be as determined by Auburn City fire department.
10. Hydrants shall arrive at the job site with a factory coating of silver paint.

### G3020 Sanitary Sewer

#### A. General

1. Designer shall provide verification that existing system capacity is compatible with the current proposed design.
2. Package Pumping/Lift Stations are not allowed.
3. No sanitary sewer manhole, piping, or fittings shall have any structure, temporary or permanent, built over the top of it.
4. All new sanitary sewer lines shall be designed with the following minimum line sizes: Laterals 6" and Mains 8".
5. Maximum length of sanitary sewer laterals shall be 100' from the face of the building. Beyond that distance, laterals shall be considered mains and all rules for sanitary mains shall apply.
6. All new sanitary sewer lines shall be designed such that the velocity of the flow in the pipe shall not be less than 2' per second, nor exceed 10' per second.
7. Sanitary sewer lines shall be a minimum of 18" below potable water lines.
8. Sewer lines and manholes which are no longer in service shall be removed.

### G3021 Piping

#### A. New Piping

1. See [Piping and Fittings Table](#) for specifications.
2. See [Piping Joints Table](#) for specifications.
3. See [Bedding and Backfill Table](#) for specifications.
4. Pipe shall be installed such that the pipe bell is upstream of the pipe spigot.

#### B. Pipe Rehabilitation

1. Rehabilitation of existing sanitary sewer lines and manholes shall be reviewed and approved by Auburn University Distribution System Engineer with final approval from UPL. Acceptable rehabilitation methods include the following:
  1. Cured-In-Place Pipe (CIPP) Lining Systems
    1. Conform to standards from the American Society for Testing and Materials, such as:
      1. ASTM F1216 (Rehabilitation of Existing Pipelines and Conduits by the Inversion and Curing of a Resin-Impregnated Tub)

2. ASTM F1743 (Rehabilitation of Existing Pipelines and Conduits by Pulled-In-Place Installation of Cured-In-Place Thermosetting Resin Pipe (CIPP))
  3. ASTM D5813 (Cured-In-Place Thermosetting Resin Sewer Pipe)
  4. ASTM D790 (Test Methods for Flexural Properties of Un-Reinforced and Reinforced Plastics and Electrical Insulating Materials)
  5. ASTM D2990 (Tensile, Compressive, and Flexural Creep and Creep-Rupture of Plastics).
2. Pipe Bursting (PBM)
    1. The Pipe Bursting process is defined as the reconstruction of gravity sewer pipe by installing an approved pipe material (HDPE), through the alignment of the existing sewer line. Approved process involves the use of a hydraulic "moling" device, pneumatic hammer, or a conical shaped rigid or static bursting head or flared plug of a suitable size to break out the old pipe and simultaneously install a new HDPE pipe of the same or larger host pipe size.
    2. Method used must define process for reconnection of all existing or new sewer service house laterals, watertight sealing at manholes, and reconstruction of manhole inverts.
    3. Television inspection of the new pipeline is required.
    4. The Contractor shall be certified as a fully trained PBM user by the Pipe Bursting System Manufacturer that the Contractor intends to utilize on the job. A copy of certification is required with the bid.
- C. TV Video Inspection
    1. [Inspection Requirements for New Below Grade Sanitary/Storm/Grease/Acid Sewer Pipe](#)
  - D. Low Pressure Air Testing
    1. Refer to [Sanitary Sewer Testing Requirements](#).

## G3022 Manholes and Cleanouts

- A. Manhole Placement
  1. Manholes shall be installed on mains at any location where there is a change in grade or direction of flow.
  2. All building sewer laterals shall connect to the sanitary sewer collection system at a manhole.
  3. Maximum spacing between sanitary manholes shall be 400’.
  4. Turns in manholes that change the direction of flow shall not exceed 90°.
- B. Manhole Connections
  1. Manhole connections for sewer piping smaller than 24” shall be accomplished using flexible connectors.
  2. Manhole connections for sewer piping 24” or larger should be accomplished using mortar comprised of 1 part Portland Type II cement and 2 parts sand by volume.

3. Incoming lines with inverts 24" or higher above the exiting invert shall have an exterior drop connection.
- C. Manhole Construction
  1. See [Sanitary Sewer Manhole Design & Construction Requirements](#).
- D. Manhole Rehabilitation
  1. Cementitious Fiber-Reinforced Structural Monolithic Manhole Lining System to be applied as per the manufacturer's recommendations.

### G3030 Storm Sewer

- A. General
  1. Storm sewers shall be designed for a 25-year design frequency except where crossing roadways which shall be designed for a 50-year frequency.
  2. New development shall provide no increased peak rate of runoff with control of runoff rates for the 2-, 5-, 10-, 25- year (24 hour) storm events to less than or equal to existing and safe passage of 100-year storm volumes.
  3. Water quality treatment shall be provided for the runoff generated by the first 1.2" of rainfall in storm events with goals to promote infiltration of runoff from impervious areas to the maximum extent practical.
  4. Inlet sizing and spacing shall be designed to allow no more than 6' diameter spread around inlets during design rain event.
  5. All new storm sewer lines shall be designed with the following minimum line sizes: 6" laterals and 12" mains.
  6. All new storm sewer lines shall be designed such that the velocity of the flow in the pipe shall not be less than 3.5' per second of full pipe flow velocity, no exceed 15' per second of full pipe flow velocity.
  7. No storm sewer manhole, piping, or fittings shall have any structure, temporary or permanent, built over the top of it.
  8. Remove existing sewer lines and manholes which are no longer in service.
  9. All storm sewer junction boxes shall have an access point from grade.
  10. No conflict boxes will be allowed.

### G3031 Piping

- A. Piping and Fittings
  1. See [Piping and Fittings Table](#) for specifications.
  2. See [Piping Joints Table](#) for specifications.
  3. Pipe shall be installed such that the pipe bell is upstream of the pipe spigot.
  4. For RCP, all pipe lift holes are to be plugged with POPIT, Inc. brand lift hole plugs or approved equal.
- B. TV Video Inspection
  1. [Inspection Requirements for New Below Grade Sanitary/Storm/Grease/Acid Sewer Pipe](#)
- C. New Installation Testing
  1. Contractor shall ensure:
    1. Lines are uniformly bedded and backfilled.
    2. Joints are tight with fully compressed gaskets.

3. No joint opening exceeds  $\frac{1}{4}$ ".
  4. Smooth and uniform interior sections with respect to surfaces, grade, and alignment.
  5. Lines are watertight within allowable limits.
2. All lines shall be tested in accordance with procedures and practices applicable to the various types and kinds of pipe and to the various sizes of pipe. The Contractor is reminded that personnel not experienced in testing procedures and practices, and particularly in air-testing of pipelines, should neither be allowed to conduct the test nor assist in the test procedures. Contractor shall furnish all labor, supervision, materials, and equipment required for testing of sewers.

### G3032 Manholes and Cleanouts

#### A. Manhole Placement

1. Manholes shall be installed on mains at any location where there is a change in grade or direction of flow.
2. All building drainage laterals shall connect to the storm sewer collection system at a manhole, junction box, or inlet box.
3. Maximum spacing between storm sewer manholes shall be 400'.
4. Turns in manholes that change the direction of flow shall not exceed 90°.

#### B. Manhole Connections

1. Manhole connections shall be accomplished using flexible connectors or using mortar comprised of 1 part Portland Type II cement and 2 parts sand by volume.

#### C. Manhole Construction

1. See [Storm Sewer Manhole Design & Construction Requirements](#).

#### D. Cleanouts

1. Provide combination cleanout plug/relief on first cleanout outside of building.
2. Cleanouts shall be installed on laterals at any location where there is a change in grade or direction of flow.
3. All storm sewer wyes shall have a cleanout within one foot of the upstream side of the wye.

### G3033 Headwalls and Catch Basins

#### A. Collections and Catch Basins

1. In locations where leaf clogging of conventional drains would be expected, provide scupper or cast-iron dome type drains.
2. Install removable bars or grills at open ends of culverts, drains, and pipes 10" diameter and larger.
3. Curb inlets along roadways and in parking lots shall be ALDOT Type S self-cleaning inlets. Allowable spread for roadway applications is 6' or  $\frac{1}{2}$  of travel lane width, whichever is less.

4. Gutter downspouts which connect to underground storm system shall utilize a cast iron downspout boot of Barry Pattern & Foundry type B25A or approved equal to transition between downspout and drainage lateral.

#### G3035 Retention Ponds

##### A. Underground Detention

1. All underground detention structures should be constructed on precast concrete vaults, poured in place concrete structures, or reinforced concrete pipe.
2. Multiple barrels of reinforced concrete pipe shall have a manifold at one end with reinforced concrete pipe equal in diameter to the largest pipe barrel used in the detention system, or a junction box larger than the largest pipe barrel used in the detention system.
3. A trash collection structure must be installed upstream of all underground detention structures.
4. All underground detention structures must include an air release structure large enough to prevent air locking during a rain event.
5. All underground detention structures shall have a minimum of 1 standard manhole access point including manhole steps.

#### G3040 Heating Distribution

#### G3043 Hot Water Supply System

##### A. Piping

1. Designer of Record to work with Auburn University Utilities & Energy department for determination of desired piping system for the application.
2. Black Steel Pre-Insulated Pipe
  1. See [Carbon Steel Hot Water Supply Piping and Insulation Specifications](#)
3. Cross-linked polyethylene, Type A (PE-Xa)
  1. Rated for continuous operating temperature of 210°F at 80psi.
  2. Minimum 40-year manufacturer warranty.
  3. Fittings/Joints to be mechanical or electrofusion rated for below-grade applications.
  4. Insulation: Closed Cell Spray Foam, Field Applied.
  5. Tracer Wire: Continuous #10 solid copper rated for underground service. Connect to all valves and underground steel chilled water supply and return mains. Tracer shall be placed at a distance no less than 6" and no more than 12" above the crown of the pipe.

##### B. Valves

1. All valves shall be long stem, full port ball valves with 2" operating nut.
2. For installation with carbon steel piping system:
  1. Valves shall be furnished completely insulated
  2. Welded ends to connect to piping
3. Rated: 150 psig @ 250°F
4. Approved manufacturers:

1. Vexve or UPM approved equal.
- C. Valve Boxes
1. Valve boxes that allow service/maintenance of the valves should be installed where feasible.
  2. Shall be traffic rated and large enough to provide adequate working room.

**G3050 Cooling Distribution**

## G3051 Chilled Water Supply System

- A. Piping
1. Designer of Record to work with Auburn University Utilities & Energy department for determination of desired piping system for the application.
  2. Cement Lined Ductile Iron Pipe
    1. See [Ductile Iron Chilled Water Supply Piping and Insulation Specifications](#)
  3. High-Density Polyethylene (HDPE)
    1. See [HDPE Chilled Water Supply Piping and Insulation Specifications](#)
    2. Tracer Wire: Continuous #10 solid copper rated for underground service. Connect to all valves and underground steel chilled water supply and return mains. Tracer shall be placed at a distance no less than 6" and no more than 12" above the crown of the pipe.
- B. Bedding & Backfill
1. Trench width to be at least 36" wider than the combined hydronic piping arrangement.
  2. 6" sand bedding below bottom of pipe
  3. Sand backfill to 12" above top of pipe
- C. Valves
1. All valves shall be gate valves.
    1. Non-rising stem valves with 2" square operating nut.
    2. Valve must seal tight (zero leak through).
    3. Pressure Rating: 250-psi AWWA rated working pressure.
    4. M&H or UPM approved equal.
  2. Insulation
    1. Insulation shall be spray ceramic insulation to 100 mils minimum thickness. Product shall be equivalent to CL Systems 100 by Envirotrol, Inc.
    2. Pit wrap to manufacturer's guidelines.
  3. Bolting
    1. Studs: ASTM A 193 / A 193 M, Grade B7, continuously threaded per ASME B 1.1. Class 2A fit, coarse thread series, length per ASME B 16.5.
    2. Nuts: ASTM A 194/A 194 M, Grade 24 or 7, hexagon semi-burnished, heavy series, threaded to ASME B1.1, Class 2B, coarse thread series.
  4. Flange Gaskets
    1. Spiral wound graphite filled in accordance with ASME B16.20, 1/8" thick. Gaskets must be compatible with the flowing fluid, temperature,

and pressure of the system. Product shall be equivalent to Garlock flexseal RW flexible graphite.

D. Valve Boxes

1. Valve boxes that allow service/maintenance of the valves should be installed where feasible.
2. Shall be traffic rated and large enough to provide adequate working room.

**G3060 Fuel Distribution**

A. General

1. Do not install temporary or permanent structures over natural gas mains and laterals.
2. There shall be a minimum separation of 18” between natural gas lines and insulated utility lines.
3. Installation of the gas transmission mains and other gas pipelines shall comply with ASME B31.8.

G3061 Fuel Piping

A. Piping and Fittings

1. See [Piping and Fittings Table](#) for specifications.
2. See [Piping Joints Table](#) for specifications.
3. All pipe and fittings material shall be stabilized against ultraviolet deterioration and suitable for unprotected outdoor storage for at least 4 years.
4. Fittings shall be of the same diameter, type, and wall thickness of the pipeline being constructed.
5. Requirements for natural gas system piping (Heat Fusion Joining) as follows:
  1. Butt, socket, and saddle fusion joints in polyethylene gas pipe shall be made using procedures that have been qualified and approved by the Federal Department of Transportation (DOT) in accordance with CFR, Title 49, Part 192.283.
  2. The Contractor shall ensure that all persons making heat fusion joints have been qualified to make joints in accordance with the above referenced CFR code.
  3. The Contractor shall maintain records of qualified personnel and shall certify that qualified training was received not more than twelve (12) months prior to commencing work.
6. Line tapping fittings shall be bypass type and of such design that flow through the pipeline being tapped will not be interrupted at any time during the tapping operation.
7. Polyethylene gas pipe and fittings may be joined together to other materials by transition fittings or fully restrained mechanical couplings. These devices shall be designed for joining polyethylene gas piping to another material and shall be approved by the Federal Department of Transportation.
8. Transitions between unlike wall thicknesses greater than 1 DR shall be made with a transition nipple or by mechanical means.

B. Valves

1. See [Valve Table](#) for specifications.
  2. All service lines off the main shall have an isolation valve.
  3. All 2" or larger service lines must include a tri-valve arrangement.
  4. All valves installed below grade deeper than 4' shall have a valve extension to terminate within 2' of finished grade.
  5. Valve shall turn left or counterclockwise to open.
- C. Valve Boxes
1. See [Specialty Device Table](#) for specifications.
  2. Valve Boxes shall have a pre-cast concrete collar in landscaped areas and poured-in-place concrete collars in paved areas.
  3. Pre-cast concrete collars shall be 4000 psi with 24" outside diameter with a 10" inside diameter center hole.
  4. Poured-in-place concrete collars shall be 4000 psi 24"x 24" square with inside hole sized to fit valve box.
- D. Pipe Bedding
1. See [Bedding and Backfill Table](#) for specifications.
- E. Meters and Regulators
1. Designer shall include on drawings, in tabular form (i.e. schedule), the service description, minimum design flow (CFH), maximum design flow (CFH), required pressure at inlet and outlet of each meter set (PSIG).
  2. Designer shall provide a layout drawing of the meter set including location of valve(s), regulator(s), and meter(s).
  3. Meter set to be installed by University approved natural gas system contractor.
  4. The Designer shall consult the gas meter manufacturer and include the manufacturer's recommended length of straight pipe runs to be installed, both before and after the meter.
  5. Designer shall notify the University Project Lead a minimum of 60 days before a meter is required to allow for ordering and delivery.
  6. All new services lines are to include installation of a meter and regulator.
  7. Auburn University Utility Services provides all gas meters and meter regulators for services from AU's system.
  8. Locate meters and regulators away from building fresh air intakes.
  9. All above grade black iron or steel gas pipe shall be painted to match meter and regulator with primer, intermediate, and finish coat of 6.5 – 9.5 mils DFT per coat.
- F. Pipe Testing:
1. [Natural Gas Pipe Testing](#)

## **G40 Electrical Site Improvements (Utilities)**

### **G4010 Electrical Distribution**

#### G4013 Underground Power Distribution

##### A. Underground Ducts

1. Duct banks shall be concrete encased PVC for primary and secondary power distribution.
2. Sufficient spare conduits are to be furnished in underground duct banks to allow for installation of one future/additional circuit of the same size/rating as those already provided with cable/conductor.
3. Provide #12 AWG solid copper tracer wire in all non-metallic underground conduits.
4. All permanent electrical service is to be provided underground.

**G4020 Site Lighting**

## G4021 Fixtures and Transformers

## A. Fixtures General

1. Exterior lighting shall meet the lighting power densities as established by ASHRAE 90.1.
2. A dispersed placement pattern of pathway lighting is preferred. Photometric study and catalog cut sheets shall be provided at the Design Development Phase. Document the foot-candle levels at the site boundary.
3. All exterior lighting shall be controlled by a photoelectric cell. A single photocell may be provided for multiple fixtures. Provide a lighting contactor with a HOA switch.
4. Exterior security lighting and exterior building lighting shall not be controlled by the building automation system, unless Parking Lot lighting is being dimmed when unoccupied.
5. Timers are not permitted.
6. No building mounted site lighting shall be used.
7. Power for exterior lighting shall be from multiple circuits fed from the building.
8. Exterior pole lights shall be fed with a minimum of 3 circuits. Install as multi-wired branch circuits and have individual neutral conductors identified with the phase color the entire length of circuit. 10 ga conductor minimum.

## B. Parking Lot and Street Lighting Fixture

1. Approve Manufacturer:
  1. Kim 'Altitude' LED Series or approved equal
2. Color:
  1. 3000 K
3. Housing:
  1. Dark bronze finish.
4. Glass lens

## C. Pedestrian Lighting Fixture

1. Approved Manufacturer:
  1. Holophane 'Granville' LED Series or approved equal
2. Color:
  1. 3000 K

3. Housing:
  1. Dark bronze finish.
4. Glass prismatic lens (acorn fixture).

**G4022 Poles**

- A. Street and Parking Lot
  1. 30' Tapered cast aluminum pole with dark bronze finish on round reinforced concrete pole base extending 30" above grade.
- B. Pedways
  1. 12' Tapered cast aluminum fluted pole with dark bronze finish on round reinforced concrete pole base extending 4" above grade.
  2. Wadsworth base for fluted poles.
  3. Use hinged base with tapered smooth pole in areas with similar light poles.

**G4030 Site Communication and Security****G4031 Site Communication Systems**

- A. Quality Assurance for installing OSP cabling:
  1. Contractor's on-site superintendent must have a minimum of 5 years of OSP experience and must possess one of the following certifications:
    1. Building Industry Consulting Services International (BISCI) Installer 2 for Copper and Optical Fiber
    2. Fiber Optic Association (FOA) CFOS/O certification (Fiber Optic Specialist for Outside Plant Installation)
- B. Duct banks:
  1. Underground conduit installed for telecommunications shall be installed in a concrete encased duct bank located 36" below grade.
  2. Duct banks shall be topped with an orange dye.
  3. When backfilling, provide detectable warning tape printed with "Communication Line Below" 12" above top of duct bank.
  4. All underground conduit (including bored conduit) shall be installed with a copper 12 AWG high density polyethylene (HMWPE) (insulation color orange) tracer wire for locating purposes.
  5. All underground conduit shall be photographed and GPS mapped prior to backfilling.
  6. A minimum of two 4" schedule 40 PVC conduits shall be provided and installed from the appropriate telecommunications manhole/handhole to the building BET telecom room.
  7. Conduits shall have a 210-lb poly pull line installed in each conduit.
  8. 90° bends shall be 48" radius elbows. Standard 90° elbows shall NOT be used.
  9. The UPL and OIT PM shall be notified when the duct bank conduit is installed BEFORE concrete is poured, for inspection and photographing. All duct bank conduits are required to have a mandrel successfully pulled

through each conduit without binding or abnormal pulling tension. A duct bank will not be covered until it has passed inspection by the Owner.

10. Duct banks shall be encased with a minimum 3000 PSI concrete reinforced with rebar cage.
11. Conduit ends shall have compression type plugs installed.
12. Where bends are required, manufactured bends should be used whenever possible. Bends made manually shall be coordinated with OIT and shall not reduce the internal diameter of the conduit. No section of conduit shall contain more than two 90° or equivalent bends between pull points (e.g., handholes, maintenance holes, and vaults). Back to back 90° bends shall be avoided.
13. Manholes shall be a telecommunications-type precast concrete with a precast collar minimum height of 12” with traffic rated frame and cover.
14. The section length of conduit shall not exceed (400 ft) between pulling points.
15. Hand holes shall be Quazite stackable enclosures with traffic-rated lid rated TIER 22.
16. Combined electrical and telecommunication pathways shall be coordinated with the Owner.
17. Typical Communication Duct Banks:
  1. Coordinate requirements and size specific to project needs.

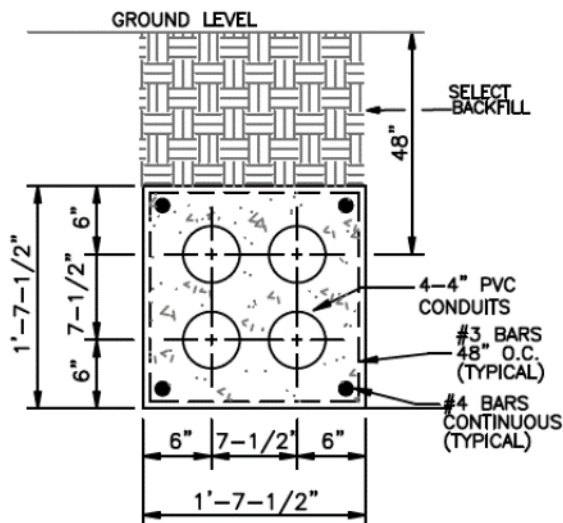

**DUCT SECTION-4 WAY**  
N.T.S. (4 COMMUNICATIONS)

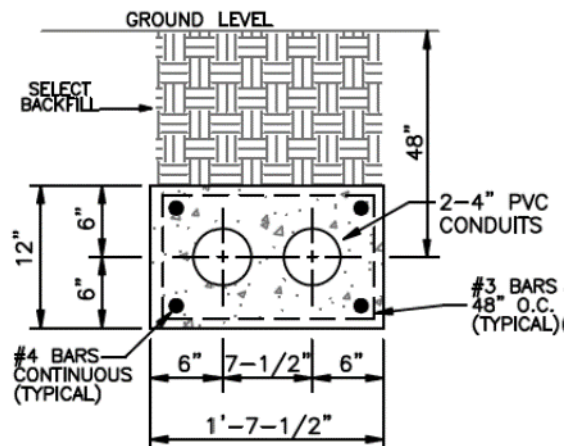

**DUCT SECTION - 2 WAY**  
N.T.S. (2 COMMUNICATIONS)

G4032 Site Security & Alarm Systems

A. Emergency Phones:

1. Specific phone model to be selected IAW OIT’s Preferred Materials List.
  1. <https://auburn.edu/oit/pdfs/telecom/MaterialsListing.pdf>

2. Alternative parts to be pre-approved by OIT.
2. Power for emergency phone shall not be connected to irrigation system power.
3. Power for emergency phone shall be on dedicated circuit, connected to emergency power if generator is provided in project.
4. Shall be ADA compliant.
5. Emergency phones require two conduits from a building depicted on the electrical plans. One 3/4" conduit for power and one 1" conduit for telecom cabling as well as a grounding rod shall be installed. The grounding rod and the conduits shall be installed in the concrete base pad of the emergency phone within the area of the bolt template. The electrical contractor shall install pull strings in both conduits, construct the concrete pad upon which the phone will be mounted, and stub-up the conduits 6-12" above the pad. AU Telecom will supply the electrical contractor with the emergency phone template kit consisting of four j-bolts, nuts, washers, and a plastic spacing template to ensure proper j-bolt spacing in the concrete pad.
6. If a project will impact an emergency phone, that emergency phone shall be relocated temporarily or permanently as required to provide adequate phone coverage on campus.

## Appendix G1 Water Treatment Requirements

### A. [Hydronic System Cleaning/Treatment](#)

## Appendix G2 Standard Utility Details

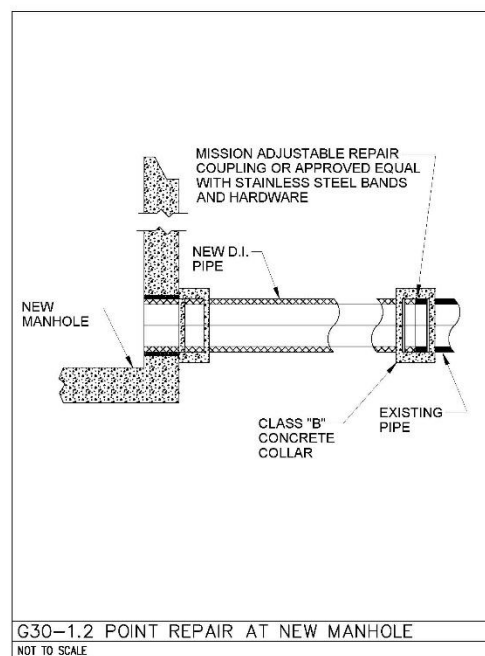
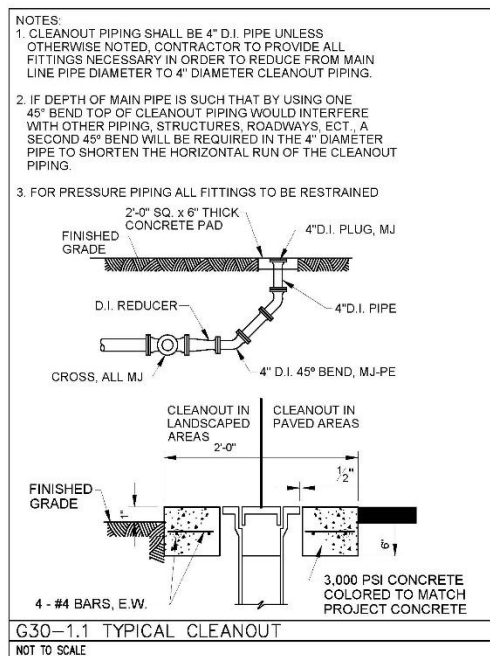

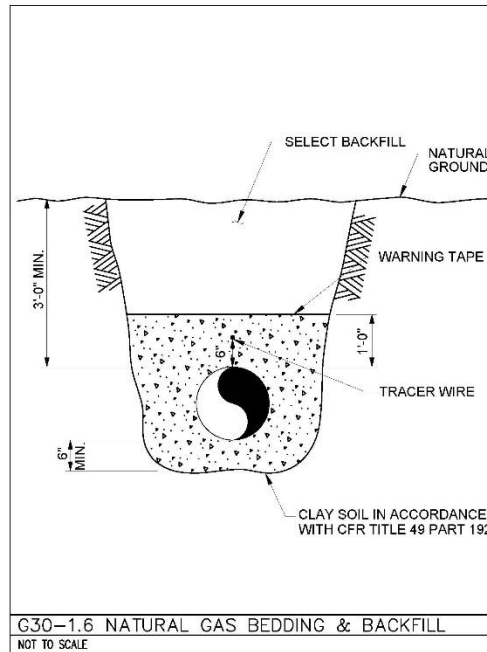
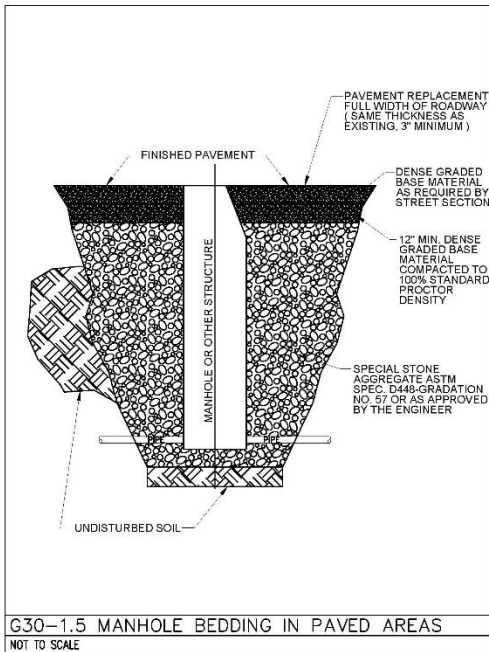
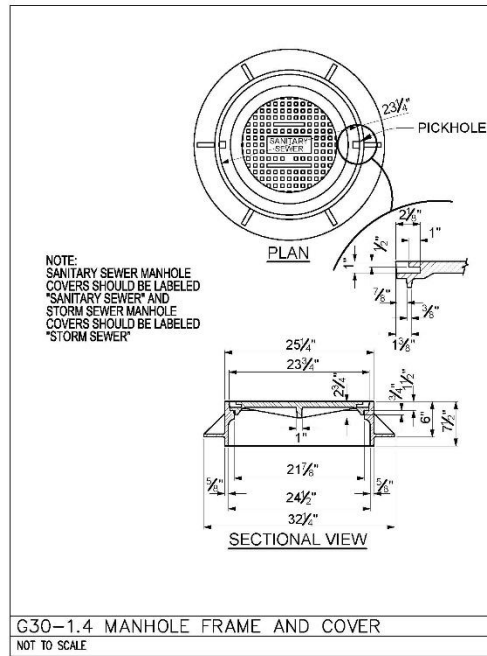
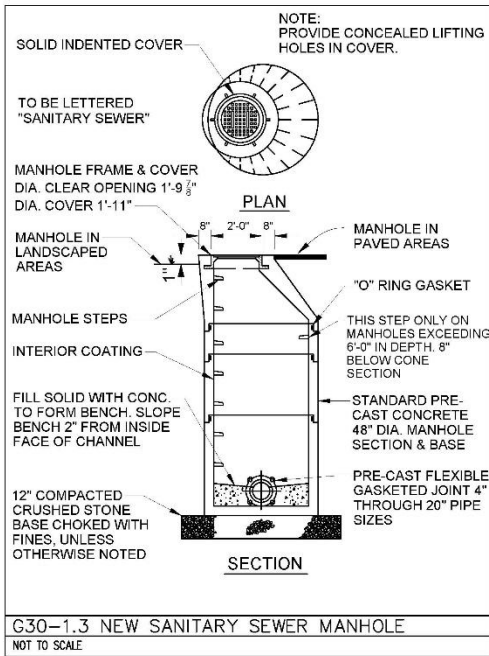

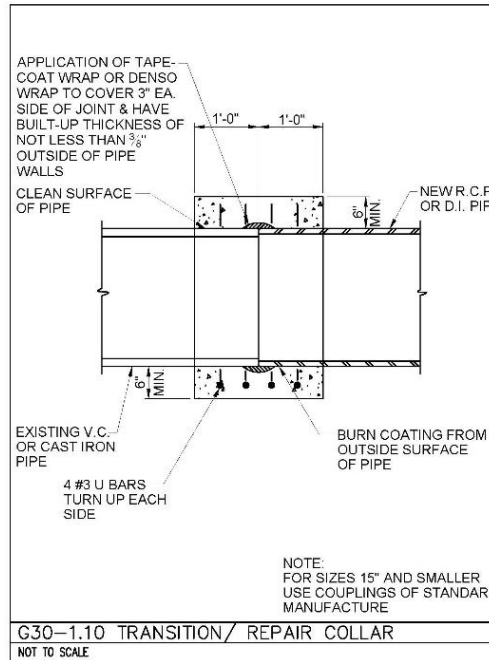
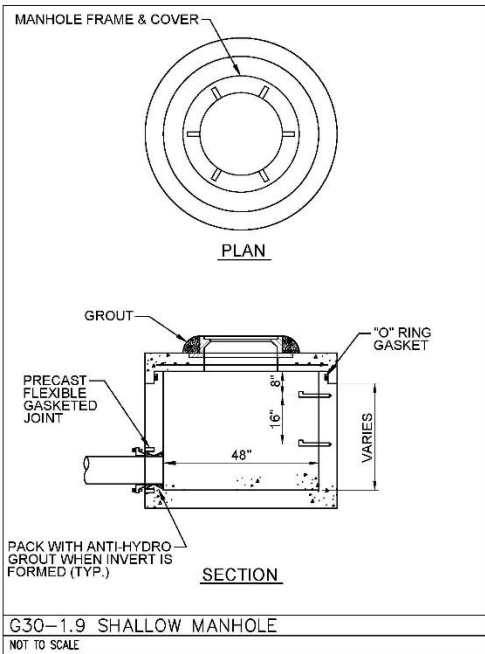
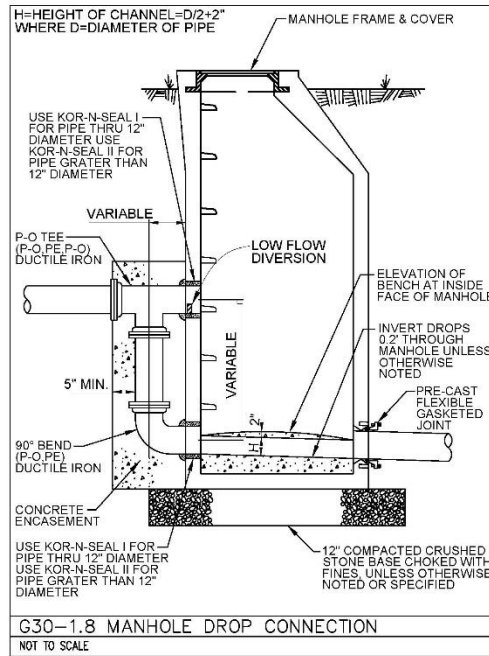
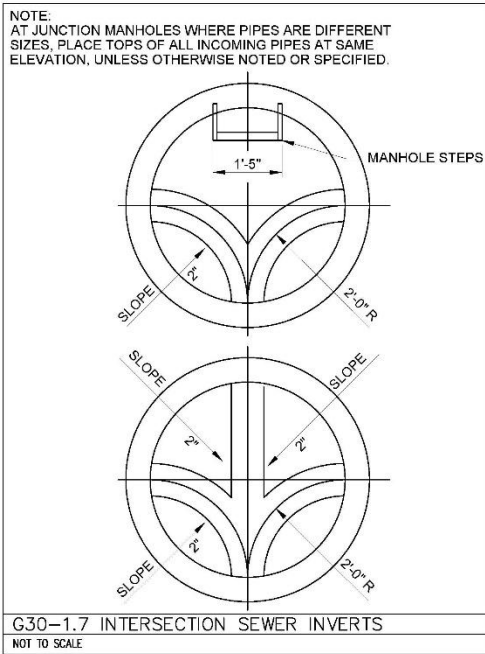

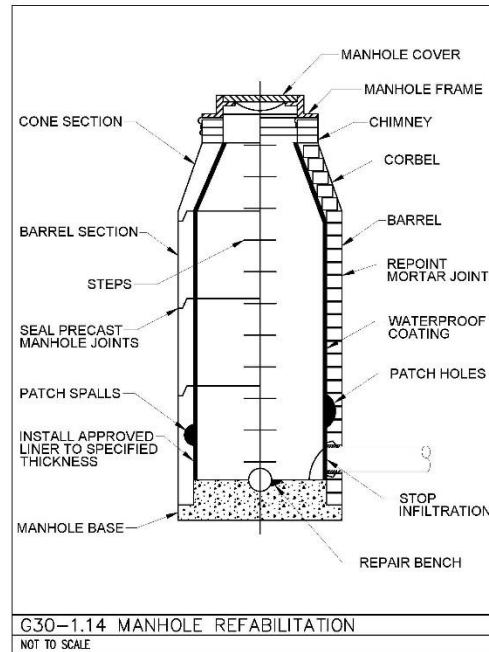
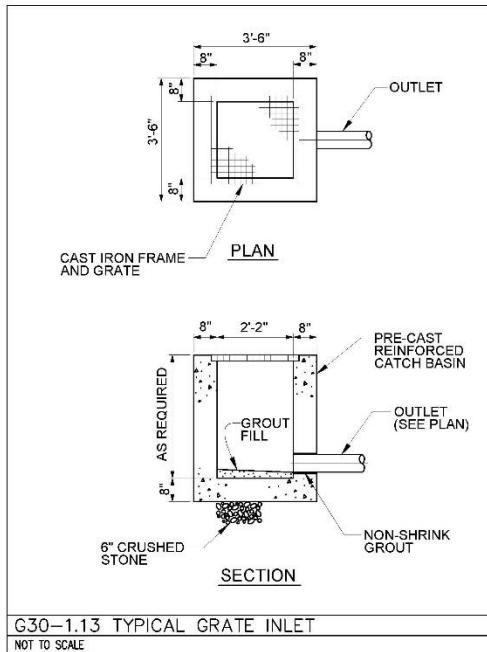
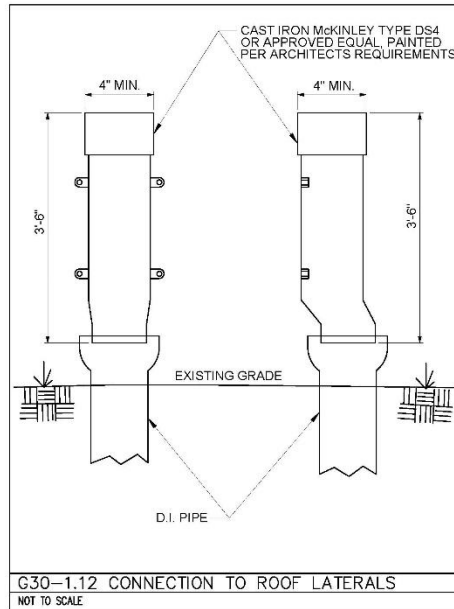
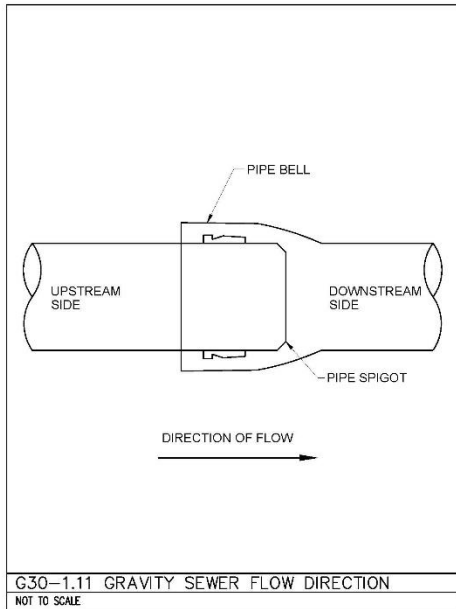

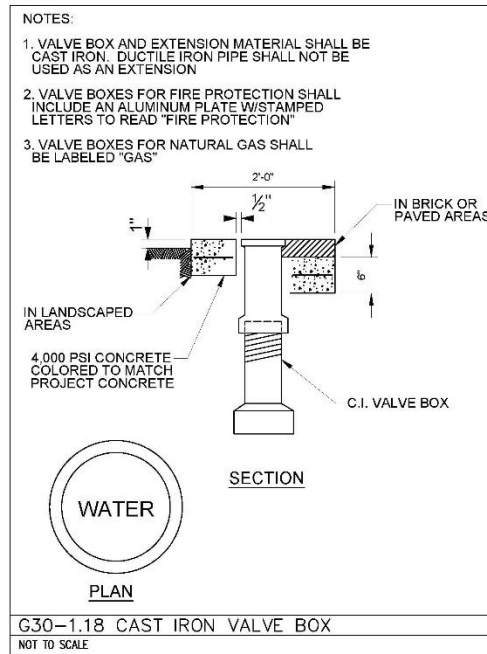
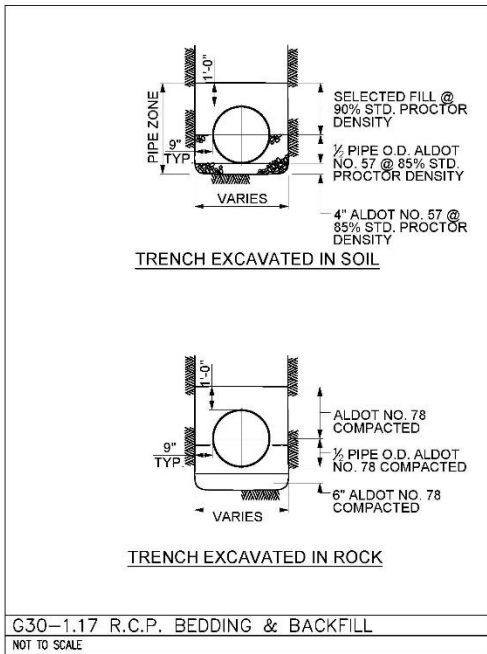
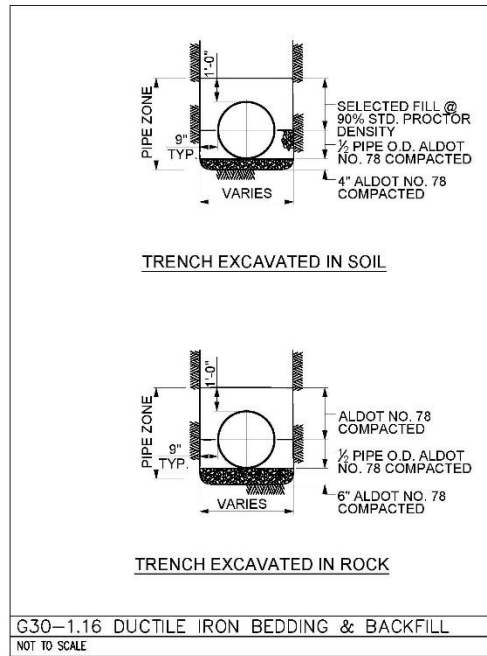
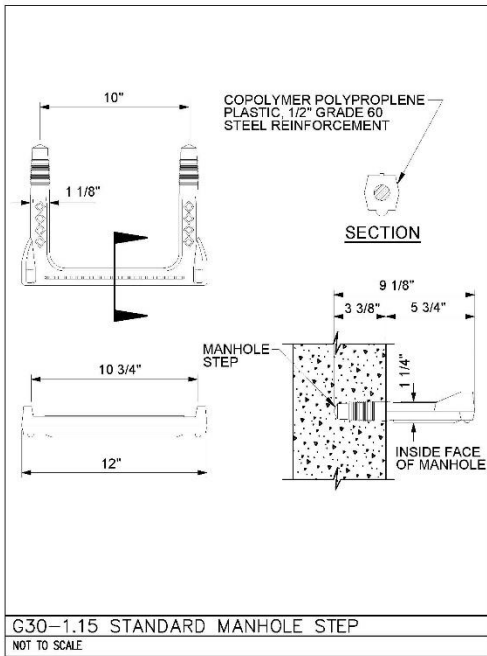

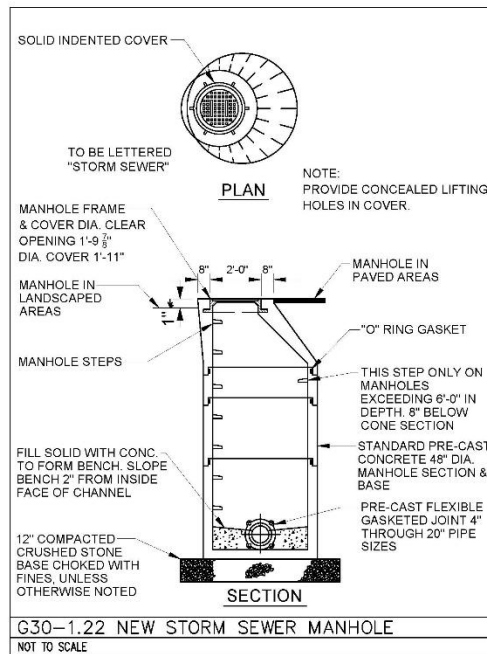
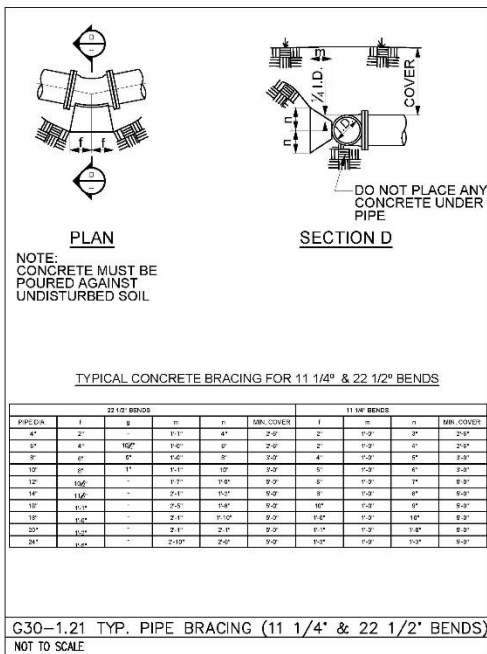
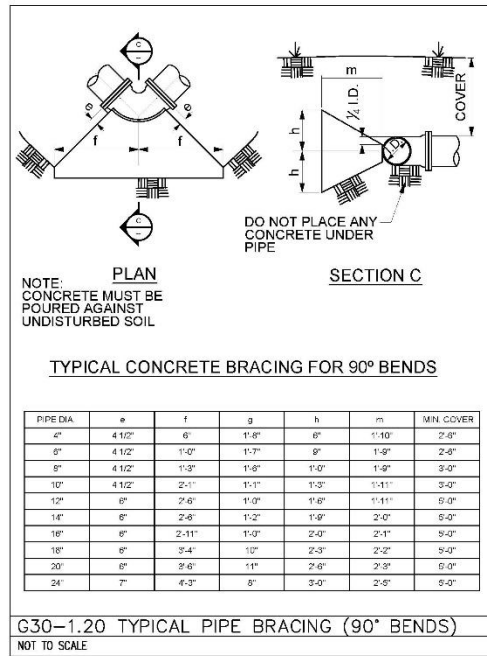
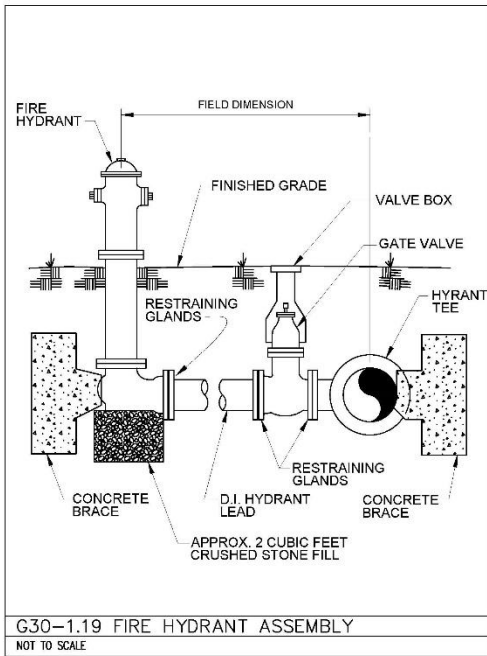





**Document Revision History**

Version	Section	Summary of Change	Date



# 2025 Sustainability & Space Programming Requirements

## INDEX

Sustainability
Space Programming
Document Revision History

## Sustainable Building Standards

Auburn University is committed to sustainable building and construction practices. Designers of Record are expected to provide an environmentally responsible design while adhering to current adopted editions of codes/standards and Auburn University Design and Construction Standards. The standards identify a minimum level of design and process requirements for all new construction and renovation projects while providing enough flexibility for individual project teams to meet project goals.

Using the *Harvard Green Building Standards* project tiers as a model, apply the following table for project-required Elements.

Tier	Area of Concern	Required Elements
1	New building construction and full building renovations.	<ul style="list-style-type: none"> <li>• Sustainability Charette</li> <li>• Life Cycle Cost</li> <li>• Energy Modeling</li> <li>• Commissioning</li> <li>• LEED Silver Compliance</li> </ul>
2	Partial building renovations, building additions, or fit outs. HVAC, Lighting, Plumbing. Finishes in scope. Base building HVAC and envelope are unaffected.	<ul style="list-style-type: none"> <li>• Evaluate energy conservation measures.</li> <li>• Commissioning</li> <li>• LEED Certification not mandatory. Seek LEED requirements were practical.</li> </ul>
3	Systems renovations. Includes AHU replacement, plumbing retrofit, lighting retrofit, elevators, etc.	<ul style="list-style-type: none"> <li>• Evaluate energy conservation measures.</li> <li>• Commission new or existing equipment replacement.</li> <li>• Reduce waste impact by recycle and reuse.</li> <li>• LEED Certification is not required.</li> </ul>
4	Landscape projects, paint, flooring, and roof replacements, etc.	<ul style="list-style-type: none"> <li>• LEED Certification is not required.</li> <li>• Reduce waste impact by recycling and reusing.</li> </ul>

## Space Programming Requirements

The Designers of Record should use these conditions to supplement the building occupant's programming needs. The requirements herein should be incorporated into the building's overall program.

### Attic Space:

- A. Where attic spaces are provided, design the space for future storage space build-out, if not included in the design, to include structural capacity, fire protection, access, and egress.

### “Attic Stock” Storage Room:

- A. A room of the appropriate size (minimum size 8'x10') to store the Attic Stock shall be designed into the project.
- B. The room shall be accessible from a public corridor.

### Custodial Closets:

- A. General
  1. Provide Custodial Closets in each project over 40,000 SF.
  2. Provide one (1) custodial closet for each 15,000 - 18,000 s SF of building floor space with a minimum of one (1) for each floor.
  3. An additional storage room of at least 200 SF in size shall be located in each building.
  4. In each project over 100,000 SF, provide an office and a break room to accommodate eight custodial employees.
- B. Basic Requirements for Custodial Closets:
  1. Dedicated space (i.e., no shared use/function).
  2. Minimum area: 100 SF.
  3. Located adjacent to the freight elevator/service entrance.
  4. Provided with shelving on at least one wall.
  5. Not to be located at the dead end of a corridor, on a stair landing, inside another room, under stairways, or in narrow spaces.
  6. Each Custodial Closet shall be provided with:
    1. Floor drain.
    2. Space for a 6' step ladder.
    3. Pegs for storage of rotary brushes.
    4. Hangers for wet mops over floor receptors.
    5. Hangers for dust mops and brooms furnished by the Owner.
    6. Hard surface walls and 10' high ceilings.
    7. Adjustable shelves for supplies.
    8. A 36" door that swings out of the room.
    9. Minimum 24"x24" terrazzo mop receptor with 4" front curb and 6" side curbs located in one corner on the wall beside the entrance door. The remainder of the floor area in the closet may be trowel finished, sealed

- concrete with a ceramic tile base. A waterproof membrane shall be provided under the entire floor, and the floor shall be pitched to receptor or a drain.
10. Hot and cold water. Faucet shall be threaded for a hose connection, mounted 36" above the floor. Provided with integral check valves and a vacuum breaker before the threaded hose connection.
  11. A duplex receptacle in "open" wall and power for 3 buffers.
  12. Floor space for large floor finishing machine.
  13. Space for 40" H x 26" W x 48" L trash cart.
  14. Adequate lighting, but no light fixtures or sprinkler heads located above mop receptor.
  15. If a fire alarm is present, install a heat detector if a mop sink is provided; provide a smoke detector if no mop sink is provided.

**Single Toilet Room:**

- A. Provide a minimum of one single toilet room within each building core on each floor.
- B. This single restroom is in addition to the code-required plumbing fixtures.
- C. ADA compliant.
- D. Include a baby changing station.
- E. Signage: "RESTROOM" and "BABY CHANGING STATION"

**Shower:**

- A. Provide a minimum of one single-stall shower room within each new or large-scale renovated project which contains office or administrative space.
- B. ADA compliant.
- C. Provide collapsible water retainer shower dam.
- D. Signage: "SHOWER"
- E. May combine with Single Toilet Room.

**Lactation Room:**

- A. Provide a minimum of one lactation room within each new or large-scale renovation project which contains office or administrative space.
- B. Space shall contain:
  1. Sink
  2. Small refrigerator
  3. Counter
  4. Chair
  5. Mirror
- C. Signage: "LACTATION ROOM".

**Mechanical Rooms and Electrical Rooms:**

- A. Provide separate rooms for electrical equipment and mechanical equipment.
- B. No ceilings.

- C. Primary mechanical and electrical equipment rooms shall be located with access to the building exterior and allow for convenient service vehicle access and equipment removal.
- D. These spaces shall not be combined with custodian closets.
- E. Provide fire alarm audio/visual notification and pull station at the exit.
- F. In new facilities, electrical rooms shall be vertically stacked (with sufficient overlap) to permit straight/vertical route of busway and cable raceway between multiple levels.
- G. In new facilities, electrical rooms shall be centrally located (minimal cable lengths) to reduce costs and voltage drop.
- H. Lighting in mechanical/electrical rooms shall operate when normal power is interrupted.
- I. Convenience receptacles in each mechanical/electrical room shall be on dedicated circuits connected to standby generator when one is provided.
- J. Door openings shall swing out of room and shall open to a common corridor or to the exterior of the building and be sized to allow replacement of equipment without structural modifications. Provide panic hardware doors.
- K. Transformer vaults and mechanical equipment rooms should not be accessible to building occupants.
- L. Locate occupants' equipment and controls within space controlled by the occupants. This includes fuses, circuit breakers, switches, valves, etc., that serve departmental equipment.

#### **Telecom & Security/EACS Room Requirements:**

- A. General Room Use & Location
  - 1. Follow the TIA/EIA-569 industry standards for telecommunications spaces and pathways.
  - 2. The telecommunications Building Entrance Terminal (BET) or Main Distribution Frame (MDF) and Intermediate Distribution Frame (IDF) rooms shall:
    - 1. Be dedicated rooms and share no space with mechanical or unrelated electrical equipment.
    - 2. Be accessible from a corridor or the exterior.
    - 3. Have no exterior windows.
  - 3. Minimum of one combined room per floor.
    - 1. Typically, a minimum of one (1) Security/EACS room per floor is required.
  - 4. Additional rooms are required when:
    - 1. Floor area exceeds 10,000 SF.
    - 2. Necessary to maintain cable pathway lengths: <250'.
    - 3. Access Control Equipment requires additional space.

5. Rooms should be sized according to BCSI-TDMM standards. These standards are based on Telecom equipment only. Additional equipment will require more space.
  1. Typical Telecom Room Layout:  
[https://auburn.edu/oit/pdfs/telecom/telecom-room-layout\\_TYPICAL.pdf](https://auburn.edu/oit/pdfs/telecom/telecom-room-layout_TYPICAL.pdf)
- B. Size & Layout
  1. Sized to meet Telecom (BICSI TDMM) and Security equipment needs including future expansion.
  2. Include 3/4" fire-retardant plywood backboards mounted vertically on all walls, painted on all sides. Secure using toggle or butterfly bolts.
  3. Basket/cable tray shall circumnavigate the room mounted at 90–96" AFF.
    1. Provide tray dividers to separate Security wiring from other low voltage wire.
  4. All conduits must terminate directly above/below backboards; no crossing except in corners.
  5. Security conduits must not penetrate more than 3" from the wall with backboards.
  6. No free-hanging cabling—cables must be fully supported.
- C. Environmental Controls (HVAC)
  1. Temperature: 65–73° F
  2. Max Relative Humidity: 55%
  3. Minimum 1 air change per hour.
  4. Dedicated cooling-only HVAC unit, 24/7 operation.
  5. Heat load design: 3,000 Btu/hr minimum. Size to room heat load.
- D. Power & Electrical
  1. Emergency power required for:
    1. All outlets serving Telecom and Security equipment
    2. Lighting circuits
    3. Outlets:
      1. Two 20A 120V NEMA duplex outlets on separate circuits per wall, mounted high (near backboard under cable tray).
      2. One duplex convenience outlet on a dedicated circuit elsewhere in the room.
    4. All outlets must be clearly labeled with electrical panel and circuit.
    5. All equipment power supplies must be on separate circuits for serviceability.
    6. Lighting circuits must not share power with equipment circuits.
    7. Room mounted fan coil unit.
- E. Lighting
  1. Minimum 500 lux (50 foot-candles) at 3' above floor.
  2. Locate lights in the middle of aisles between cabinets and racks.
  3. Switch-controlled near door; no dimmers, timers, or motion sensors.
  4. Emergency lighting: At least one backup fixture.

5. Fixtures mounted minimum 8'-6" AFF.
- F. Construction & Finishes
  1. Minimum ceiling height: 8'-6"
  2. Minimum floor load: 50 lb/sf
  3. Finished walls and sealed concrete or painted floors.
  4. No suspended ceiling.
  5. No floor drains in room.
  6. Only piping directly serving the room may enter. All pipe penetrations must be sealed, no overhead plumbing joints.
  7. Sprinkler heads must have guards.
  8. Doors - 36"W x 80"H minimum. For large equipment access, provide double doors (72"W x 90"H) with no sill and a removable center post or mullion.
  9. Security/EACS reader-equipped lockable door hardware required.
- G. Special Considerations
  1. All electronics are sensitive to EMI and must be isolated from transformers and power panels.
  2. Design coordination with AU OIT Telecom Project Management is required.
  3. AU's Technology Design, Procurement and Installation Responsibility Matrix:
    1. New Buildings or major renovations that include new MDF/IDF spaces will utilize the Contractor for installation of cabling.
      1. [TechnologyMatrix-GC-Sponsored.pdf](#)
    2. All other project types will use AU-OIT Low Voltage Contractor for installation of cabling.
      1. [TechnologyMatrix-OIT-LowVoltageContractor.pdf](#)

### Stairways:

- A. Provide one (1) 20A duplex, 120V receptacle on each floor stair landing.
- B. Natural light in stairwells is desirable.
- C. Lighting shall be wall mounted at the landings at 8'-9' A.F.F.
- D. Provide interior doors on magnetic hold-opens connected to fire alarm system for enclosed stairwells.

### Facility Security

- A. General
  1. This document provides internal policy, guidance, and considerations for integrating physical security in all Auburn University owned, managed, or occupied buildings. Security shall be an integral consideration in the selection and development of both new building sites and renovation projects. The guidelines set forth minimum security features and arrangements that are required for all campus buildings and facilities.

## B. Facility Threat Level (TL) Designation

1. General
  1. The level of security required will be dependent on the function of the facility and of specific space within the facility.
  2. Final determination of the required level(s) of security shall be determined by Auburn University Campus Safety and Security coordinated by the University Project Manager.
2. Designations
  1. TL-1 General
    1. All campus buildings and facilities, not otherwise defined below.
  2. TL-2 Confidential
    1. Buildings, or spaces within buildings or facilities in which information of a confidential nature is stored or otherwise maintained. This category includes but is not limited to human resources file rooms; student records rooms or other areas regulated by the Family Education Rights and Privacy Act; records covered by the Health Insurance Portability and Accountability Act of 1996; and areas housing proprietary research or sensitive operational information.
  3. TL-3 Known Threat
    1. Areas, buildings or other spaces known to be, or logically assumed to be, targeted for destruction, disruption, or vandalism by extremist individuals or groups, as well as areas of specific safety concern to students, faculty, visitors, or staff. These areas include, but are not limited to, the College of Veterinary Medicine; areas housing or providing care for animals; buildings which house controlled substances; student dormitories; parking decks and other certain parking areas and walkways as determined by security specialist from AU Campus Safety & Security
  4. TL-4 Hazardous Materials & Bio-Safety Laboratories
    1. Areas used for storage or utilization of hazardous chemicals or materials and laboratories known to or intended to house potentially dangerous biological or radiological agents.
3. Site Security:
  1. Structural barriers such as bollards and fencing shall be installed at the primary and secondary entrances to new buildings to prevent vehicular approaches and intrusions.
  2. Landscaping shall be selected and placed in such a manner that opportunities for concealment and interference with security camera views are minimized.
  3. TL-1 & TL-2: no additional requirements.
  4. TL-3 & TL-4
    1. Provide locking gates or doors to separate off-limits areas to the public.

C. CCTV Camera Location Requirements

1. TL-1
  1. Coverage of the entire Loading Dock.
  2. Ground level openings.
2. TL-2
  1. Comply with TL-1.
  2. Entrance to confidential information and records storage rooms.
3. TL-3
  1. Comply with TL-2.
  2. Parking lots, parking decks, and roadway entrances
  3. Walkways and stairwells.
4. TL-4
  1. Comply with TL-3.
  2. Entrance to rooms with hazmat and/or biological safety cabinets.
  3. Entrance to rooms with laboratory storage areas.

**Document Revision History**

Version	Section	Summary of Change	Date



# 2025 Door Hardware Standards

## INDEX

Door Hardware Standards
Document Revision History

## LINKED DOCUMENTS

<a href="#">Door Hardware Standards</a>
---

Table of Contents

<b>Introduction</b>		<b>3</b>
<b>Design Basis</b>		3
<b>Definitions</b>		6
<b>Base Operation Intent Quick Reference Guide</b>		7
<b>Manufacturer’s Abbreviations</b>		11
<b>Option List</b>		12
<b><u>Security Hardware Sets</u></b>		
Set: SH-1.00	Electrified Panic Device - With Reader	13
Set: SH-2.00	Electrified Panic Device - No Reader	14
Set: SH-3.00	Monitored Panic Device - Exit Only	15
Set: SH-4.00	Electrified Mortise Lockset: – With Reader	16
Set: SH-5.00	Electrified Mortise Lockset: – No Reader	17
Set: SH-6.00	Monitored Mortise Lockset: – Exit Only	18
Set: SH-7.00	Stairwell Electrified Panic Device – With Reader	19
Set: SH-8.00	Overhead Coiling Door – Monitored	20
<b><u>ADA Hardware Sets</u></b>		
Set: ADA-1.00	ADA Entry in Vestibule - Exterior	21
Set: ADA-2.00	ADA Entry Single Secure Point	22
Set: ADA-3.00	ADA Entry Single Non-Secure Point	23
<b><u>Tornado Shelter Hardware</u></b>		
Set: TS-1.00	Tornado Shelter – Single Door	24
Set: TS-2.00	Tornado Shelter – Double Door	25
<b><u>General Hardware Sets</u></b>		
Set: GH-1.00	Push/Pull Hardware for interior vestibules	26
Set: GH-1.50	Push/Pull Hardware Public Restrooms	26
Set: GH-2.00	Storeroom Function Mortise Lockset Privacy	27
Set: GH-3.00	Function Mortise Lockset	27
Set: GH-4.00	Office Function Mortise Lockset	28
Set: GH-5.00	Passage Function Mortise Lockset Dormitory	28
Set: GH-6.00	Function Mortise Lockset Stairwell Passage	29
Set: GH-7.00	Function Panic Hardware Corridor Smoke/Fire	29
Set: GH-8.00	Panic Hardware Double Corridor Smoke/Fire	30
Set: GH-9.00	Panic Hardware Dormitory Function	31
Set: GH-10.00	Cylindrical Locket	32

**Wiring Schematics and Configurations**

Schematic: SH-01.00	Electrified Panic Device - With Reader	33
Schematic: SH-02.00	Electrified Panic Device - No Reader	34
Schematic: SH-03.00	Monitored Panic Device - Exit Only	35
Schematic: SH-04.00	Electrified Mortise Lockset: – With Reader	36
Schematic: SH-05.00	Electrified Mortise Lockset: – No Reader	37
Schematic: SH-06.00	Monitored Mortise Lockset: – Exit Only	38
Schematic: SH-07.00	Stairwell Electrified Panic Device – With	39
Schematic: SH-08.00	Reader Overhead Coiling Door – Monitored	40
Schematic: ADA-01.11	Standard ADA Access Point - less than 8 ft	41
Schematic: ADA-01.12	Standard ADA Access Point - less than 8 ft	42
Schematic: ADA-01.21	Standard ADA Access Point - greater than 8 ft	43
Schematic: ADA-01.22	Standard ADA Access Point - greater than 8 ft	44
Schematic: ADA-02.11	Single ADA Access Point	45
Schematic: ADA-02.12	Single ADA Access Point	46
Schematic: ADA-03.11	Single ADA Access Point - non-locking	47
Schematic: ADA-03.12	Single ADA Access Point - non-locking	48

<b><u>Preferred Cable and Color Scheme</u></b>	49
--	----

## INTRODUCTION

This is a “living document” and as such is updated on an as needed basis. All Auburn University projects shall adhere to the most current version as related to the bid date, within a reasonable time, of the project documents. The purpose of this document is to provide minimum requirements for the majority of typical openings.

This document applies to all new construction, renovation, and remodeling projects on all Auburn University properties.

If a variance to any item in this document is desired, these shall be reviewed and approved via the Design Standards variance form.

In any instance where this standard and code are not in agreement, code shall dictate the direction.

The Designer shall become familiar with and interpret this section of the Design and Construction Standards in accordance with the programmatic requirements of the Project.

## Design Basis

### A. General

1. Finishes for door hardware shall match either US26D or US32D, consistently throughout the project. On renovation projects, other finishes may be submitted to the University Project Manager for review, if matching the existing finishes is desired.
2. Single-leaf door openings are preferred to double-leaf door openings. If double-leaf door openings are required by the project, a keyed removable mullion shall be provided.
3. If aluminum storefront systems are specified, only wide-stile doors are acceptable. Provide a 12” bottom rail on aluminum storefront doors.
4. Best permanent and construction cores shall be provided by the Contractor. At the completion of the project, AUFM will remove the construction cores, install the permanent cores and return the construction cores to the Contractor. AUFM shall develop the final keying schedule with the end-user, prior to procurement and delivery of the permanent cores. The project lead will arrange a meeting between Access Control and the client to discuss the final keying schedule. This meeting shall be a minimum of 12 weeks prior to the scheduled completion date.
5. Door Hardware Sets schedule shall be provided for all openings shall be included on the construction drawings, immediately adjacent to floor plans. A schedule within the Project Manual is not acceptable.

### B. Access Control Hardware

1. Locksets shall accept Best 7-pin interchangeable cores and cylinders.
2. Manual/key latching or cylinder dogging is not acceptable.
3. All doors and frames shall be prepped for EPT-10 (Electric Power Transfer) when electrified hardware is present.
4. The programming and configuration for the access control system shall be by the Contractor with system integration by the System Integrator to the Access Control Center standards.

5. The use of electric strikes is not permissible due to inherently high failure rates.
  6. The use of electromagnetic locks is not permissible due to safety, security, and the inherently high failure rate.
- C. Hinges
1. Approved Manufacturers:
    1. Hager
    2. McKinney
    3. Stanley
  2. Continuous gear-type hinges, manufactured of extruded 6063-T6 aluminum alloy/temper and consisting of three interlocking extrusions in a pin-less assembly applied to the full height of the door and frame, shall be provided at all exterior openings. Finish to match door.
  3. Butt hinges shall be manufactured to template screw locations and be non-handed.
  4. Thrust bearings shall carry the vertical loads and be completely concealed by the gear cap the full length of the hinge.
  5. Hinges shall comply with ANSI A156, Grade 1.
  6. The use of electric hinges is not permissible due to inherently high failure rates.
- D. Mechanical Locks and Latches
1. Locksets shall accept Best 7-pin interchangeable cores and cylinders.
  2. Plastic parts in locksets are not acceptable.
  3. If specified, mortise-type locksets shall comply with ANSI A156, Grade 1, with 3/4 inch throw latch bolt. Inside trim shall include a turn lever to permit egress when door is locked. Mortise cylinders shall have a concealed internal set screw for securing the cylinder to the body. Best 45H Series shall be provided.
  4. If specified, cylinder-type locksets shall comply with ANSI A156, Grade 1. Inside trim shall include a turn lever to permit egress when door is locked. Provide 2<sup>3</sup>/<sub>4</sub>" backset on cylinder locksets. Best 9K Series shall be provided.
  5. Deadbolts shall be constructed of hardened stainless steel and shall extend a minimum of 1" into the door casing, beyond the door strike. Levers shall be operated with a roller bearing spindle hub mechanism. The use of dead bolts shall be approved by University Project Lead.
  6. Latchbolts shall extend a minimum of 3/8" into the door casing, beyond the door strike.
  7. Furnish locksets with sufficient curved strike lip to protect door trim.
  8. Locksets to have self-aligning, thru-bolted trim.
  9. Auxiliary dead latches shall be constructed of one piece hardened stainless steel, permanently lubricated.
  10. Lever handles shall be forged of cast brass, bronze, or stainless steel and shall conform to ANSI A117.1. Hollow cavity levers are not acceptable.
  11. Mechanical dogging is not allowed.
- E. Door Closers
1. Closers shall be provided by LCN.

2. Closers on exterior openings shall be LCN 4040 Series.
  3. Closers on interior openings shall be LCN 1461 Series.
  4. Closers shall be mounted on interior side of space/room. Closer shall be mounted in an inverted overhead position or in a parallel arm position.
  5. Closers shall be equipped with “delayed-action” feature.
  6. Closers shall be equipped with “back-check” feature.
  7. Closers shall have a ten-year warranty.
  8. Hold open alarms are not allowed.
- F. Operating Trim
1. Approved Manufacturers:
    1. Glynn-Johnson
    2. McKinney
    3. Rockwood
  2. Flush and surface bolts shall comply with ANSI A156, Grade 1.
  3. Coordinators shall comply with ANSI A156, Grade 1.
  4. Where through-bolts are used to attach hardware to doors, spacer sleeves in doors shall be provided to prevent collapse of the door.
  5. Thru-bolt fasteners shall be templated so as not to make contact with the frame assembly.
- G. Architectural Trim
1. Approved Manufacturers:
    1. Glynn-Johnson
    2. McKinney
    3. Rockwood
  2. Metal protection plates shall comply with ANSI A156, Grade 1. Provide .050 stainless steel plate with four beveled edges, door leaf width, less 2” for a single door, less 1” for pairs of doors. Provide 8” height kick- and 34” for armor-plate.
  3. Furnish screws to match finish.
- H. Door Stops and Holders
1. Approved Manufacturers:
    1. Glynn-Johnson
    2. Rockwood
    3. Sargent
  2. Provide an overhead stop at exterior openings, similar to Glynn-Johnson 100.
  3. Wall stops are preferred.
  4. Floor stops are not desired unless a wall stop cannot be provided.
  5. Electromagnetic hold opens, tied into the fire alarm system, may be used on interior smoke and fire doors located in corridors.
- I. Door Seals
1. Approved Manufacturers:
    1. National Guard
    2. Pemko
    3. Zero
  2. Provide sound-rated seals at all classrooms, offices and sleeping units, and those spaces recommended by the Designer, or Acoustician.

3. Weatherstripping shall be provided by the storefront manufacturer.
- J. Thresholds
  1. Approved Manufacturers:
    1. National Guard
    2. Pemko
    3. Zero
  2. Provide ADA-compliant thresholds at all exterior openings and those spaces recommended by the Designer.

**DEFINITIONS**

SH: Security Hardware. Monitored by electronic access control system

GH: General Hardware. No electronic monitoring.

ADA: Openings requiring some level of compliance with the Americans with Disabilities Act (ADA) regulations.

TS: Tornado Shelter.

**Base Operation Intent Quick Reference Guide**

AREA TYPE	OPENING TYPE	BASE OPERATION INTENT	HW SET <sup>(1)</sup>
<ul style="list-style-type: none"> <li>Exterior Opening ADA accessible with Vestibule</li> </ul>	Main Entry Point	<ul style="list-style-type: none"> <li>Access controlled by credential access and electronically.</li> <li>Capable of real-time remote programming and monitoring.</li> <li>Free egress at all times.</li> </ul>	ADA-01.00
<ul style="list-style-type: none"> <li>Exterior Opening</li> </ul>	Main Entry Point	<ul style="list-style-type: none"> <li>Access controlled by credential access and electronically.</li> <li>Capable of real-time remote programming and monitoring.</li> <li>Free egress at all times.</li> </ul>	SH-01.00
<ul style="list-style-type: none"> <li>Exterior Opening</li> </ul>	Secondary Entry Point	<ul style="list-style-type: none"> <li>Access controlled electronically.</li> <li>Capable of real-time remote programming and monitoring.</li> <li>Free egress at all times.</li> </ul>	SH-02.00
<ul style="list-style-type: none"> <li>Exterior Opening</li> </ul>	Exit Only Point	<ul style="list-style-type: none"> <li>Access is never available.</li> <li>Capable of real-time remote monitoring.</li> <li>Free egress at all times.</li> </ul>	SH-03.00
<ul style="list-style-type: none"> <li>Interior vestibule ADA accessible</li> </ul>	Secondary Entry Point	<ul style="list-style-type: none"> <li>ADA operated opening</li> <li>Free ingress and egress at all times.</li> <li>Non-locking opening</li> </ul>	ADA-03.00
<ul style="list-style-type: none"> <li>Interior vestibule</li> </ul>	Secondary Entry Point	<ul style="list-style-type: none"> <li>Free ingress and egress at all times.</li> </ul>	GH-1.00
<ul style="list-style-type: none"> <li>Classroom <sup>(2)</sup></li> <li>Research Lab <sup>(2)</sup></li> <li>Computer Lab <sup>(2)</sup></li> <li>Assembly Hall <sup>(2)</sup></li> </ul>	Main Entry Point for this room type with occupancy of less than 50 persons.	<ul style="list-style-type: none"> <li>Access controlled by credential access and electronically.</li> <li>Capable of real-time remote programming and monitoring.</li> <li>Free egress at all times.</li> </ul>	SH-01.00 SH-04.00
<ul style="list-style-type: none"> <li>Classroom ADA</li> <li>Research Lab ADA</li> <li>Computer Lab ADA</li> <li>Assembly Hall ADA</li> </ul>	Main Entry Point for this room type with occupancy of 50 persons or more.	<ul style="list-style-type: none"> <li>Access controlled by credential access and electronically.</li> <li>Capable of real-time remote programming and monitoring.</li> <li>Free egress at all times.</li> </ul>	ADA-02.00

<ul style="list-style-type: none"> <li>• Classroom</li> <li>• Research Lab</li> <li>• Computer Lab</li> <li>• Assembly Hall</li> </ul>	Secondary Entry Point for this room type regardless of occupancy count.	<ul style="list-style-type: none"> <li>• Access controlled electronically.</li> <li>• Capable of real-time remote programming and monitoring.</li> <li>• Free egress at all times.</li> </ul>	SH-02.00 SH-05.00
<ul style="list-style-type: none"> <li>• Classroom</li> <li>• Research Lab</li> <li>• Computer Lab</li> <li>• Assembly Hall</li> </ul>	Exit Only Point for this room type regardless of occupancy.	<ul style="list-style-type: none"> <li>• Access is never available.</li> <li>• Capable of real-time remote monitoring.</li> <li>• Free egress at all times.</li> </ul>	SH-03.00 SH-06.00
<ul style="list-style-type: none"> <li>• Mechanical Room</li> <li>• Electrical Room</li> <li>• Fire Pump Room</li> <li>• Telecomm Room</li> <li>• Elevator Room</li> <li>• Security/Access Control Room</li> </ul>	Main Entry Point	<ul style="list-style-type: none"> <li>• Access controlled by credential access and electronically.</li> <li>• Capable of real-time remote programming and monitoring.</li> <li>• Free egress at all times.</li> </ul>	SH-1.00
<ul style="list-style-type: none"> <li>• Mechanical Room</li> <li>• Electrical Room</li> <li>• Fire Pump Room</li> <li>• Telecomm Room</li> <li>• Elevator Room</li> <li>• Security/Access Control Room</li> </ul>	Secondary Entry Point	<ul style="list-style-type: none"> <li>• Access controlled electronically.</li> <li>• Capable of real-time remote programming and monitoring.</li> <li>• Free egress at all times.</li> </ul>	SH-02.00
<ul style="list-style-type: none"> <li>• Mechanical Room</li> <li>• Electrical Room</li> <li>• Fire Pump Room</li> <li>• Telecomm Room</li> <li>• Elevator Room</li> <li>• Security/Access Control Room</li> </ul>	Exit Only Point	<ul style="list-style-type: none"> <li>• Access is never available.</li> <li>• Capable of real-time remote monitoring.</li> <li>• Free egress at all times.</li> </ul>	SH-03.00
<ul style="list-style-type: none"> <li>• Custodial Room</li> <li>• Storage Room</li> </ul>	Main entry point	<ul style="list-style-type: none"> <li>• Door is never unlocked</li> <li>• Access by key from outside</li> <li>• Free egress at all times</li> </ul>	GH-02.00
<ul style="list-style-type: none"> <li>• Restroom – Public</li> </ul>	Main entry point	<ul style="list-style-type: none"> <li>• Door is never locked</li> <li>• Free egress at all times</li> </ul>	GH-01.50
<ul style="list-style-type: none"> <li>• Restroom – Private</li> <li>• Mother’s Room</li> </ul>	Main entry point	<ul style="list-style-type: none"> <li>• Lockable from inside only</li> <li>• Visual indication of occupancy</li> <li>• Free egress at all times</li> </ul>	GH-03.00
<ul style="list-style-type: none"> <li>• Office</li> </ul>	Main entry point	<ul style="list-style-type: none"> <li>• Access by key from outside</li> <li>• May be locked from either side</li> <li>• Maybe unlocked from either side</li> <li>• Free egress at all times</li> </ul>	GH-04.00

• Office Suite Entry	Main entry point	<ul style="list-style-type: none"> <li>Access controlled by credential access and electronically.</li> <li>Capable of real-time remote programming and monitoring.</li> <li>Free egress at all times.</li> </ul>	SH-01.00 SH-04.00
• Office Suite Entry	Secondary entry point	<ul style="list-style-type: none"> <li>Access controlled by credential access and electronically.</li> <li>Capable of real-time remote programming and monitoring.</li> <li>Free egress at all times.</li> </ul>	SH-01.00 SH-02.00 SH-04.00 SH-05.00
• Office Suite Entry	Exit only point	<ul style="list-style-type: none"> <li>Access is never available.</li> <li>Capable of real-time remote monitoring.</li> <li>Free egress at all times.</li> </ul>	SH-03.00 SH-06.00
• Terrace/Balcony with access to exterior.	Main entry point Egress is free into the building.	<ul style="list-style-type: none"> <li>Access controlled by credential access and electronically.</li> <li>Capable of real-time remote programming and monitoring.</li> <li>Free egress at all times.</li> </ul>	SH-01.00 SH-04.00
• Closet: - Secure	Secure access point	<ul style="list-style-type: none"> <li>Access by key from outside</li> <li>Free egress at all times</li> </ul>	GH-02.00
• Closet: – Non Secure	Non-secure access point	<ul style="list-style-type: none"> <li>Door is never locked</li> <li>Free egress at all times</li> </ul>	GH-05.00
• Dorm – Suite	Main entry point	<ul style="list-style-type: none"> <li>Access by key from outside</li> <li>Door is never unlocked</li> <li>Free egress at all times</li> </ul>	GH-06.00
• Dorm – Bedroom	Main entry point	<ul style="list-style-type: none"> <li>Access by key from outside</li> <li>Free egress at all times</li> </ul>	GH-10.00
• Corridor – Security Point	Secure access point	<ul style="list-style-type: none"> <li>Access controlled by credential access and electronically.</li> <li>Capable of real-time remote programming and monitoring.</li> <li>Free egress at all times.</li> </ul>	SH-01.00
• Corridor – Smoke/Fire	Smoke/Fire containment	<ul style="list-style-type: none"> <li>Door cannot be locked</li> <li>Electrically held open when not in use and is connected to Fire Alarm system to close during a smoke/fire event</li> <li>Doors must positive latch</li> <li>Free egress at all times</li> </ul>	GH-08.00
• Stairwell - General	Non-secure access point	<ul style="list-style-type: none"> <li>Door cannot be locked</li> </ul>	GH-07.00

		<ul style="list-style-type: none"> <li>• Doors must positive latch at all times</li> <li>• Free egress at all times</li> </ul>	
<ul style="list-style-type: none"> <li>• Stairwell – Secure Access Point</li> </ul>	Secure access point	<ul style="list-style-type: none"> <li>• Access controlled by credential access and electronically.</li> <li>• Capable of real-time remote programming and monitoring.</li> <li>• Doors must positive latch at all times</li> <li>• Free egress at all times.</li> <li>• During an active fire event door will unlock.</li> </ul>	SH-07.00
<ul style="list-style-type: none"> <li>• Tornado Shelter</li> </ul>	Reinforced Door System	<ul style="list-style-type: none"> <li>• Door cannot be locked</li> <li>• Electrically held open when not in use</li> <li>• Can be released to close electronically during a sheltering event</li> <li>• Doors must positive latch</li> <li>• Free ingress and egress at all times</li> </ul>	TS-01.00 TS-02.00
<ul style="list-style-type: none"> <li>• Coiling Overhead Roll-Up Door - Exterior</li> </ul>	Exterior Roll-Up Door	<ul style="list-style-type: none"> <li>• Capable of real-time remote monitoring</li> </ul>	SH-08.00

- (1) Some areas may offer multiple hardware sets dependent on life safety code requirements or client preferences for usage and level of desired security.
- (2) A panic hardware device shall be used in any situation that code requires, regardless of the standard hardware set listed general applications. Fire and Life Safety Requirement shall determine if panic hardware must be used.
- (3) Double door openings are to be avoided where possible. However, when used must contain a keyed removable mullion

**Manufacturer's Abbreviations**

<b><u>Code</u></b>	<b><u>Name</u></b>
ALG	ALLEGION
ALT	ALTRONIX
APT	APTIQ
BES	BEST ACCESS SYSTEM
CUR	CURRAN ENGINEERING
DOR	DORMAKABA
GE	GENERAL ELECTRIC
GLY	GLYNN JOHNSON
HAG	HAGER HINGE
IVE	IVES
LCN	LCN
LNL	LENEL
MCK	MCKINNY
NGP	NATIONAL GUARD PRODUCTS
PEM	PEMKO
ROC	ROCKWOOD
SCE	SCHLAGE ELECTRONICS
SEC	SECURITRON
SEN	SENTROL
STA	STANLEY
TRI	TRIMCO
VON	VON DUPRIN
WIK	WIKK INDUSTRIES

**Option List**

<b><u>Code</u></b>	<b><u>Description</u></b>
C	QUICK CONNECT WIRING SYSTEM
EL	ELECTRIC UNLOCKING - 98 RIM ("E" TRIMS)
RX	REQUEST TO EXIT
24V	24V SOLENOID (STD)
CON	MOLEX ELECTRICAL CONNECTOR
CON	MOLEX ELECTRICAL CONNECTOR (EPT 10)
DEL	DELAYED ACTION
FSE	FAIL SECURE-EL. UNLOCKING ("E" TRIMS)
NRP	NON REMOVEABLE PIN STD/HWT HINGE
QEL	QUIET ELECTRIC LATCH RETRACTION
RQE	REQUEST TO EXIT
VIN	VISUAL INDICATOR
VIT	VISUAL INDICTOR THUMB-TURN
24VDC	24-Volt Direct Current (for "E" trims)
WP-RX	WATERPROOF REQUEST TO EXIT
EPT Prep	Electrical Power Transfer (EPT) Prep (full mortise)
900-4RL-FA	4 Relay Board Output Integrated Logic with Fire Alarm Relay

**SET: SH-01.00**

Opening Type: Electrified Panic Device – with Reader

Opening with Reader and panic-device hardware. Used as an ingress and egress point during both normal operational hours and afterhours access. Free egress at all times.

QTY	TYPE	DESCRIPTION	FINISH	MFGR
1	READER <sup>(4)</sup>	Mobile Enabled Multi-Technology Reader	BLK <sup>(2)</sup>	SCE
1	1076 <sup>(1)</sup>	Door Contact	TBD <sup>(2)</sup>	SEN
1	Trove3m3	Trove 3 Power Supply for Lenel Panels	N/A	ALT
1	98/99 QELWP-RX CON <sup>(1)</sup>	Electrified Exit Rim Device w/ Quick Connects	TBD <sup>(2)</sup>	VON
1	PULL TRIM <sup>(1)</sup>	Pull Trim	TBD <sup>(2)</sup>	TBD
1	EPT-10-CON <sup>(1)</sup>	Power Transfer w/ Quick Connects	TBD <sup>(2)</sup>	ALG
1	112HDxEPT <sup>(1)</sup>	Continuous Hinge w/ EPT Prep	TBD <sup>(2)</sup>	IVE
1	12E72S2RP	Rim Cylinder	TBD <sup>(2)</sup>	BES
1	4040XP <sup>(1)</sup>	Door Closer	TBD <sup>(2)</sup>	LCN
1	CON-38 <sup>(1)</sup> <sup>(3)</sup>	38” Quick Connect Device to EPT Harness	N/A	ALG
1	CON-192P <sup>(1)</sup> <sup>(3)</sup>	192” Quick Connect EPT to JB Harness	N/A	ALG

- <sup>(1)</sup> Exact part number TBD upon door survey
- <sup>(2)</sup> Finish TBD upon door survey. Preferred finishes are Satin Chrome or Dark Bronze.
- <sup>(3)</sup> Wiring harnesses are used to connect the door hardware (exit device) to the EPT and from the EPT to the junction box. Consult door manufacturer for harness length requirements.
- <sup>(4)</sup> Schlage MTB11 for Mullion Mount, MTB15 for Wall Mount set to Auburn University Configuration.

Notes:

- Opening shall receive all components necessary in order to electronically lock and unlock the door and to allow entry with a valid Auburn University credential.
- Door Hardware shall allow free egress at all times.
- The status of the door shall be monitored via the existing access control software. The condition of the door shall be programmable within the software to lock and/or unlock according to the predefined time-zones within the software.
- Upon a forced door and/or door held condition the software shall initiate an alarm to alert the Auburn University Department of Campus Safety & Security of the condition of the door.
- The door must be capable of real-time remote programming and monitoring.

**SET: SH-02.00**

Opening Type: Electrified Panic Device – no Reader

Opening with panic-device hardware and without Reader used for both ingress and egress during normal operating hours. Free egress at all times.

QTY	TYPE	DESCRIPTION	FINISH	MFGR
1	1076 <sup>(1)</sup>	Door Contact	TBD <sup>(2)</sup>	SEN
1	Trove3m3	Trove 3 Power Supply for Lenel Panels	N/A	ALT
1	98/99 QEL WP-RX CON <sup>(1)</sup>	Electrified Exit Rim Device w/ Quick Connects	TBD <sup>(2)</sup>	VON
1	PULL TRIM <sup>(1)</sup>	Pull Trim	TBD <sup>(2)</sup>	TBD
1	EPT-10-CON <sup>(1)</sup>	Power Transfer w/ Quick Connects	TBD <sup>(2)</sup>	ALG
1	112HDxEPT <sup>(1)</sup>	Continuous Hinge w/ EPT Prep	TBD <sup>(2)</sup>	IVE
1	4040XP <sup>(1)</sup>	Door Closer	TBD <sup>(2)</sup>	LCN
1	CON-38 <sup>(1)</sup> <sup>(4)</sup>	38” Quick Connect Device to EPT Harness	N/A	ALG
1	CON-192P <sup>(1)</sup> <sup>(4)</sup>	192” Quick Connect EPT to JB Harness	N/A	ALG

- <sup>(1)</sup> Exact part number TBD upon door survey
- <sup>(2)</sup> Finish TBD upon door survey. Preferred finishes are Satin Chrome or Dark Bronze
- <sup>(3)</sup> Wiring harnesses are used to connect the door hardware (exit device) to the EPT and from the EPT to the junction box. Consult door manufacturer for harness length requirements.
- <sup>(4)</sup> Quantity TBD upon door survey

Notes:

- Opening shall receive all components necessary in order to electronically lock and unlock the door.
- The status of the door shall be monitored via the existing access control software.
- The condition of the door shall be programmable within the software to lock and/or unlock according to the predefined time-zones within the software.
- Upon a forced door and/or door held condition the software shall initiate an alarm to alert the Auburn University Department of Campus Safety & Security of the condition of the door.
- The door must be capable of real-time remote programming and monitoring.

**SET: SH-03.00**

Opening Type: Monitored Panic Device – Exit Only

Opening with panic-device hardware, no exterior trim, used for egress only. Free egress at all times.

QTY	TYPE	DESCRIPTION	FINISH	MFR
1	1076 <sup>(1)</sup>	Door Contact	TBD (2)	SEN
1	98/99EO WP-RX CON <sup>(1)</sup>	Rim Device w/ Quick Connects	TBD (2)	VON
1	EPT-10-CON <sup>(1)</sup>	Power Transfer w/ Quick Connects	TBD (2)	ALG
1	112HDxEPT <sup>(1)</sup>	Continuous Hinge w/ EPT Prep	TBD (2)	IVE
1	4040XP <sup>(1)</sup>	Door Closer	TBD (2)	LCN
1	CON-38 <sup>(1)(3)</sup>	38" Quick Connect Device to EPT Harness	N/A	ALG
1	CON-192P <sup>(1)(3)</sup>	192" Quick Connect EPT to JB Harness	N/A	ALG

- (1) Exact part number TBD upon door survey
- (2) Finish TBD upon door survey. Preferred finishes are Satin Chrome or Dark Bronze
- (3) Wiring harnesses are used to connect the door hardware (exit device) to the EPT and from the EPT to the junction box. Consult door manufacturer for harness length requirements.
- (4) Quantity TBD upon door survey

Notes:

- Opening shall receive all components necessary in order for the status of the door to be monitored via the existing access control software.
- Upon a forced door and/or door held condition the software shall initiate an alarm to alert the Auburn University Department of Campus Safety & Security of the condition of the door.
- The door must be capable of real-time remote monitoring.

**SET: SH-04.00**

Opening Type: Electrified Mortise Lockset – With Reader

Opening with Reader and Mortise Lockset hardware. Used as an ingress and egress point during normal operational hours and controlled afterhours access. Free egress at all times.

QTY	TYPE	DESCRIPTION	FINISH	MFGR
1	READER <sup>(4)</sup>	Mobile Enabled Multi-Technology Reader	BLK (2)	SCE
1	45HW7DEU15H	Electrified Lockset: w/ DS, RQE & Quick Connects	TBD (2)	BES
1	626RH DS RQE C 24V <sup>(1)</sup>			
1	EPT-12C <sup>(1)</sup>	Power Transfer w/ Quick Connects	TBD (2)	STA
1	4040XP <sup>(1)</sup>	Door Closer	TBD (2)	LCN
1	WH-38 <sup>(1)(3)</sup>	38” Quick Connect Lock to EPT Harness	N/A	STA
1	WH-192P <sup>(1)(3)</sup>	192” Quick Connect EPT to JB Harness	N/A	STA
1	Trove3m3	Trove 3 Power Supply for Lenel Panels	N/A	ALT

- (1) Exact part number TBD upon door survey
- (2) Finish TBD upon door survey. Preferred finishes are Satin Chrome or Dark Bronze
- (3) Wiring harnesses are used to connect the door hardware (mortise lockset) to the EPT and from the EPT to the junction box. Consult door manufacturer for harness length requirements.
- (4) Schlage MTB11 for Mullion Mount, MTB15 for Wall Mount set to Auburn University Configuration.
- (5) Exact part number and amperage required TBD by system requirements.
- (6) Quantity TBD upon door survey

Notes:

- Opening shall receive all components necessary to electronically lock and unlock the door and to allow entry with a valid Auburn University credential.
- Door Hardware shall always allow free egress.
- The status of the door shall be monitored via the existing access control software.
- The condition of the door shall be programmable within the software to lock and/or unlock according to the predefined time-zones within the software.
- Upon a forced door and/or door held condition the software shall initiate an alarm to alert the Auburn University Department of Campus Safety & Security of the condition of the door.
- The door must be capable of real-time remote programming and monitoring.

**SET: SH-05.00**

Opening Type: Electrified Mortise Lockset – No Reader

Opening with Mortise Lockset hardware without reader. Used for both ingress and egress during normal operating hours and no afterhours access. Free egress at all times.

QTY	TYPE	DESCRIPTION	FINISH	MFGR
1	45HW7DEU15H 626RH DS RQE C 24V <sup>(1)</sup>	Electrified Lockset: w/ DS, RQE & Quick Connects	TBD <sup>(2)</sup>	BES
1	EPT-12C <sup>(1)</sup>	Power Transfer w/ Quick Connects	TBD <sup>(2)</sup>	STA
3	3CB1HWx4.5x4.5 <sup>(1)</sup>	Butt Hinges	26D <sup>(2)</sup>	IVE
1	4040XP <sup>(1)</sup>	Door Closer	TBD <sup>(2)</sup>	LCN
1	WH-38 <sup>(1)(3)</sup>	38” Quick Connect Lock to EPT Harness	N/A	STA
1	WH-192P <sup>(1)(3)</sup>	192” Quick Connect EPT to JB Harness	N/A	STA
1	Trove3m3	Trove 3 Power Supply for Lenel Panels	N/A	ALT

- <sup>(1)</sup> Exact part number TBD upon door survey
- <sup>(2)</sup> Finish TBD upon door survey. Preferred finishes are Satin Chrome or Dark Bronze.
- <sup>(3)</sup> Wiring harnesses are used to connect the door hardware (mortise lockset) to the EPT and from the EPT to the junction box. Consult door manufacturer for harness length requirements.
- <sup>(4)</sup> Exact part number and amperage required TBD by system requirements.

Notes:

- Opening shall receive all components necessary to electronically lock and unlock the door.
- The status of the door shall be monitored via the existing access control software.
- The condition of the door shall be programmable within the software to lock and/or unlock according to the predefined time-zones within the software.
- Upon a forced door and/or door held condition the software shall initiate an alarm to alert the Auburn University Department of Campus Safety & Security of the condition of the door.
- The door must be capable of real-time remote programming and monitoring.

**SET: SH-06.00**

Opening Type: Electrified Mortise Lockset – Exit Only

Opening with Mortise Lockset: used for egress only. Free egress at all times.

QTY	TYPE	DESCRIPTION	FINISH	MFR
1	45HW15H626RH DS RQE C <sup>(1)</sup>	Wired Lockset: w/ DS, RQE & Quick Connects	TBD <sup>(2)</sup>	BES
1	EPT-12C <sup>(1)</sup>	Power Transfer w/ Quick Connects	TBD <sup>(2)</sup>	STA
3	3CB1HWx4.5x4.5 <sup>(1)</sup>	Butt Hinges	26D <sup>(2)</sup>	IVE
1	4040XP <sup>(1)</sup>	Door Closer	TBD <sup>(2)</sup>	LCN
1	WH-38 <sup>(1)(3)</sup>	38” Quick Connect Lock to EPT Harness	N/A	STA
1	WH-192P <sup>(1)(3)</sup>	192” Quick Connect EPT to JB Harness	N/A	STA

<sup>(1)</sup> Exact part number TBD upon door survey

<sup>(2)</sup> Finish TBD upon door survey. Preferred finishes are Satin Chrome or Dark Bronze

<sup>(3)</sup> Wiring harnesses are used to connect the door hardware (mortise lockset) to the EPT and from the EPT to the junction box. Consult door manufacturer for harness length requirements.

Notes:

- Opening shall receive all components necessary for the status of the door to be monitored via the existing access control software.
- Upon a forced door and/or door held condition the software shall initiate an alarm to alert the Auburn University Department of Campus Safety & Security of the condition of the door.
- The door must be capable of real-time remote monitoring.

**SET: SH-07.00**

Opening Type: Stairwell Electrified Panic Device – With Reader

Opening with reader and panic-device hardware used in a stairwell or fire rated corridor entry. Used as an ingress and egress point during both normal operational hours and afterhours access. Free egress at all times.

QTY	TYPE	DESCRIPTION	FINISH	MFGR
1	READER <sup>(4)</sup>	Mobile Enabled Multi-Technology Reader	BLK <sup>(2)</sup>	SCE
1	1076 <sup>(1)</sup>	Door Contact	TBD <sup>(2)</sup>	SEN
1	Trove3m3	Trove 3 Power Supply for Lenel Panels	N/A	ALT
1	98/99L-FxE996 WP-RX CON <sup>(1) (5) (6)</sup>	Electrified Exit Rim Device w/ Quick Connects	TBD <sup>(2)</sup>	VON
1	EPT-10-CON <sup>(1)</sup>	Power Transfer w/ Quick Connects	TBD <sup>(2)</sup>	ALG
1	112HDxEPT <sup>(1)</sup>	Continuous Hinge w/ EPT Prep	TBD <sup>(2)</sup>	IVE
1	12E72S2RP	Rim Cylinder	TBD <sup>(2)</sup>	BES
1	4040XP <sup>(1)</sup>	Door Closer	TBD <sup>(2)</sup>	LCN
1	CON-38 <sup>(1) (3)</sup>	38” Quick Connect Device to EPT Harness	N/A	ALG
1	CON-192P <sup>(1) (3)</sup>	192” Quick Connect EPT to JB Harness	N/A	ALG

- (1) Exact part number TBD upon door survey
- (2) Finish TBD upon door survey. Preferred finishes are Satin Chrome or Dark Bronze.
- (3) Wiring harnesses are used to connect the door hardware (exit device) to the EPT and from the EPT to the junction box. Consult door manufacturer for harness length requirements.
- (4) Schlage MTB11 for Mullion Mount, MTB15 for Wall Mount set to Auburn University Configuration.
- (5) 06 Lever is preferred.
- (6) Fail Safe.

Notes:

- Opening shall receive all components necessary to electronically lock and unlock the door and to allow entry with a valid Auburn University credential.
- Door Hardware shall always allow free egress.
- The status of the door shall be monitored via the existing access control software.
- The condition of the door shall be programmable within the software to lock and/or unlock according to the predefined time-zones within the software.
- Upon a forced door and/or door held condition the software shall initiate an alarm to alert the Auburn University Department of Campus Safety & Security of the condition of the door.
- The door must be capable of real-time remote programming and monitoring.
- The door power supply must be connected to the Fire Alarm System and unlock, while maintaining positive latching, during an egress event per Life Safety Requirements.
- E996L trim to be phased out and replaced by M996L.

**SET: SH-08.00**

Opening Type: Overhead Coiling Door - Monitored

Overhead roll-up door monitored only

QTY	TYPE	DESCRIPTION	FINISH	MFR
1	2207A-L <sup>(1)</sup>	Door Contact	TBD <sup>(1)</sup>	GE

<sup>(1)</sup> Exact part number TBD upon door survey

Notes:

- Opening shall receive all components necessary in order for the status of the door to be monitored via the existing access control software.
- Upon a forced door and/or door held condition the software shall initiate an alarm to alert the Auburn University Department of Campus Safety & Security of the condition of the door.
- The door must be capable of real-time remote monitoring.

**SET: ADA-01.00**

Opening Type: Standard ADA Access Point

ADA entrance door vestibule with panic-device hardware and ADA bollard (if required in the specific application) containing a Mobile/Bluetooth Enabled Multi-Technology Reader and an ADA actuator. Used as an ingress and egress point during both normal operational hours and afterhours access. Free egress at all times.

QTY	TYPE	DESCRIPTION	FINISH	MFGR
1	READER <sup>(4)</sup>	Mobile/Bluetooth Enabled Multi-Technology Reader	BLK <sup>(2)</sup>	SCE
1	1076 <sup>(1)</sup>	Door Contact	TBD <sup>(2)</sup>	SEN
1 <sup>(6)</sup>	STRIKEIT4 <sup>(1)</sup>	StrikeIt4 Power Supply	N/A	ALT
1	98/99 QEL WP-RX CON <sup>(1)</sup>	Electrified Exit Rim Device w/ Quick Connects	TBD <sup>(2)</sup>	VON
1	PULL TRIM <sup>(1)</sup>	Pull Trim	TBD <sup>(2)</sup>	TBD
1	EPT-10-CON <sup>(1)</sup>	Power Transfer w/ Quick Connects	TBD <sup>(2)</sup>	ALG
1	112HDxEPT <sup>(1)</sup>	Continuous Hinge w/ EPT Prep	TBD <sup>(2)</sup>	IVE
1	12E72S2RP	Rim Cylinder	TBD <sup>(2)</sup>	BES
2	4642 REG <sup>(1)</sup>	ADA Door Operator	TBD <sup>(2)</sup>	LCN
1	CON-38 <sup>(1)(3)</sup>	38" Quick Connect Device to EPT Harness	N/A	ALG
1	CON-192P <sup>(1)(3)</sup>	192" Quick Connect EPT to JB Harness	N/A	ALG
1	CE-916 <sup>(1)(5)</sup>	ADA Bollard	DBZ	CUR
4	I36 <sup>(1)</sup>	INGRESS'R Actuator	TBD <sup>(2)</sup>	WIKK

- (1) Exact part number TBD upon door survey
- (2) Finish TBD upon door survey. Preferred finishes are Satin Chrome or Dark Bronze.
- (3) Wiring harnesses are used to connect the door hardware (exit device) to the EPT and from the EPT to the junction box. Consult door manufacturer for harness length requirements.
- (4) Schlage MTB11 for Mullion Mount, MTB15 for Wall Mount set to Auburn University Configuration.
- (5) Bollard (if required) should be ordered without factory cutouts and must be field prepped.
- (6) Quantity TBD upon door survey

Vestibule of less than 8 feet from door to door Schematics: ADA-01.11 & ADA-01.12      Vestibule of greater than 8 feet from door to door Schematics: ADA-01.21 & ADA-01.22

Notes:

- Opening shall receive all components necessary in order to electronically lock and unlock the door remotely and to allow entry with a valid Auburn University credential.
- Door Hardware shall allow free egress at all times.
- An access granted event using an Auburn University Mobile Credential will unlock the device and allow the actuator to be used to open the door.
- An access granted event using a valid Auburn University ADA Bluetooth Credential will unlock the device as well as activate the ADA operator to open the door.
- The status of the door shall be monitored via the existing access control software.
- The condition of the door shall be programmable within the software to lock and/or unlock according to the predefined time-zones within the software.
- Upon a forced door and/or door held condition the software shall initiate an alarm to alert the Auburn University Department of Campus Safety & Security of the condition of the door.
- The door must be capable of real-time remote programming and monitoring.
- Depending on the vestibule size will denote wiring and configuration requirements set by the Auburn University Office of Accessibility.

**SET: ADA-02.00**

Opening Type: Standard Single ADA Access Point

ADA entrance, without vestibule, door with panic-device hardware and ADA bollard (if required in the specific application) containing Mobile/Bluetooth Enabled Multi-Technology Reader and an ADA actuator. Used as an ingress and egress point during both normal operational hours and afterhours access. Free egress at all times.

QTY	TYPE	DESCRIPTION	FINISH	MFR
1	READER <sup>(4)</sup>	Mobile/Bluetooth Enabled Multi-Technology Reader	BLK <sup>(2)</sup>	SCE
1	1076 <sup>(1)</sup>	Door Contact	TBD <sup>(2)</sup>	SEN
1 <sup>(6)</sup>	STRIKEIT4 <sup>(1)</sup>	StrikeIt4 Power Supply	N/A	ALT
1	98/99 QEL WP-RX CON <sup>(1)</sup>	Electrified Exit Rim Device w/ Quick Connects	TBD <sup>(2)</sup>	VON
1	PULL TRIM <sup>(1)</sup>	Pull Trim	TBD <sup>(2)</sup>	TBD
1	EPT-10-CON <sup>(1)</sup>	Power Transfer w/ Quick Connects	TBD <sup>(2)</sup>	ALG
1	112HDxEPT <sup>(1)</sup>	Continuous Hinge w/ EPT Prep	TBD <sup>(2)</sup>	IVE
1	12E72S2RP	Rim Cylinder	TBD <sup>(2)</sup>	BES
1	4642 REG <sup>(1)</sup>	ADA Door Operator	TBD <sup>(2)</sup>	LCN
1	CON-38 <sup>(1) (3)</sup>	38" Quick Connect Device to EPT Harness	N/A	ALG
1	CON-192P <sup>(1) (3)</sup>	192" Quick Connect EPT to JB Harness	N/A	ALG
1	CE-916 <sup>(1) (5)</sup>	ADA Bollard	DBZ	CUR
2	I36 <sup>(1)</sup>	INGRESS'R Actuator	TBD <sup>(2)</sup>	WIKK

- <sup>(1)</sup> Exact part number TBD upon door survey
- <sup>(2)</sup> Finish TBD upon door survey. Preferred finishes are Satin Chrome or Dark Bronze.
- <sup>(3)</sup> Wiring harnesses are used to connect the door hardware (exit device) to the EPT and from the EPT to the junction box. Consult door manufacturer for harness length requirements.
- <sup>(4)</sup> Reader must be set to reader track 2
- <sup>(5)</sup> Bollard (if required) should be ordered without factory cutouts and must be field prepped.
- <sup>(6)</sup> Quantity TBD upon door survey

Notes:

- Opening shall receive all components necessary in order to electronically lock and unlock the door remotely and to allow entry with a valid Auburn University credential.
- Door Hardware shall allow free egress at all times.
- An access granted event using an Auburn University Mobile Credential will unlock the device and allow the actuator to be used to open the door.
- An access granted event using a valid Auburn University ADA Bluetooth Credential will unlock the device as well as activate the ADA operator to open the door.
- The status of the door shall be monitored via the existing access control software.
- The condition of the door shall be programmable within the software to lock and/or unlock according to the predefined time-zones within the software.
- Upon a forced door and/or door held condition the software shall initiate an alarm to alert the Auburn University Department of Campus Safety & Security of the condition of the door.
- The door must be capable of real-time remote programming and monitoring.

**SET: ADA-03.00**

Opening Type: Standard Single ADA Access Point

ADA entrance door with ADA actuator. Used as an ingress and egress point during both normal operational hours and afterhours access. Free Ingress at all times. Free egress at all times.

QTY	TYPE	DESCRIPTION	FINISH	MFGR
1	PUSH/PULL TRIM <sup>(1)</sup>	Push/Pull Trim	TBD <sup>(2)</sup>	TBD
1	112HD <sup>(1)</sup>	Continuous Hinge	TBD <sup>(2)</sup>	IVE
1	4642 REG <sup>(1)</sup>	ADA Door Operator	TBD <sup>(2)</sup>	LCN
2	I36 <sup>(1)</sup>	INGRESS'R Actuator	TBD <sup>(2)</sup>	WIKK

<sup>(1)</sup> Exact part number TBD upon door survey

<sup>(2)</sup> Finish TBD upon door survey. Preferred finishes are Satin Chrome or Dark Bronze.

Notes:

- Opening shall receive all components necessary in order to allow the actuator to be used to open the door.
- This opening does not have locking door hardware.

**SET: TS-01.00**

Opening Type: Tornado Shelter – Single Door

Opening within the Buildings designated shelter with positive latching panic-device hardware. Used for emergency sheltering only. Free ingress at all times. Free egress at all times.

QTY	TYPE	DESCRIPTION	FINISH	MFGR
1	WS9957L-Fx996L-BE (#06)	<sup>(1)</sup> <sup>(4)</sup> Tornado Tested Three-point Latching Panic Device	TBD <sup>(2)</sup>	VON
1	224XY	Continuous Hinge	TBD <sup>(2)</sup>	IVE
1	4040XP <sup>(1)</sup>	Door Closer	TBD <sup>(2)</sup>	LCN
1	SEM7800 <sup>(3)</sup>	Electromagnetic Door Holder	TBD <sup>(2)</sup>	LCN

- <sup>(1)</sup> Exact part number TBD upon door survey
- <sup>(2)</sup> Finish TBD upon door survey. Preferred finishes are Satin Chrome or Dark Bronze
- <sup>(3)</sup> Reference AU Standards for Electrical and Fire Life Safety for specific Part Number and proper connection to the Fire Alarm System.
- <sup>(4)</sup> 06 Lever is preferred

Notes:

- Opening shall receive all components necessary in order for the door to be held open by the Electromagnetic Door Holder during normal operation.
- Upon a weather event the Electromagnetic Door Holder can be remotely released by the Auburn University Department of Campus Safety & Security and returned to normal operation once the event has ended.
- The door is not capable of being locked.

**SET: TS-02.00**

Opening Type: Tornado Shelter – Double Door

Double-door opening within the buildings designated shelter with positive latching panic-device hardware. Used for emergency sheltering only. Free ingress at all times. Free egress at all times.

QTY	TYPE	DESCRIPTION	FINISH	MFGR
2	WS9927L-Fx996L-BE (#06)	<sup>(1), (4)</sup> Tornado Tested Panic Device	TBD <sup>(2)</sup>	VON
2	224XY	Continuous Hinge	TBD <sup>(2)</sup>	IVE
2	4040XP <sup>(1)</sup>	Door Closer	TBD <sup>(2)</sup>	LCN
2	137NA	Astragal	TBD <sup>(2)</sup>	NGP
2	SEM7850 <sup>(3)</sup>	Electromagnetic Holder	TBD <sup>(2)</sup>	LCN

- <sup>(1)</sup> Exact part number TBD upon door survey
- <sup>(2)</sup> Finish TBD upon door survey. Preferred finishes are Satin Chrome or Dark Bronze
- <sup>(3)</sup> Reference AU Standards for Electrical and Fire Life Safety for specific Part Number and proper connection to the Fire Alarm System.
- <sup>(4)</sup> 06 Lever is preferred

Notes:

- Opening shall receive all components necessary in order for the door to be held open by the Electromagnetic Door Holder during normal operation.
- Upon a weather event the Electromagnetic Door Holder can be remotely released by the Auburn University Department of Campus Safety & Security and returned to normal operation once the event has ended.
- The door is not capable of locking.

**SET: GH-1.00**

Opening Type: Unsecured interior passage

Push/Pull Hardware used on interior vestibules

QTY	TYPE	DESCRIPTION	FINISH	MFGR
1	9190HD-24-0xNS <sup>(1)</sup>	Vestibule - Push/Pull Set	26D <sup>(3)</sup>	IVE
1	1461xREGxDELxFCxTBSRT <sup>(1)</sup>	Door Closer	AL <sup>(3)</sup>	LCN
3	3CB1HWx4.5x4.5 <sup>(1)</sup>	Butt Hinges	26D <sup>(3)</sup>	IVE

- (1) Exact part number TBD upon door survey
- (2) Finish TBD upon door survey. 626 (Satin Chrome) preferred

Notes:

- Door is never locked.
- Free egress at all times..

**SET: GH-1.50**

Opening Type: Unsecured interior passage

Push/Pull Hardware used on public restrooms.

QTY	TYPE	DESCRIPTION	FINISH	MFGR
1	PR-8303-0-US26D-4X16-G-1-3/4 <sup>(1)</sup>	Vestibule - Push/Pull Set	26D <sup>(3)</sup>	IVE
1	1461xREGxDELxFCxTBSRT <sup>(1)</sup>	Door Closer	AL <sup>(3)</sup>	LCN

- (1) Exact part number TBD upon door survey
- (2) Finish TBD upon door survey. 626 (Satin Chrome) preferred

Notes:

- Door is never locked
- Free egress at all times

**SET: GH-2.00**

Opening Type: Secure Storage and Closets

Storeroom Function Mortise Lockset used in secure closets, custodial rooms, and storage rooms.

QTY	TYPE	DESCRIPTION	FINISH	MFGR
1	45H-7D15H2626 <sup>(1)(2)</sup>	Mortise Lockset	626 <sup>(3)</sup>	BES
1	1461xREGxDELxFCxTBSRT <sup>(1)</sup>	Door Closer	AL <sup>(3)</sup>	LCN
3	3CB1HWx4.5x4.5 <sup>(1)</sup>	Butt Hinges	26D <sup>(3)</sup>	IVE

- <sup>(1)</sup> Exact part number TBD upon door survey
- <sup>(2)</sup> 15 Lever is preferred
- <sup>(3)</sup> Finish TBD upon door survey. 626 (Satin Chrome) is preferred

Notes:

- Door is never unlocked.
- Access by key from outside.
- Free egress at all times.

**SET: GH-3.00**

Opening Type: Private Restrooms

Privacy Function Mortise Lockset for private restrooms, mother's rooms.

QTY	TYPE	DESCRIPTION	FINISH	MFGR
1	45H-0L15H2626 <sup>(1)(2)</sup>	Mortise Lockset	626 <sup>(3)</sup>	BES
1	1461xREGxDELxFCxTBSRT <sup>(1)</sup>	Door Closer	AL <sup>(3)</sup>	LCN
3	3CB1HWx4.5x4.5 <sup>(1)</sup>	Butt Hinges	26D <sup>(3)</sup>	IVE

- <sup>(1)</sup> Exact part number TBD upon door survey
- <sup>(2)</sup> 15 Lever is preferred
- <sup>(3)</sup> Finish TBD upon door survey. 626 (Satin Chrome) is preferred

Notes:

- Lockable from inside only.
- Visual indication of occupancy.
- Free egress at all times.

**SET: GH-4.00**

Opening Type: Office Main Entry Point

Office Function Mortise Lockset for office applications

QTY	TYPE	DESCRIPTION	FINISH	MFGR
1	45H-7AB15H2626 <sup>(1)(2)</sup>	Mortise Lockset	626 <sup>(3)</sup>	BES
3	3CB1HWx4.5x4.5 <sup>(1)</sup>	Butt Hinges	26D <sup>(3)</sup>	IVE

- <sup>(1)</sup> Exact part number TBD upon door survey
- <sup>(2)</sup> 15 Lever is preferred
- <sup>(3)</sup> Finish TBD upon door survey. 626 (Satin Chrome) is preferred

Notes:

- Access by key from outside.
- May be locked from either side.
- Maybe unlocked from either side.
- Free egress at all times.
- Door closer can be added as desired.

**SET: GH-5.00**

Opening Type: Unsecured Closet

Passage Function Mortise Lockset for use in unsecured closet applications

QTY	TYPE	DESCRIPTION	FINISH	MFGR
1	45H-0N15H2626 <sup>(1)(2)</sup>	Mortise Lockset	626 <sup>(3)</sup>	BES
1	1461xREGxDELxFCxTBSRT <sup>(1)</sup>	Door Closer	AL <sup>(3)</sup>	LCN
3	3CB1HWx4.5x4.5 <sup>(1)</sup>	Butt Hinges	26D <sup>(3)</sup>	IVE

- <sup>(1)</sup> Exact part number TBD upon door survey
- <sup>(2)</sup> 15 Lever is preferred
- <sup>(3)</sup> Finish TBD upon door survey. 626 (Satin Chrome) is preferred

Notes:

- Door is never locked.
- Free egress at all times.

**SET: GH-6.00**

Opening Type: Dormitory Suite Main Entrance

Dormitory Function Mortise Lockset for entry into main door of dormitory suite.

QTY	TYPE	DESCRIPTION	FINISH	MFGR
1	45H-7TD15H2626 <sup>(1)(2)</sup>	Mortise Lockset	626 <sup>(3)</sup>	BES
1	1461xREGxDELxFCxTBSRT <sup>(1)</sup>	Door Closer	AL <sup>(3)</sup>	LCN
3	3CB1HWx4.5x4.5 <sup>(1)</sup>	Butt Hinges	26D <sup>(3)</sup>	IVE

- <sup>(1)</sup> Exact part number TBD upon door survey
- <sup>(2)</sup> 15 Lever is preferred
- <sup>(3)</sup> Finish TBD upon door survey. 626 (Satin Chrome) is preferred

Notes:

- Access by key from outside.
- Door is never unlocked.
- Free egress at all times.

**SET: GH-7.00**

Opening Type: Unsecured Stairwell Passage

Stairwell Passage Function Panic Hardware for unsecured stairwell access point applications

QTY	TYPE	DESCRIPTION	FINISH	MFGR
1	98L-BE-Fx996L-BE (#06) <sup>(1)(2)</sup>	Rim Exit Device	26D <sup>(3)</sup>	VON
1	4040XP <sup>(1)</sup>	Door Closer	AL <sup>(3)</sup>	LCN
3	3CB1HWx4.5x4.5 <sup>(1)</sup>	Butt Hinges	26D <sup>(3)</sup>	IVE

- <sup>(1)</sup> Exact part number TBD upon door survey
- <sup>(2)</sup> 06 Lever is preferred
- <sup>(3)</sup> Finish TBD upon door survey. 626 (Satin Chrome) is preferred

Notes:

- Door is never locked.
- Door is positive latching at all times.
- Free ingress at all times.
- Free egress at all times.

**SET: GH-8.00**

Opening Type: Single Corridor – Smoke/Fire Panic Hardware

Single Corridor Door – Smoke/Fire Panic Hardware

QTY	TYPE	DESCRIPTION	FINISH	MFGR
1	9849Fx996L-BE (#06) <sup>(1)(2)</sup>	Exit Device	26D <sup>(3)</sup>	VON
1	4040XP <sup>(1)</sup>	Door Closer	AL <sup>(3)</sup>	LCN
3	3CB1HWx4.5x4.5 <sup>(1)</sup>	Butt Hinges	26D <sup>(3)</sup>	IVE
1	SEM7800 <sup>(4)</sup>	Electromagnetic Door Holder	TBD <sup>(3)</sup>	LCN

<sup>(1)</sup> Exact part number TBD upon door survey

<sup>(2)</sup> 06 Lever is preferred

<sup>(3)</sup> Finish TBD upon door survey. 626 (Satin Chrome) is preferred

<sup>(4)</sup> Reference AU Standards for Electrical and Fire Life Safety for specific Part Number and proper connection to the Fire Alarm System.

Notes:

- Opening shall receive all components necessary in order for the door to be held open by the Electromagnetic Door Holder during normal operation.
- Upon a Fire Alarm event the Electromagnetic Door Holder will release automatically.
- Door is never locked.
- Door is positive latching at all times.
- Free ingress at all times.
- Free egress at all times.

**SET: GH-9.00**

Opening Type: Double Corridor Door – Smoke/Fire Panic Hardware

Double Corridor Door – Smoke/Fire Panic Hardware

QTY	TYPE	DESCRIPTION	FINISH	MFGR
2	9849Fx996L-BE (#06) <sup>(1)(2)</sup>	Exit Device	26D <sup>(3)</sup>	VON
2	4040XP <sup>(1)</sup>	Door Closer	AL <sup>(3)</sup>	LCN
6	3CB1HWx4.5x4.5 <sup>(1)</sup>	Butt Hinges	26D <sup>(3)</sup>	IVE
2	SEM7800 <sup>(4)</sup>	Electromagnetic Door Holder	TBD <sup>(3)</sup>	LCN

<sup>(1)</sup> Exact part number TBD upon door survey

<sup>(2)</sup> 06 Lever is preferred

<sup>(3)</sup> Finish TBD upon door survey. 626 (Satin Chrome) is preferred

<sup>(4)</sup> Reference AU Standards for Electrical and Fire Life Safety for specific Part Number and proper connection to the Fire Alarm System.

Notes:

- Opening shall receive all components necessary in order for the doors to be held open by the Electromagnetic Door Holders during normal operation.
- Upon a Fire Alarm event the Electromagnetic Door Holders will release automatically.
- Doors are never locked.
- Doors are positive latching at all times.
- Free ingress at all times.
- Free egress at all times.

**SET: GH-10.00**

Opening Type: Dormitory Bedroom Entry

Dormitory Function Cylindrical Lockset for individual bedrooms

QTY	TYPE	DESCRIPTION	FINISH	MFGR
1	93K7A15DS3626 <sup>(1)(2)</sup>	Cylindrical Lockset	626 <sup>(3)</sup>	BES
3	3CB1HWx4.5x4.5 <sup>(1)</sup>	Butt Hinges	26D <sup>(3)</sup>	IVE

- (1) Exact part number TBD upon door survey
- (2) 15 Lever is preferred
- (3) Finish TBD upon door survey. 626 (Satin Chrome) is preferred

Notes:

- Access by key from outside.
- May be locked by turning the inside button.
- May be unlocked by turning the inside button.
- Free egress at all times.

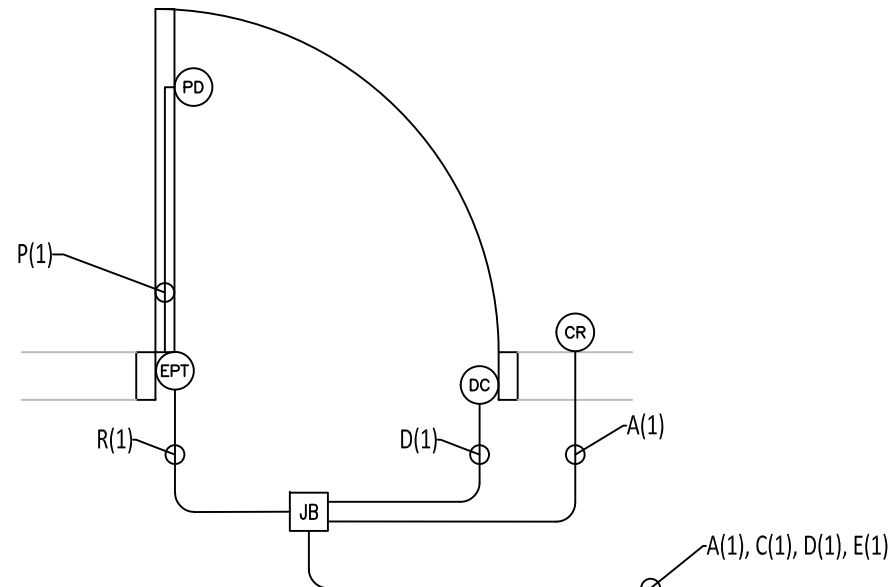

CABLE LEGEND			
A	24ga. 1pr. SHIELDED + 18ga. 2c UNSHIELDED OSDP CMP	K	
B	24ga. 2c SHIELDED 120 Ohm OSDP CMP	L	
C	22ga. 4c UNSHIELDED	M	
D	22ga. 2c UNSHIELDED CMR	N	
E	18ga. 2c UNSHIELDED	P	QUICK CONNECT HARNESS <sup>(1)</sup>
F		R	QUICK CONNECT HARNESS <sup>(1)</sup>
G		S	
H		T	
J			

All manufactures recommendations for cable wire gauge per run length shall be followed, no exceptions.  
 (1) See Hardware Schedule for Harness part number.

- QTY. SECURITY MATERIALS
- 1 CREDENTIAL READER - CR
  - 1 DOOR CONTACT - DC
  - 1 ELECTRIFIED QL RIM PANIC DEVICE - PD
  - 1 PANIC DEVICE POWER SUPPLY - PDPS
  - 1 ELECTRIC POWER TRANSFER - EPT
  - 2 QUICK CONNECT WIRE HARNESS
- \*SEE HARDWARE SCHEDULE FOR FULL PRODUCT DETAILS AND PART NUMBERS. \*

TO NEAREST CABLE TRAY OR HOME RUN  
 TO SECURITY/ACCESS CONTROL ROOM ON  
 THE CORRESPONDING FLOOR

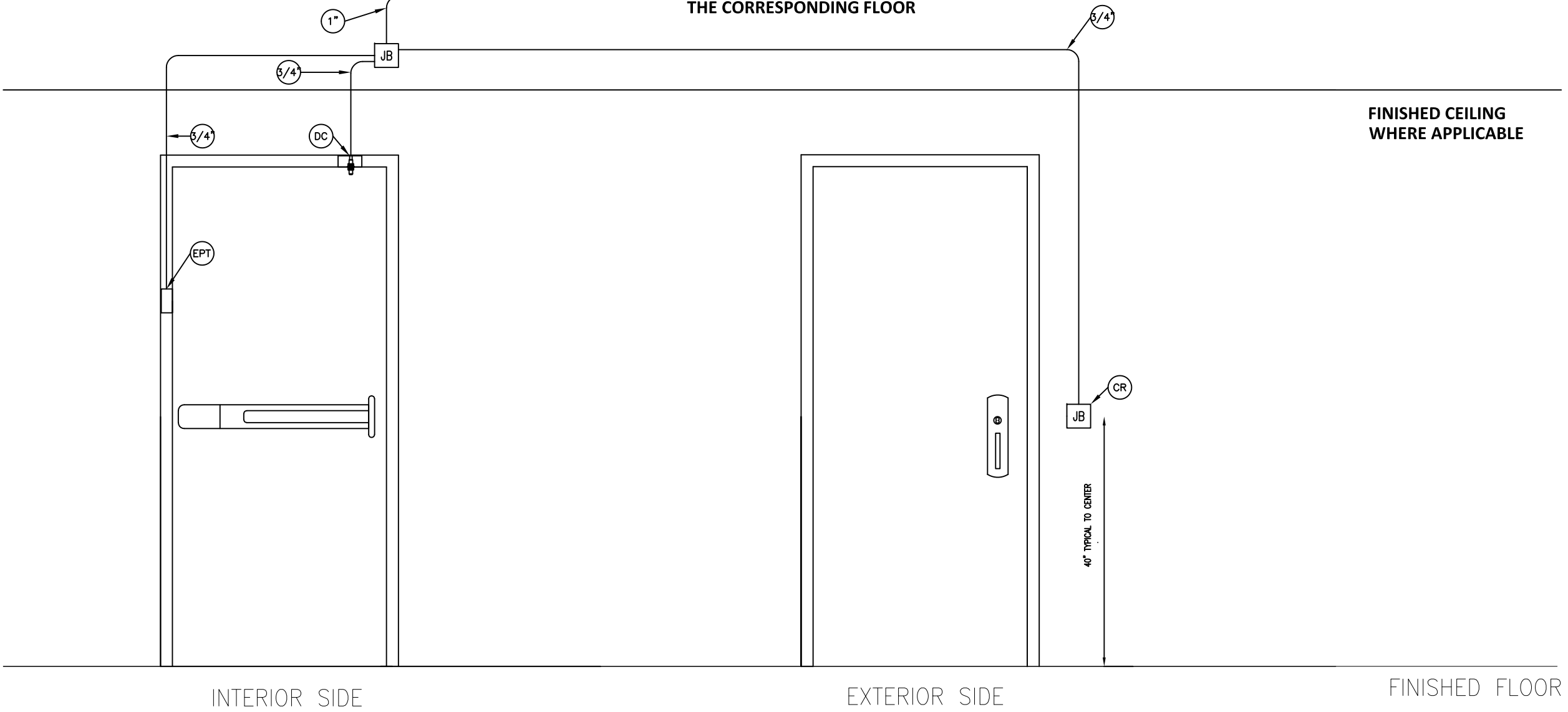

SH  
01.00

ELEVATION VIEW: ELECTRIFIED PANIC DEVICE - WITH READER DETAIL  
 NOT TO SCALE

Date: 20230301  
 Dwg. No.: SH-01.00  
 ELEVATION VIEW: ELECTRIFIED PANIC DEVICE - WITH READER DETAIL

AUBURN UNIVERSITY - DESIGN AND CONSTRUCTION STANDARDS

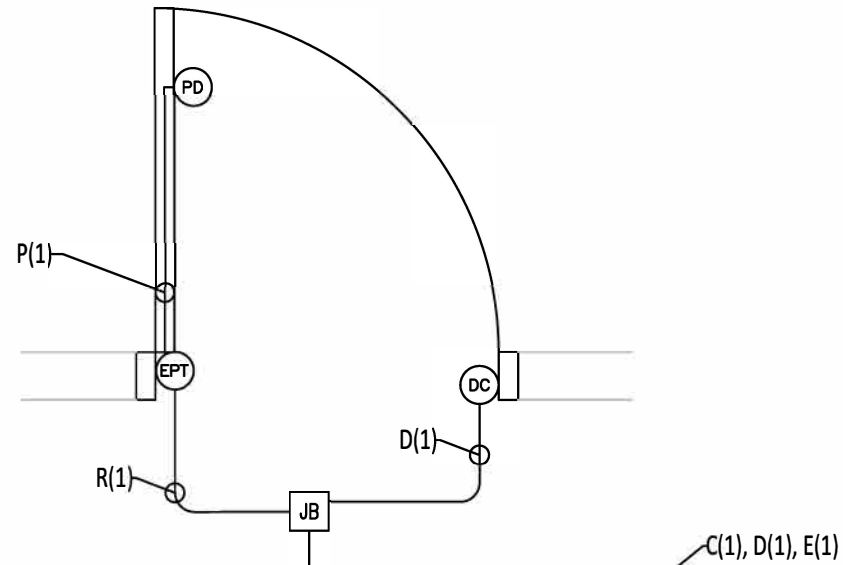

CABLE LEGEND		
A	24ga. 1pr. SHIELDED + 18ga. 2c UNSHIELDED OSDP CMP	K
B	24ga. 2c SHIELDED 120 Ohm OSDP CMP	L
C	22ga. 4c UNSHIELDED	M
D	22ga. 2c UNSHIELDED CMR	N
E	18ga. 2c UNSHIELDED	P
F		R
G		S
H		T
J		

All manufactures recommendations for cable wire gauge per run length shall be followed, no exceptions.  
 (1) See Hardware Schedule for Harness part number.

QTY.	SECURITY MATERIALS
1	DOOR CONTACT - DC
1	ELECTRIFIED QL RIM PANIC DEVICE - PD
1	PANIC DEVICE POWER SUPPLY - PDPS
1	ELECTRIC POWER TRANSFER - EPT
2	QUICK CONNECT WIRE HARNESS

\*SEE HARDWARE SCHEDULE FOR FULL PRODUCT DETAILS AND PART NUMBERS. \*

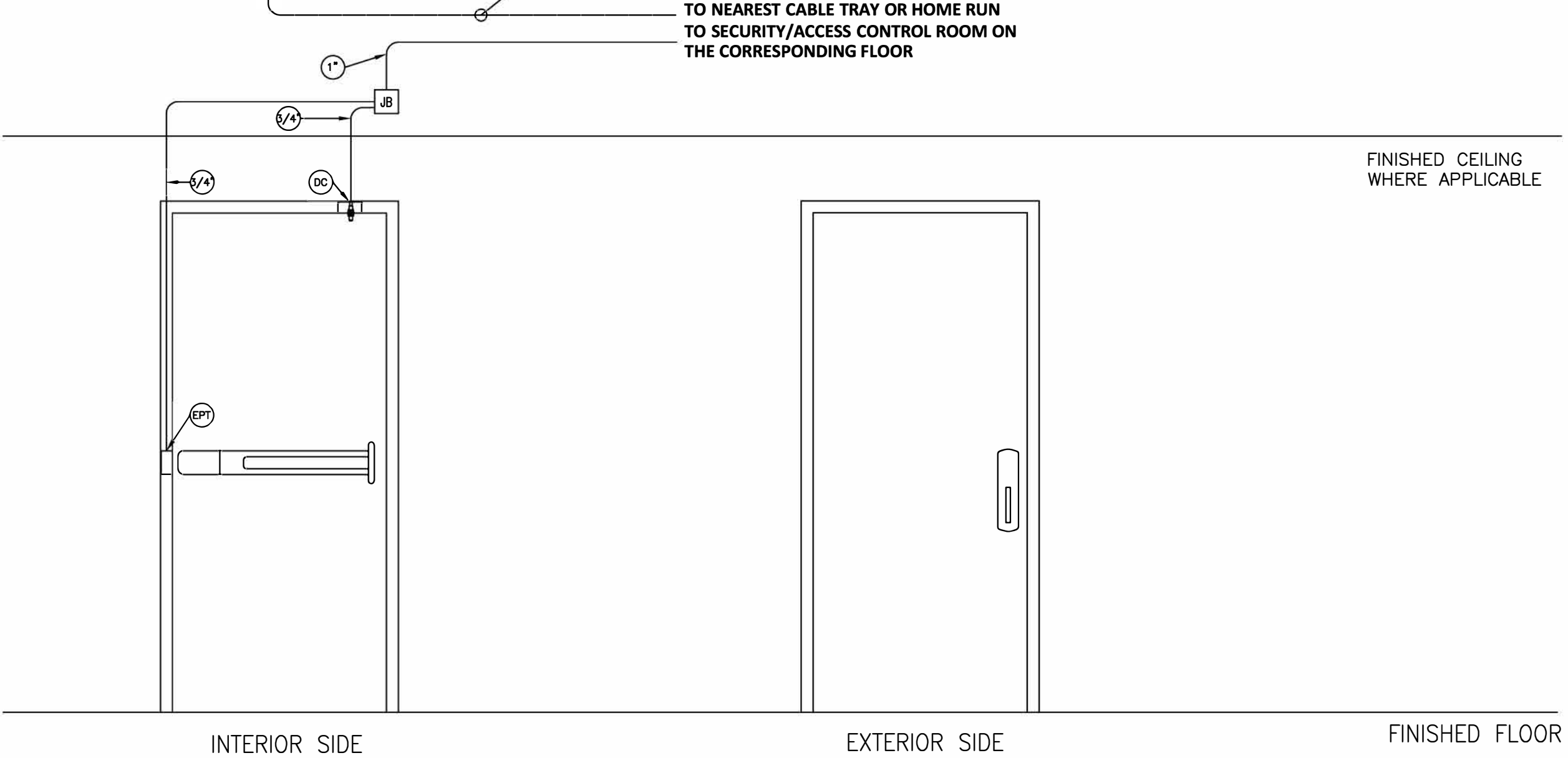

Date: 20230301

Dwg. No.: SH-02.00

ELEVATION VIEW: ELECTRIFIED PANIC DEVICE - NO READER DETAIL

AUBURN UNIVERSITY - DESIGN AND CONSTRUCTION STANDARDS

SH  
02.00

ELEVATION VIEW: ELECTRIFIED PANIC DEVICE - NO READER DETAIL  
 NOT TO SCALE

2025 Door Hardware Standards

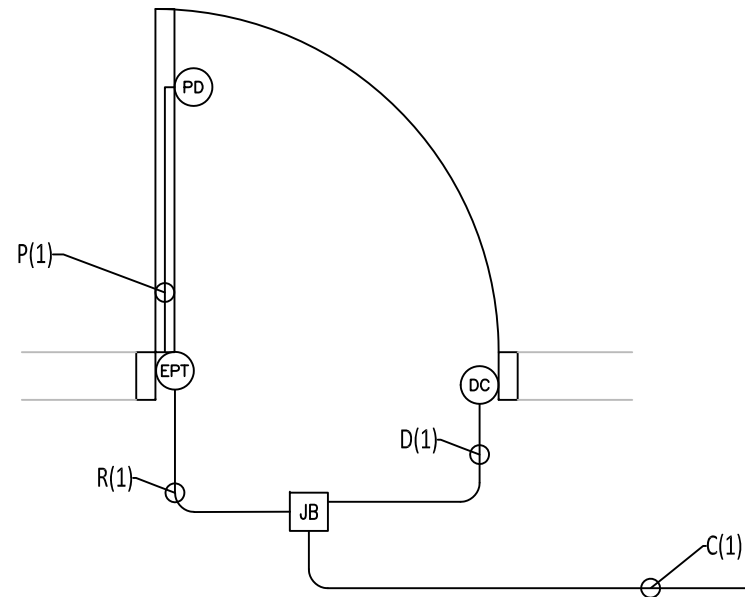

CABLE LEGEND		
A	24ga. 1pr. SHIELDED + 18ga. 2c UNSHIELDED OSDP CMP	K
B	24ga. 2c SHIELDED 120 Ohm OSDP CMP	L
C	22ga. 4c UNSHIELDED	M
D	22ga. 2c UNSHIELDED CMR	N
E	18ga. 2c UNSHIELDED	P QUICK CONNECT HARNESS <sup>(1)</sup>
F		R QUICK CONNECT HARNESS <sup>(1)</sup>
G		S
H		T
J		

- QTY. SECURITY MATERIALS
- 1 DOOR CONTACT - DC
  - 1 EO RIM PANIC DEVICE - PD
  - 1 ELECTRIC POWER TRANSFER - EPT
  - 2 QUICK CONNECT WIRE HARNESS

\*SEE HARDWARE SCHEDULE FOR FULL PRODUCT DETAILS AND PART NUMBERS. \*

All manufactures recommendations for cable wire gauge per run length shall be followed, no exceptions.  
 (1) See Hardware Schedule for Harness part number.

TO NEAREST CABLE TRAY OR HOME RUN  
 TO SECURITY/ACCESS CONTROL ROOM ON  
 THE CORRESPONDING FLOOR

FINISHED CEILING  
 WHERE APPLICABLE

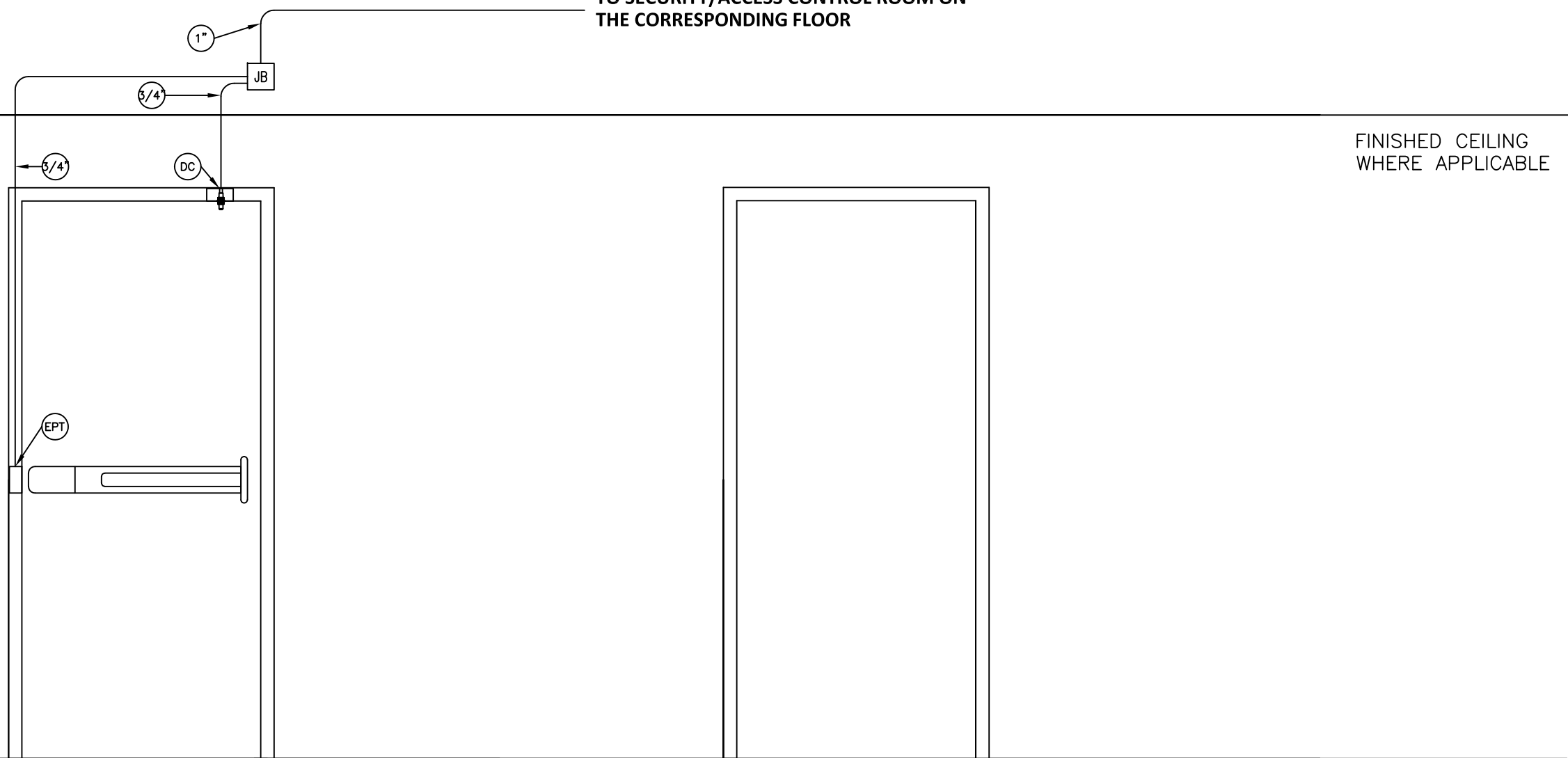

INTERIOR SIDE

EXTERIOR SIDE

FINISHED FLOOR

SH  
03.00

ELEVATION VIEW: MONITORED PANIC DEVICE - EXIT ONLY DETAIL  
 NOT TO SCALE

2025 Door Hardware Standards

ELEVATION VIEW: SINGLE DOOR WITH EXIT ONLY PANIC DEVICE - MONITORED  
 DETAIL

Date: 20230301

Dwg. No.: SH-03.00

AUBURN UNIVERSITY - DESIGN AND CONSTRUCTION STANDARDS

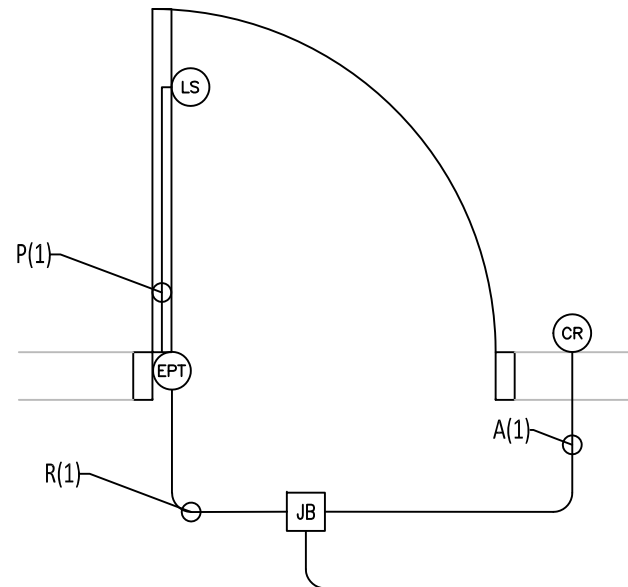

CABLE LEGEND		
A	24ga. 1pr. SHIELDED + 18ga. 2c UNSHIELDED OSDP CMP	K
B	24ga. 2c SHIELDED 120 Ohm OSDP CMP	L
C	22ga. 4c UNSHIELDED	M
D	22ga. 2c UNSHIELDED CMR	N
E	18ga. 2c UNSHIELDED	P
F		R
G		S
H		T
J		

- QTY. SECURITY MATERIALS
- 1 ELECTRIFIED LOCKSET - LS
  - 1 CREDENTIAL READER - CR
  - 1 ELECTRIC POWER TRANSFER - EPT
  - 2 QUICK CONNECT WIRE HARNESS

\*SEE HARDWARE SCHEDULE FOR FULL PRODUCT DETAILS AND PART NUMBERS. \*

All manufactures recommendations for cable wire gauge per run length shall be followed, no exceptions.  
 (1) See Hardware Schedule for Harness part number.

TO NEAREST CABLE TRAY OR HOME RUN  
 TO SECURITY/ACCESS CONTROL ROOM ON  
 THE CORRESPONDING FLOOR

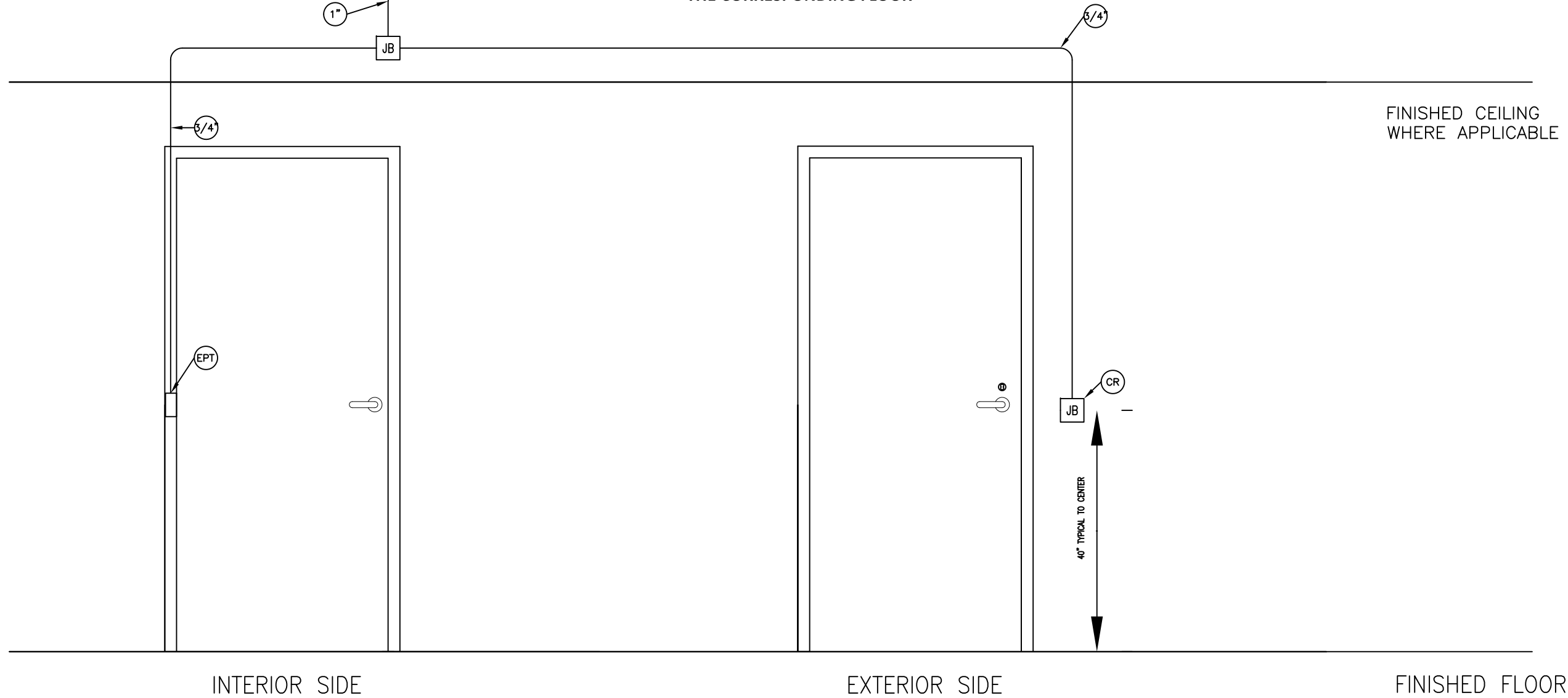

Date: 20230301

Dwg. No.: SH-04.00

ELEVATION VIEW: ELECTRIFIED MORTISE LOCK SET - WITH CARD READER DETAIL

AUBURN UNIVERSITY - DESIGN AND CONSTRUCTION STANDARDS

SH  
04.00

ELEVATION VIEW: ELECTRIFIED MORTISE LOCK SET - WITH CARD READER DETAIL  
 NOT TO SCALE

2025 Door Hardware Standards

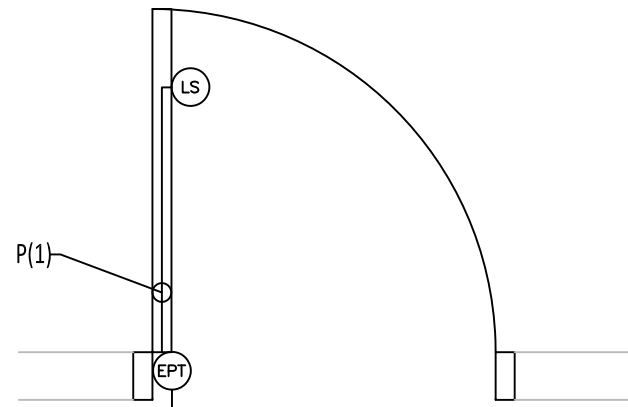

CABLE LEGEND		
A	24ga. 1pr. SHIELDED + 18ga. 2c UNSHIELDED OSDP CMP	K
B	24ga. 2c SHIELDED 120 Ohm OSDP CMP	L
C	22ga. 4c UNSHIELDED	M
D	22ga. 2c UNSHIELDED CMR	N
E	18ga. 2c UNSHIELDED	P QUICK CONNECT HARNESS <sup>(1)</sup>
F		R QUICK CONNECT HARNESS <sup>(1)</sup>
G		S
H		T
J		

- QTY. SECURITY MATERIALS  
 1 ELECTRIFIED LOCKSET - LS  
 1 ELECTRIC POWER TRANSFER - EPT  
 2 QUICK CONNECT WIRE HARNESS

\*SEE HARDWARE SCHEDULE FOR FULL PRODUCT DETAILS AND PART NUMBERS. \*

All manufactures recommendations for cable wire gauge per run length shall be followed, no exceptions.

(1) See Hardware Schedule for Harness part number.

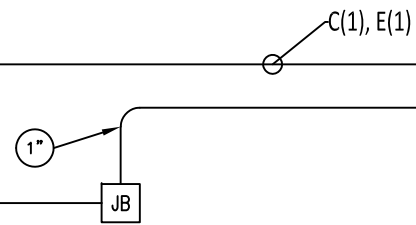

TO NEAREST CABLE TRAY OR HOME RUN  
 TO SECURITY/ACCESS CONTROL ROOM ON  
 THE CORRESPONDING FLOOR

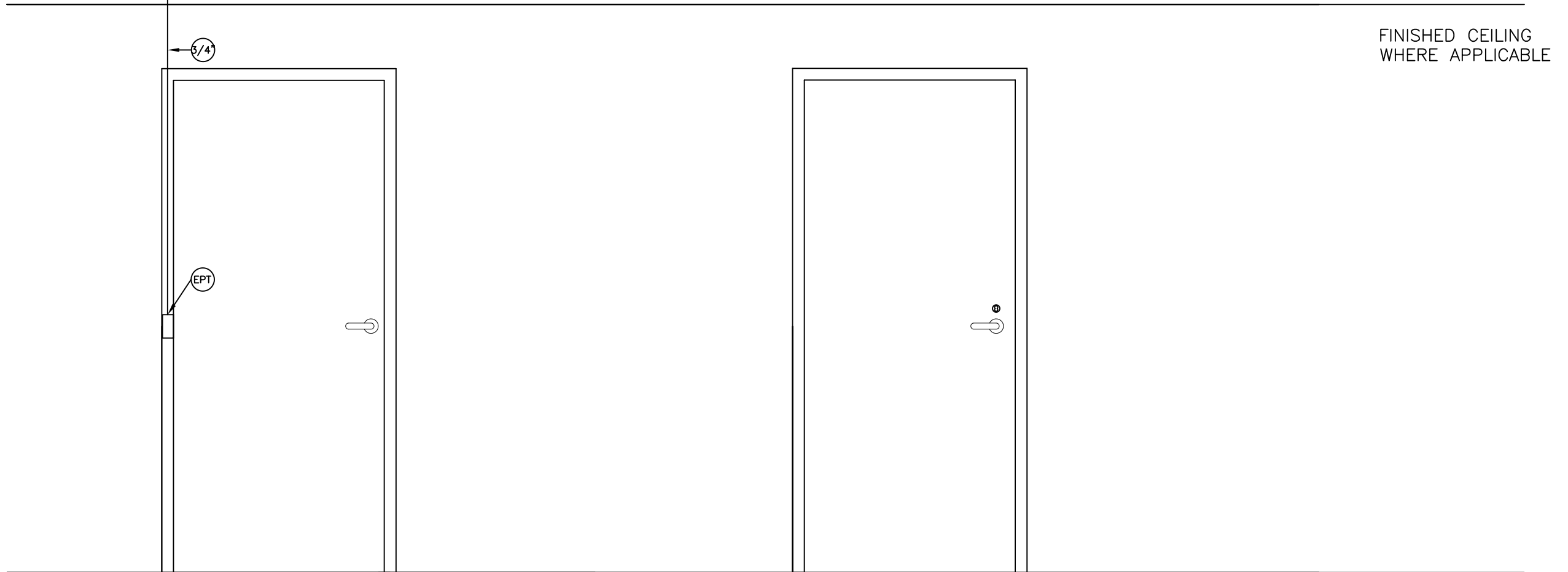

FINISHED CEILING  
 WHERE APPLICABLE

INTERIOR SIDE

EXTERIOR SIDE

FINISHED FLOOR

Date: 20230301

Dwg. No.: SH-05.00

ELEVATION VIEW: ELECTRIFIED MORTISE LOCK SET - NO READER DETAIL

AUBURN UNIVERSITY - DESIGN AND CONSTRUCTION STANDARDS

SH  
 05.00

ELEVATION VIEW: ELECTRIFIED MORTISE LOCK SET - NO READER DETAIL  
 NOT TO SCALE

2025 Door Hardware Standards

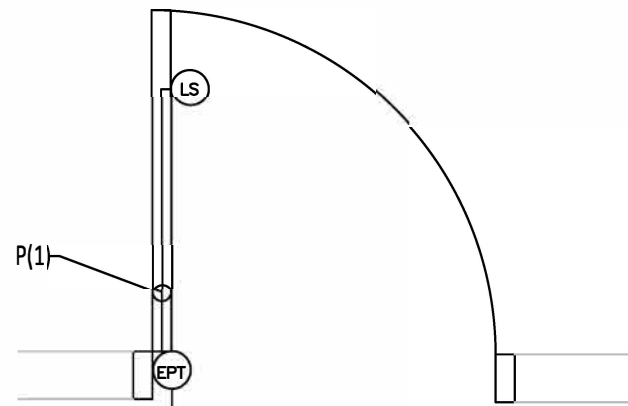

CABLE LEGEND		
A	24ga. 1pr. SHIELDED + 18ga. 2c UNSHIELDED OSDP CMP	K
B	24ga. 2c SHIELDED 120 Ohm OSDP CMP	L
C	22ga. 4c UNSHIELDED	M
D	22ga. 2c UNSHIELDED CMR	N
E	18ga. 2c UNSHIELDED	P QUICK CONNECT HARNESS (1)
F		R QUICK CONNECT HARNESS (1)
G		S
H		T
J		

- QTY. SECURITY MATERIALS  
 1 ELECTRIFIED LOCKSET - LS  
 1 ELECTRIC POWER TRANSFER - EPT  
 2 QUICK CONNECT WIRE HARNESS

\*SEE HARDWARE SCHEDULE FOR FULL PRODUCT DETAILS AND PART NUMBERS. \*

All manufactures recommendations for cable wire gauge per run length shall be followed, no exceptions.

(1) See Hardware Schedule for Harness part number.

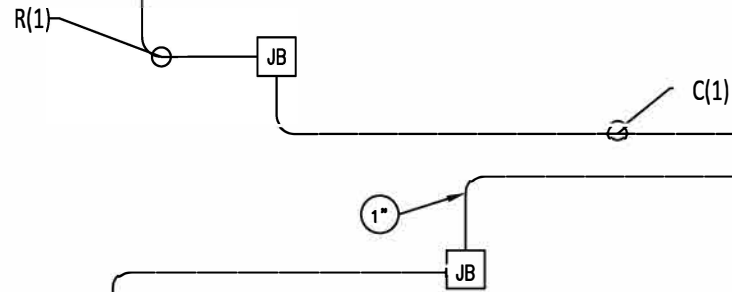

TO NEAREST CABLE TRAY OR HOME RUN  
 TO SECURITY/ACCESS CONTROL ROOM ON  
 THE CORRESPONDING FLOOR

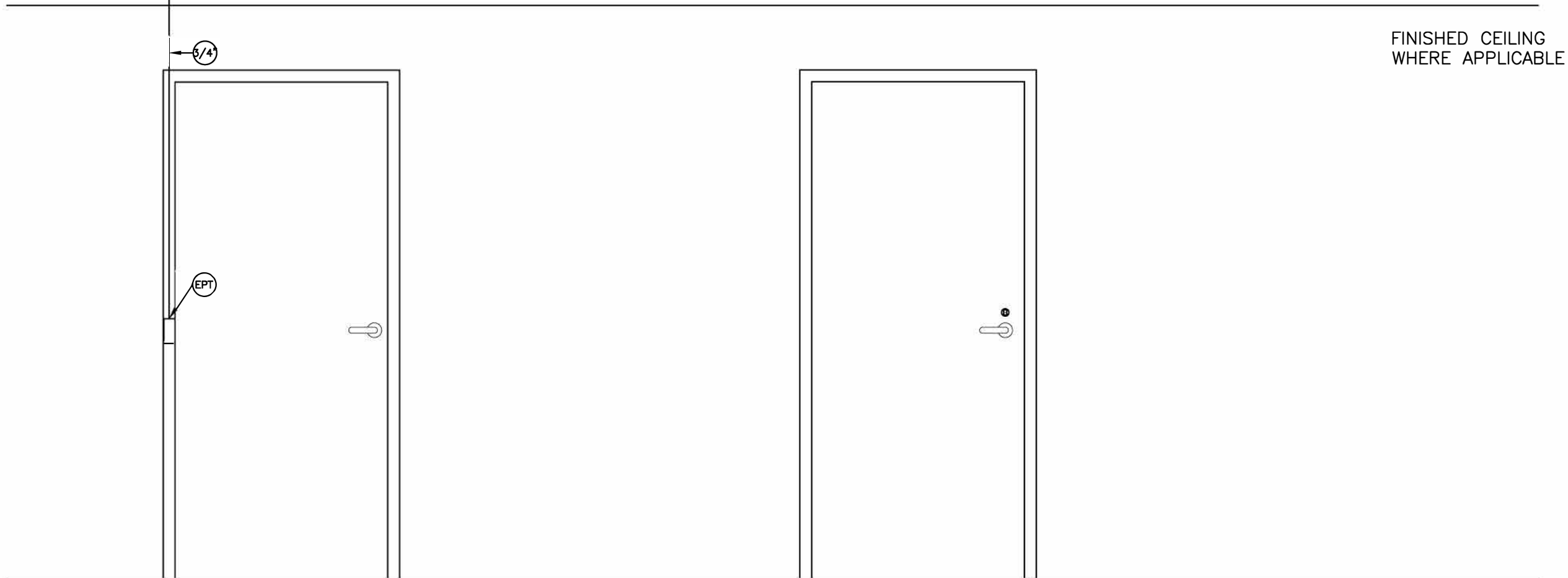

FINISHED CEILING  
 WHERE APPLICABLE

INTERIOR SIDE

EXTERIOR SIDE

FINISHED FLOOR

Date: 20230301

Dwg. No.: SH-06.00

ELEVATION VIEW: ELECTRIFIED MORTISE LOCK SET - EXIT ONLY DETAIL

AUBURN UNIVERSITY - DESIGN AND CONSTRUCTION STANDARDS

SH  
 06.00

ELEVATION VIEW: ELECTRIFIED MORTISE LOCK SET - EXIT ONLY DETAIL

NOT TO SCALE

2025 Door Hardware Standards

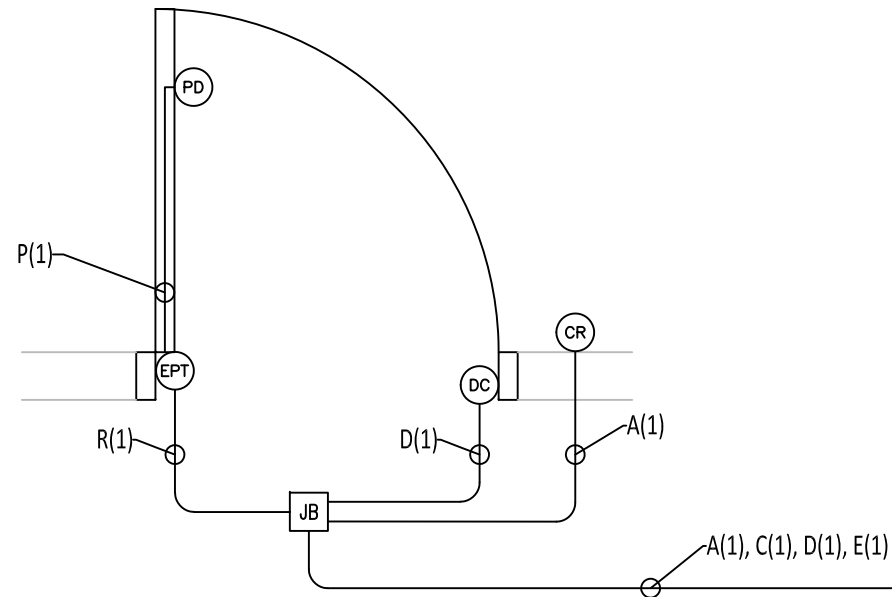

CABLE LEGEND		
A	24ga. 1pr. SHIELDED + 18ga. 2c UNSHIELDED OSDP CMP	K
B	24ga. 2c SHIELDED 120 Ohm OSDP CMP	L
C	22ga. 4c UNSHIELDED	M
D	22ga. 2c UNSHIELDED CMR	N
E	18ga. 2c UNSHIELDED	P QUICK CONNECT HARNESS <sup>(1)</sup>
F		R QUICK CONNECT HARNESS <sup>(1)</sup>
G		S
H		T
J		

All manufactures recommendations for cable wire gauge per run length shall be followed, no exceptions.  
 (1) See Hardware Schedule for Harness part number.

- QTY. SECURITY MATERIALS  
 1 CREDENTIAL READER - CR  
 1 DOOR CONTACT - DC  
 1 RIM PANIC DEVICE w/ RQE and ELECTRIFIED LEVER TRIM- PD  
 1 PANIC DEVICE POWER SUPPLY - PDPS  
 1 ELECTRIC POWER TRANSFER - EPT

\*SEE HARDWARE SCHEDULE FOR FULL PRODUCT DETAILS AND PART NUMBERS. \*

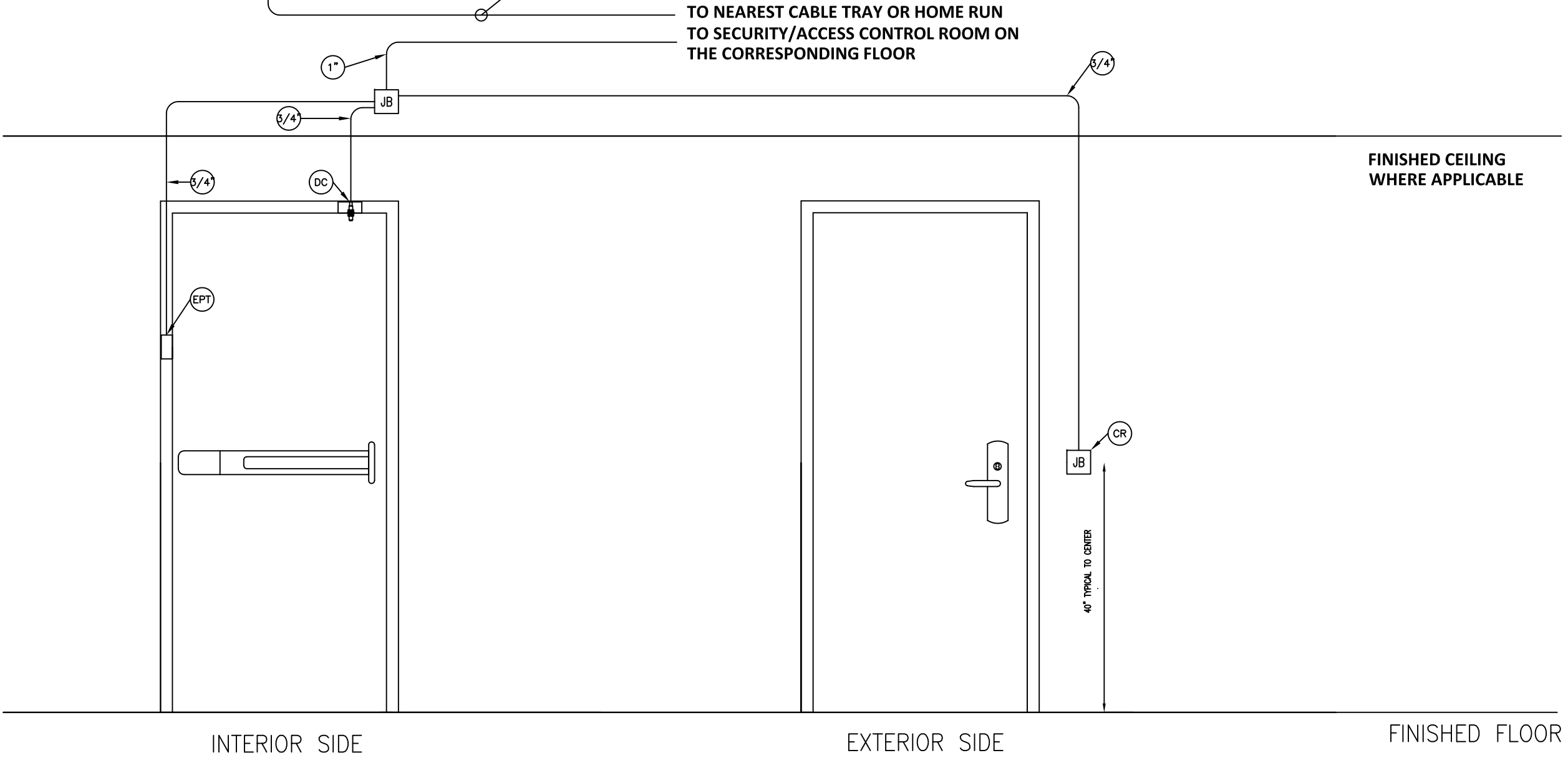

Revision Date: 20230301  
 Dwg. No.: SH-07.00

ELEVATION VIEW: STAIRWELL ELECTRIFIED PANIC DEVICE - WITH READER DETAIL

AUBURN UNIVERSITY - DESIGN AND CONSTRUCTION STANDARDS

SH  
 07.00

ELEVATION VIEW: STAIRWELL ELECTRIFIED PANIC DEVICE - WITH READER DETAIL  
 NOT TO SCALE

2025 Door Hardware Standards

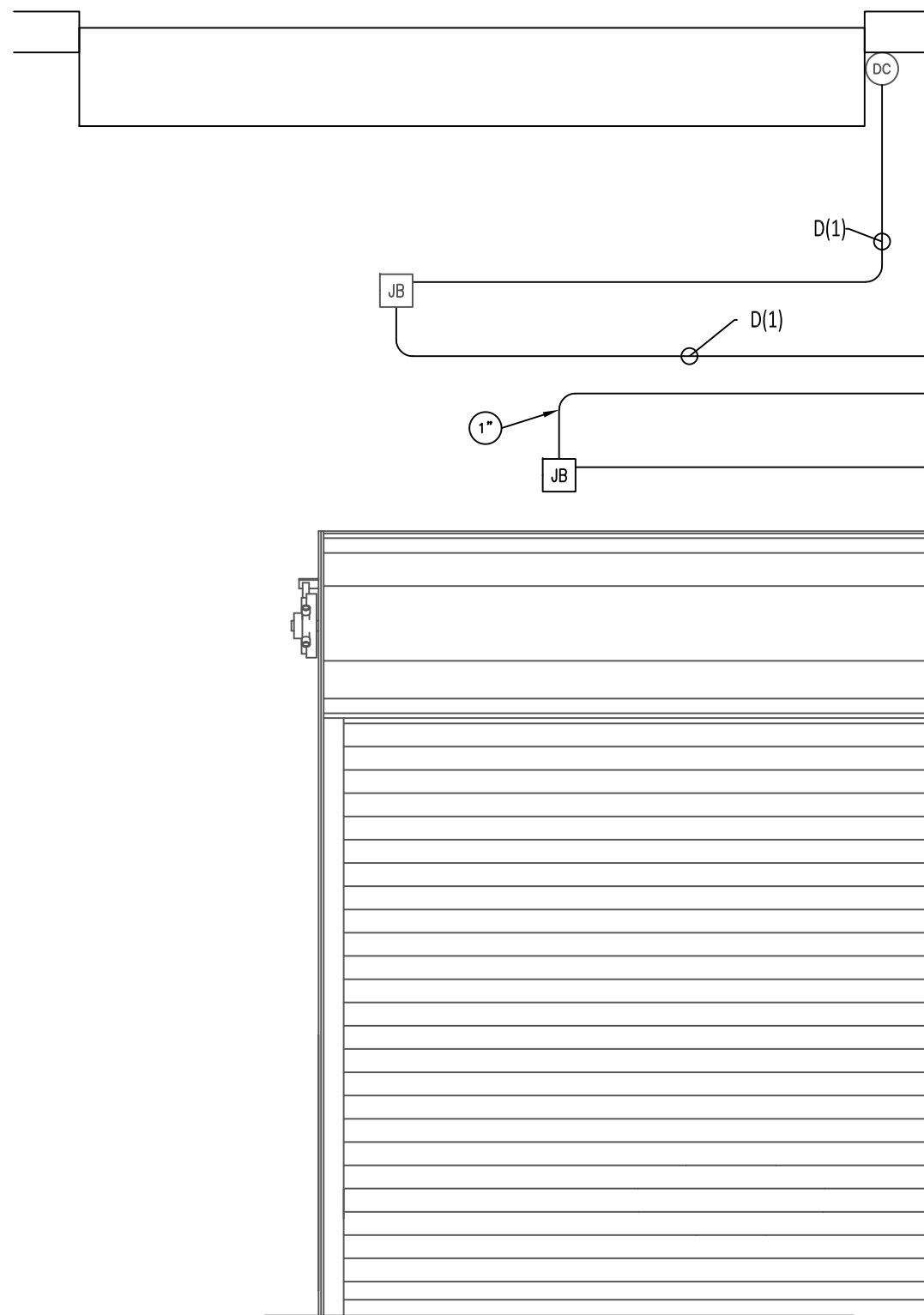

CABLE LEGEND		
A	24ga. 1pr. SHIELDED + 18ga. 2c UNSHIELDED OSDP CMP	K
B	24ga. 2c SHIELDED 120 Ohm OSDP CMP	L
C	22ga. 4c UNSHIELDED	M
D	22ga. 2c UNSHIELDED CMR	N
E	18ga. 2c UNSHIELDED	P QUICK CONNECT HARNESS <sup>(1)</sup>
F		R QUICK CONNECT HARNESS <sup>(1)</sup>
G		S
H		T
J		

All manufactures recommendations for cable wire gauge per run length shall be followed, no exceptions.  
 (1) See Hardware Schedule for Harness part number.

TO NEAREST CABLE TRAY OR HOME RUN  
 TO SECURITY/ACCESS CONTROL ROOM ON  
 THE CORRESPONDING FLOOR

QTY. SECURITY MATERIALS  
 1 DOOR CONTACT - DC

\*SEE HARDWARE SCHEDULE FOR FULL PRODUCT DETAILS AND PART NUMBERS. \*

(1) See hardware schedule for part number.

Revision Date: 20220909  
 Dwg. No.: SH-08.00

ELEVATION VIEW: OVER HEAD COILING DOOR - MONITORED

AUBURN UNIVERSITY - DESIGN AND CONSTRUCTION STANDARDS

SH  
 08.00

ELEVATION VIEW: OVER HEAD COILING DOOR - MONITORED  
 NOT TO SCALE

2025 Door Hardware Standards

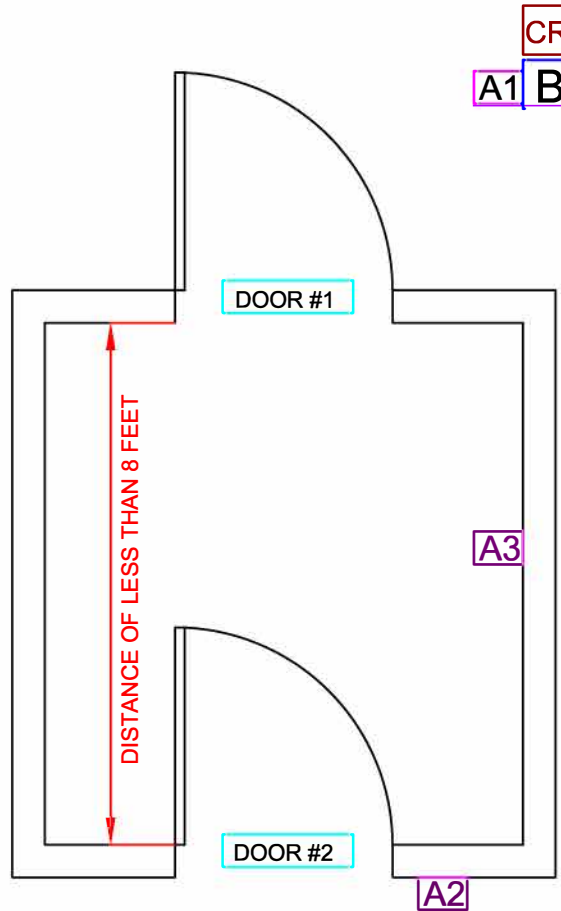

**Operational Configuration**

\* Note Door #2 is push/pull and can never be locked.\*

Daytime operation, door is set in the unlocked status

- Actuator A1 will open Door #1 and Door #2.
- Actuator A2 will open Door #1 and Door #2.
- Actuator A3 will open Door #1 and Door #2.

After-hours operation, door is set in the card only (Locked) status.

- Actuator A2 will unlock and open Door #1 and Door #2.
- Actuator A3 will unlock and open Door #1 and Door #2.
- Valid credential presented at reader CR will unlock Door #1 at which time Actuator A1 can be used to open Door #1 and Door #2.

# Striket4

SP2000  
Power Supply

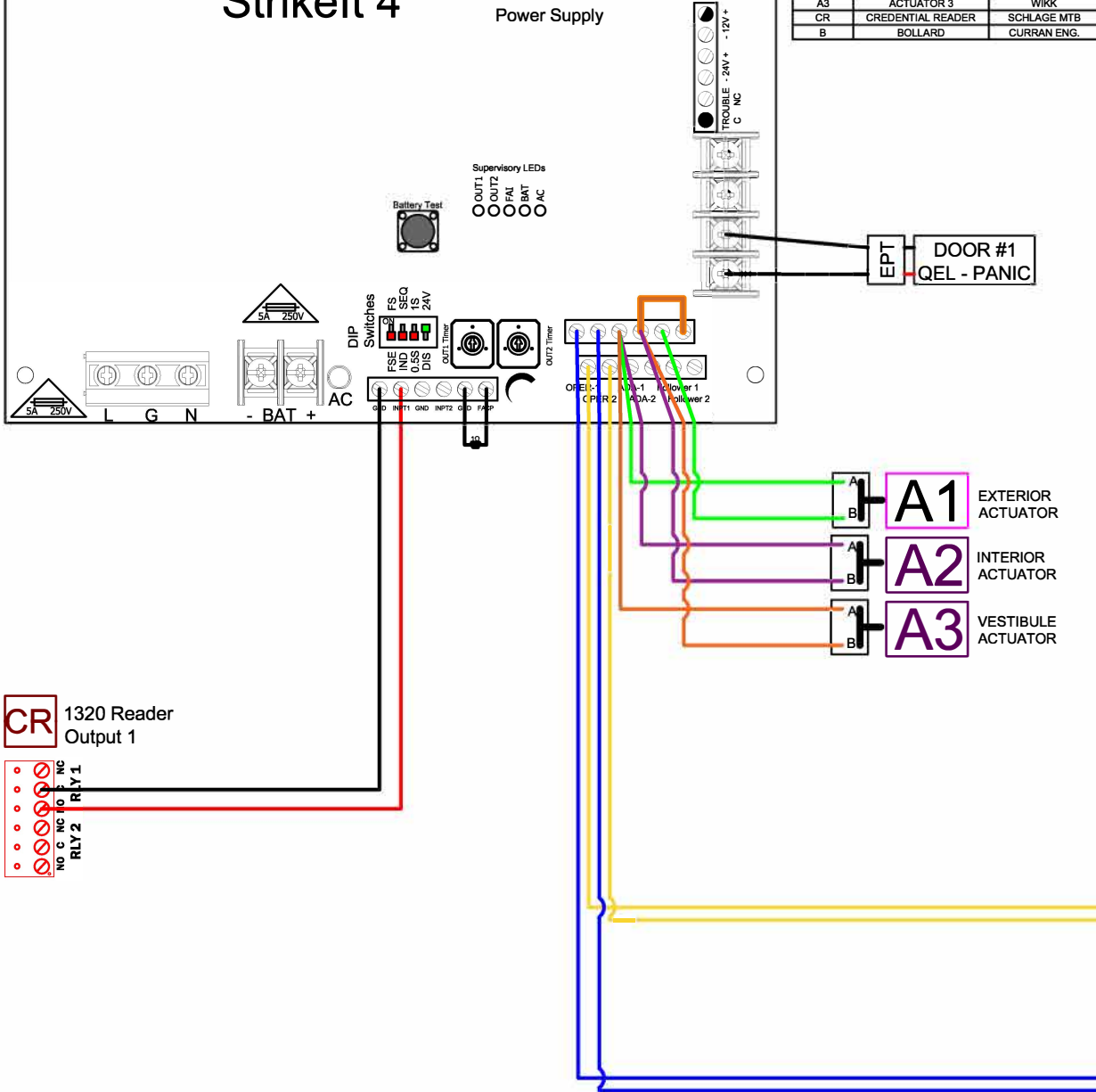

LEGEND		
DOOR #1	ADA OPERATOR	LCN
A1	ACTUATOR 1	WIKK
A2	ACTUATOR 2	WIKK
A3	ACTUATOR 3	WIKK
CR	CREDENTIAL READER	SCHLAGE MTB
B	BOLLARD	CURRAN ENG.

WIRING POINT TO POINT		
1320		
1320 - Output Relay 1C	Striket4 - INP 1	
1320 - Output Relay 1NO	Striket4 - INP 1 GND	
Activated with Unlock Command	Adjust Strike Time to 5	
STRIKEIT4		
24V - +	not used	Aux Power
12V - +	not used	Aux Power
BAT - +	not used	Aux Power
OUT 1 +	DOOR #1 QEL +	First Exit Device
OUT 1 -	DOOR #1 QEL -	First Exit Device
OUT 2 +	not used	Second Exit Device
OUT 2 -	not used	Second Exit Device
FACP/GND	1 Ohm Resistor if not used	Fire Alarm Interface
INP 1	1320 RLY1 - NO	Reader Output - Normally Open
INP 1 GND	1320 RLY1 - C	Reader Output - Common
INP 2	not used	
INP 2 GND	not used	
OPER 1A	Door #1 Exterior ADA Operator Trigger A	
OPER 1B	Door #1 Exterior ADA Operator Trigger B	
OPER 2A	Door #2 Interior ADA Operator Trigger A	
OPER 2B	Door #2 Interior ADA Operator Trigger B	
ADA 1A	A1 EXT Act A, A2 INT Act A, & A3 VEST Act A	3 Wires
ADA 1B	A2 INT Act B, A3 VEST Act B, & Jumper to Follower 1B	3 Wires
ADA 2A	not used	
ADA 2B	not used	
FOLLOWER 1A	A1 Exterior Act B	Follows OUT 1
FOLLOWER 1B	Jumper to ADA 1B	Follows OUT 1
FOLLOWER 2A	not used	
FOLLOWER 2B	not used	
Dip Switch 1 - OFF	Fail Secure	
Dip Switch 2 - OFF	Independent/Sequential Operation	ON - OUT 2 follows IN 1
Dip Switch 3 - OFF	0.5 Seconds	Duration of Operation Pulse
Dip Switch 4 - ON	OUT 1 & 2 Energized with FA	
OUT 1 Timer	Set to Almost Full Counterclockwise	Adjusts Output Activation Time
OUT 2 Timer	Set to Full Counterclockwise	Adjusts Output Activation Time
EXTERIOR ADA ACTUATOR - A1		
OUTPUT A	ADA 1A	
OUTPUT B	FOLLOWER 1A	
INTERIOR ADA ACTUATOR - A2		
OUTPUT A	ADA 1A	
OUTPUT B	ADA 1B	
VESTIBULE EXTERIOR ADA ACTUATOR - A3		
OUTPUT A	ADA 1A	
OUTPUT B	ADA 1B	
DOOR #1 - ADA OPERATOR		
STRIKEIT4 - OPER 1A	LCN TERMINAL 16	
STRIKEIT4 - OPER 1B	LCN TERMINAL 17	
DOOR #2 - ADA OPERATOR		
STRIKEIT4 - OPER 2A	LCN TERMINAL 16	
STRIKEIT4 - OPER 2B	LCN TERMINAL 17	

## DOOR #2 AUTO OPERATOR - INTERIOR

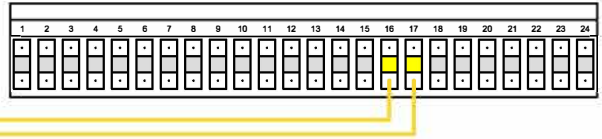

## DOOR #1 AUTO OPERATOR - EXTERIOR

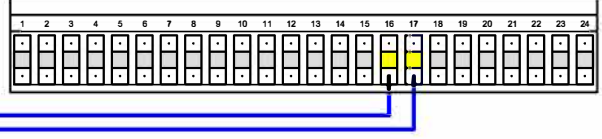

ADA  
01.12

# STANDARD ADA ACCESS POINT WIRING CONFIGURATION - LESS THAN 8 FEET

NOT TO SCALE

Approved by the Auburn University Office of Accessibility

REV:20231001

2025 Door Hardware Standards

Date: October, 1 2023

Dwg. No.: AUADA-01.12

STANDARD ADA ACCESS POINT WIRING CONFIGURATION - LESS THAN 8 FEET

AUBURN UNIVERSITY - DESIGN AND CONSTRUCTION STANDARDS

LEGEND		
DOOR #1	ADA OPERATOR	LCN
A1	ACTUATOR 1	WIKK
A2	ACTUATOR 2	WIKK
A3	ACTUATOR 3	WIKK
A4	ACTUATOR 4	WIKK
CR	CREDENTIAL READER	SCHLAGE MTB
B	BOLLARD	CURRAN ENG.

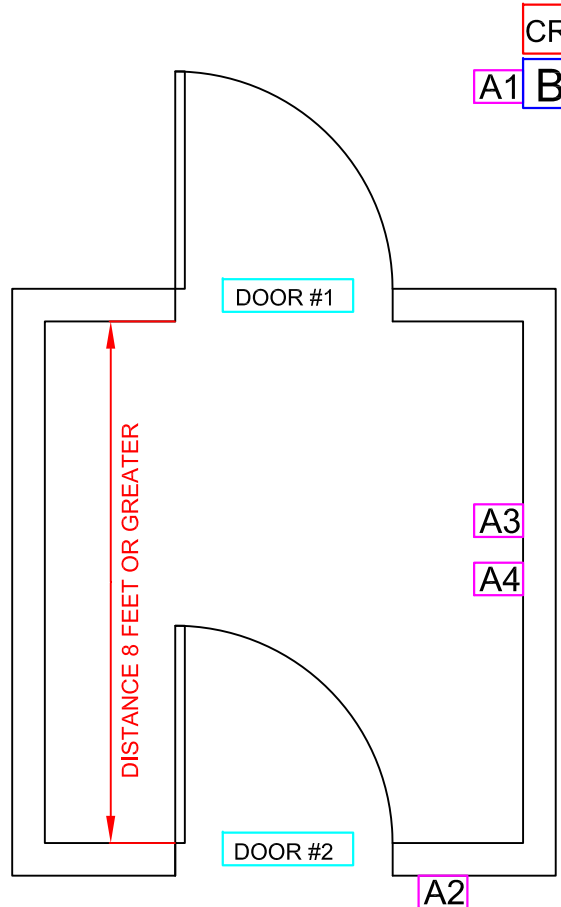

**Operational Configuration**

\*Note Door #2 is push/pull and can never be locked.\*

Daytime operation, door is set in the unlocked status

- Actuator A1 will open Door #1.
- Actuator A2 will open Door #2.
- Actuator A3 will open Door #1.
- Actuator A4 will open Door #2.

After-hours operation, door is set in the card only (Locked) status.

- Actuator A2 will open Door #2.
- Actuator A3 will unlock and open Door #1.
- Actuator A4 will open Door #2.
- Valid credential presented at reader CR will unlock Door #1 at which time Actuator A1 can be used to open Door #1.

# Striket4

SP2000  
Power Supply

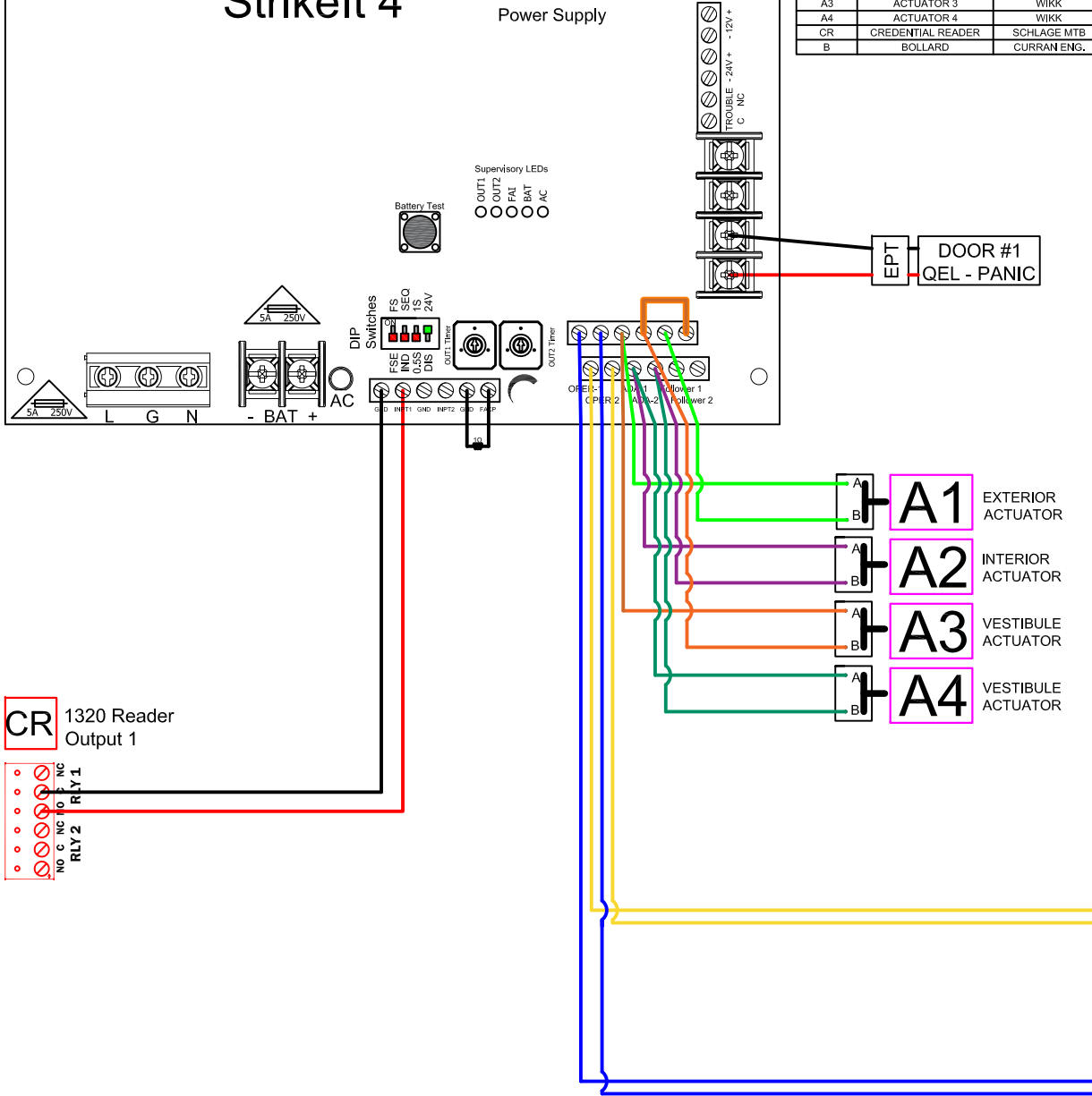

LEGEND		
DOOR #1	ADA OPERATOR	LCN
A1	ACTUATOR 1	WIKK
A2	ACTUATOR 2	WIKK
A3	ACTUATOR 3	WIKK
A4	ACTUATOR 4	WIKK
CR	CREDENTIAL READER	SCHLAGE MTB
B	BOLLARD	CURRAN ENG.

WIRING POINT TO POINT		
1320		
1320 - Output Relay 1C	Striket4 - INP 1	
1320 - Output Relay 1NO	Striket4 - INP 1 GND	
Activated with Unlock Command	Adjust Strike Time to 5	
STRIKEIT4		
24V - +	not used	Aux Power
12V - +	not used	Aux Power
BAT - +	not used	Aux Power
OUT 1 +	DOOR #1 QEL +	First Exit Device
OUT 1 -	DOOR #1 QEL -	First Exit Device
OUT 2 +	not used	Second Exit Device
OUT 2 -	not used	Second Exit Device
FACP/GND	1 Ohm Resistor if not used	Fire Alarm Interface
INP 1	1320 RLY1 - NO	Reader Output - Normally Open
INP 1 GND	1320 RLY1 - C	Reader Output - Common
INP 2	not used	
INP 2 GND	not used	
OPER 1A	Door #1 Exterior ADA Operator Trigger A	
OPER 1B	Door #1 Exterior ADA Operator Trigger B	
OPER 2A	Door #2 Interior ADA Operator Trigger A	
OPER 2B	Door #2 Interior ADA Operator Trigger B	
ADA 1A	A1 EXT Act A, & A3 VEST Act A	2 Wires
ADA 1B	A3 VEST Act B, & Jumper to Follower 1B	2 Wires
ADA 2A	Vestibule Actuator A and Act A	2 wires
ADA 2B	A2 Interior Act B & A4 Vest Act B	2 wires
FOLLOWER 1A	A1 Exterior Act B	Follows OUT 1
FOLLOWER 1B	Jumper to ADA 1B	Follows OUT 1
FOLLOWER 2A	not used	
FOLLOWER 2B	not used	
Dip Switch 1 - OFF	Fail Secure	
Dip Switch 2 - OFF	Independent/Sequential Operation	ON - OUT 2 follows IN 1
Dip Switch 3 - OFF	0.5 Seconds	Duration of Operation Pulse
Dip Switch 4 - ON	OUT 1 & 2 Energized with FA	
OUT1 Timer	Set to Almost Full Counterclockwise	Adjusts Output Activation Time
OUT2 Timer	Set to Full Counterclockwise	Adjusts Output Activation Time
EXTERIOR ADA ACTUATOR - A1		
OUTPUT A	ADA 1A	
OUTPUT B	FOLLOWER 1A	
INTERIOR ADA ACTUATOR - A2		
OUTPUT A	ADA 2A	
OUTPUT B	ADA 2B	
VESTIBULE EXTERIOR ADA ACTUATOR - A3		
OUTPUT A	ADA 1A	
OUTPUT B	ADA 1B	
VESTIBULE INTERIOR ADA ACTUATOR - A4		
OUTPUT A	ADA 2A	
OUTPUT B	ADA 2B	
DOOR #1 - ADA OPERATOR		
STRIKEIT4 - OPER 1A	LCN TERMINAL 16	
STRIKEIT4 - OPER 1B	LCN TERMINAL 17	
DOOR #2 - ADA OPERATOR		
STRIKEIT4 - OPER 2A	LCN TERMINAL 16	
STRIKEIT4 - OPER 2B	LCN TERMINAL 17	

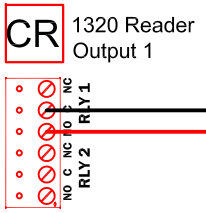

## DOOR #2 AUTO OPERATOR - INTERIOR

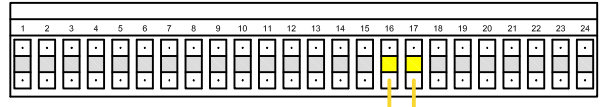

## DOOR #1 AUTO OPERATOR - EXTERIOR

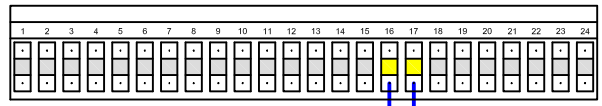

Date: October, 1 2023  
Dwg. No.: ADA-01.22

STANDARD ADA ACCESS POINT WIRING CONFIGURATION - GREATER THAN 8 FOOT  
AUBURN UNIVERSITY - DESIGN AND CONSTRUCTION STANDARDS

ADA  
01.22

# STANDARD ADA ACCESS POINT WIRING CONFIGURATION - 8 FEET OR GREATER

NOT TO SCALE

Approved by the Auburn University Office of Accessibility

REV:20231001

2025 Door Hardware Standards

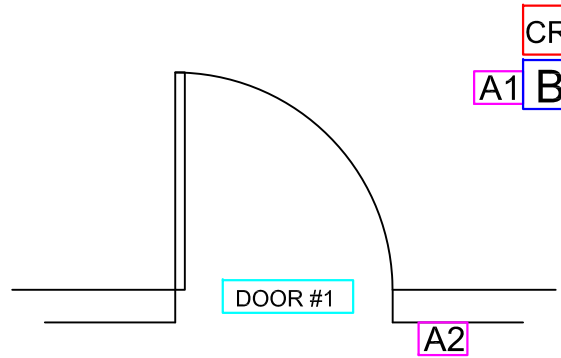

Theory of Operation

\* Note: Secure ADA Access Point Not at a Vestibule.\*

- Reader Card Only: Exterior Actuator inactive. Interior Actuator unlocks door and activates operator.
- Access Granted: Exterior Actuator active.
- Reader Unlocked: Exterior Actuator active. Interior Actuator active.

# Strikelt 4

SP2000  
Power Supply

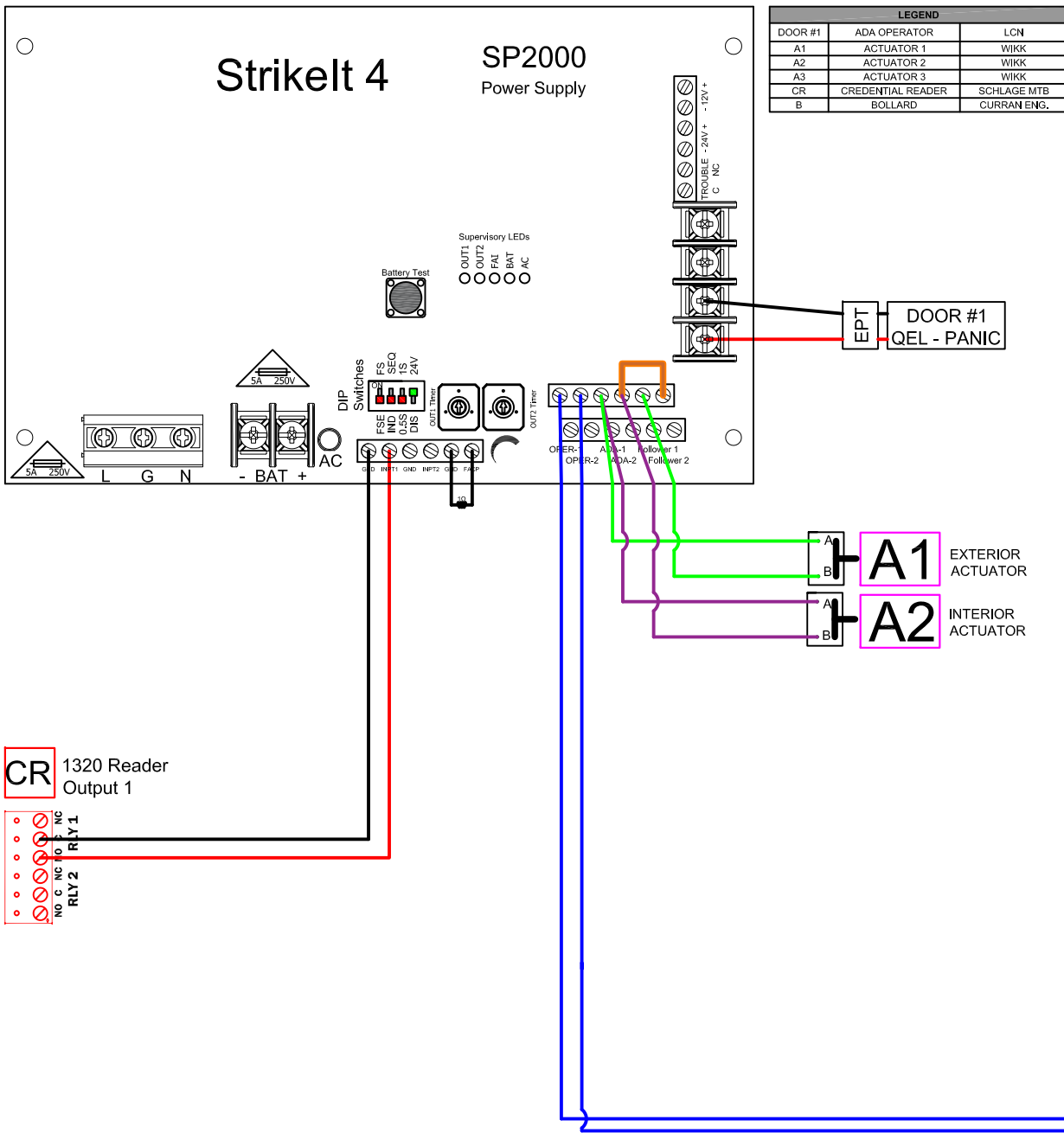

LEGEND		
DOOR #1	ADA OPERATOR	LCN
A1	ACTUATOR 1	WIKK
A2	ACTUATOR 2	WIKK
A3	ACTUATOR 3	WIKK
CR	CREDENTIAL READER	SCHLAGE MTB
B	BOLLARD	CURRAN ENG.

WIRING POINT TO POINT		
1320		
1320 - Output Relay 1C	Strikelt4 - INP 1	
1320 - Output Relay 1NO	Strikelt4 - INP 1 GND	
Activated with Unlock Command		
Adjust Strike Time to 5		
STRIKEIT4		
24V - +	not used	Aux Power
12V - +	not used	Aux Power
BAT - +	not used	Aux Power
OUT 1 +	DOOR #1 QEL +	First Exit Device
OUT 1 -	DOOR #1 QEL -	First Exit Device
OUT 2 +	not used	Second Exit Device
OUT 2 -	not used	Second Exit Device
FACP/GND	1 Ohm Resistor if not used	Fire Alarm Interface
INP 1	1320 RLY1 - NO	Reader Output - Normally Open
INP 1 GND	1320 RLY1 - C	Reader Output - Common
INP 2	not used	
INP 2 GND	not used	
OPER 1A	Door #1 Exterior ADA Operator Trigger A	
OPER 1B	Door #1 Exterior ADA Operator Trigger B	
OPER 2A	not used	
OPER 2B	not used	
ADA 1A	A1 EXT Act A, & A2 INT Act A	2 Wires
ADA 1B	A2 INT Act B, & Jumper to Follower 1B	2 Wires
ADA 2A	not used	
ADA 2B	not used	
FOLLOWER 1A	A1 Exterior Act B	Follows OUT 1
FOLLOWER 1B	Jumper to ADA 1B	Follows OUT 1
FOLLOWER 2A	not used	
FOLLOWER 2B	not used	
Dip Switch 1 - OFF	Fail Secure	
Dip Switch 2 - OFF	Independent/Sequential Operation	ON - OUT 2 follows IN 1
Dip Switch 3 - OFF	0.5 Seconds	Duration of Operation Pulse
Dip Switch 4 - ON	OUT 1 & 2 Energized with FA	
OUT1 Timer	Set to Almost Full Counterclockwise	Adjusts Output Activation Time
OUT2 Timer	Set to Full Counterclockwise	Adjusts Output Activation Time
EXTERIOR ADA ACTUATOR - A1		
OUTPUT A	ADA 1A	
OUTPUT B	FOLLOWER 1A	
INTERIOR ADA ACTUATOR - A2		
OUTPUT A	ADA 1A	
OUTPUT B	ADA 1B	
DOOR #1 - ADA OPERATOR		
STRIKEIT4 - OPER 1A	LCN TERMINAL 16	
STRIKEIT4 - OPER 1B	LCN TERMINAL 17	

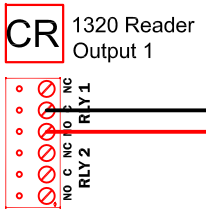

## DOOR #1 AUTO OPERATOR - EXTERIOR

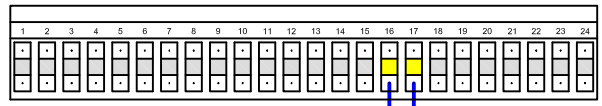

Date: October 1, 2023  
Dwg. No.: AUADA-02.12

### STANDARD SINGLE ADA ACCESS POINT WIRING CONFIGURATION

AUBURN UNIVERSITY - DESIGN AND CONSTRUCTION STANDARDS

ADA  
02.12

## STANDARD SINGLE ADA ACCESS POINT WIRING CONFIGURATION

NOT TO SCALE

Approved by the Auburn University Office of Accessibility

REV:20231001

2025 Door Hardware Standards

Hardware S

LEGEND		
DOOR #1	ADA OPERATOR	LCN - 4642
A1	ACTUATOR 1	WIKK
A2	ACTUATOR 2	WIKK
B	ADA BOLLARD	CURRAN

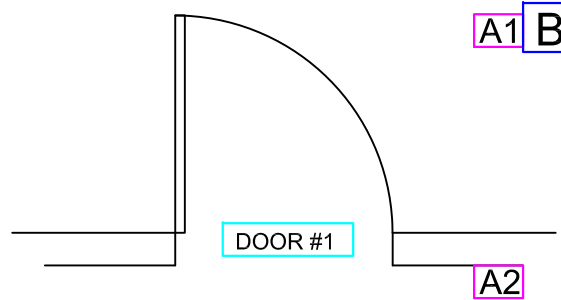

**Operational Configuration**

\* Note: Non-Secure ADA Access Point \*  
 Pull-Side Actuator must be mounted to meet minimum clearance required.

24/7 Operation, door is not lockable. No Locking Hardware.

- Actuator A1 will open Door #1.
- Actuator A2 will open Door #1.

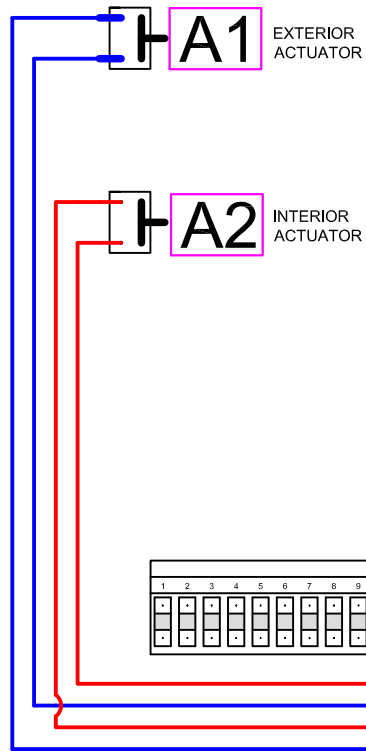

LEGEND		
DOOR #1	ADA OPERATOR	LCN
A1	ACTUATOR 1	WIKK
A2	ACTUATOR 2	WIKK

**Operational Configuration**

\* Note: Non-Secure ADA Access Point \*  
 Pull-Side Actuator must be mounted to meet minimum clearance required.

Date: October 1, 2023

Dwg. No.: AUADA-03.12

STANDARD SINGLE ADA ACCESS POINT WIRING CONFIGURATION NONLOCKING

AUBURN UNIVERSITY - DESIGN AND CONSTRUCTION STANDARDS

ADA  
03.12

STANDARD SINGLE ADA ACCESS POINT WIRING CONFIGURATION NONLOCKING

NOT TO SCALE

Approved by the Auburn University Office of Accessibility

REV:20231001

2025 Door Hardware Standards

### **Preferred Cable & Color Scheme**

- **RS-485 (Downstream Communication) Orange**  
**Manufacture:** West Penn Wire  
**Part:** WPN1PR24POR  
**Description:** 1 Pair 24AWG Shielded 120 Ohm OSDP CMP
  
- **RS-485/Power (Reader) Orange**  
**Manufacture:** West Penn Wire  
WPN1PR2418P0R  
1 Pair 24AWG Shielded + 18/2 UNSHLD OSDP CMP
  
- **Lock Power White**  
**Manufacture:** West Penn Wire  
WPN25224BGY  
1P 18G STRD UNSHLD PLENII
  
- **Strike Output White**  
**Manufacture:** West Penn Wire  
221WH  
22/2 Unshielded CMR
  
- **DPS/REQ Blue**  
**Manufacture:** West Penn Wire  
25241BLB  
4C 22G STRD UNSHLD PLENII

### **Cable Run Lengths**

- **Schlage MTB11/MTB15**  
Up to 700'
  
- **Von Duprin QEL Panic Device (Power Only)**  
Up to 200' – 18AWG  
Up to 320' – 16AWG  
Up to 500' – 14AWG  
Up to 800' – 12AWG
  
- **BEST 45HW Wired Mortise Lockset (Power Only)**  
Up to 250' – 18AWG  
Up to 400' – 16AWG  
Up to 600' – 14AWG

**Document Revision History**

Version	Section	Summary of Change	Date